

ELECTRICIAN

NSQF (LEVEL - 5)

3rd Semester

TRADE PRACTICAL

SECTOR: Electrical



Directorate General of Training

**DIRECTORATE GENERAL OF TRAINING
MINISTRY OF SKILL DEVELOPMENT & ENTREPRENEURSHIP
GOVERNMENT OF INDIA**



**NATIONAL INSTRUCTIONAL
MEDIA INSTITUTE, CHENNAI**

Post Box No. 3142, CTI Campus, Guindy, Chennai - 600 032

Sector : Electrical

Duration : 2 - Years

Trade : Electrician 3rd Semester - Trade Practical - NSQF (LEVEL - 5)

Copyright© 2018 National Instructional Media Institute, Chennai

First Edition : October 2018, Copies : 1,000

First Reprint : December 2018, Copies : 5,000

Rs.190/-

All rights reserved.

No part of this publication can be reproduced or transmitted in any form or by any means, electronic or mechanical, including photocopy, recording or any information storage and retrieval system, without permission in writing from the National Instructional Media Institute, Chennai.

Published by:

NATIONAL INSTRUCTIONAL MEDIA INSTITUTE
P. B. No.3142, CTI Campus, Guindy Industrial Estate,
Guindy, Chennai - 600 032.
Phone : 044 - 2250 0248, 2250 0657, 2250 2421
Fax : 91 - 44 - 2250 0791
email : nimi_bsnl@dataone.in
chennai-nimi@nic.in
Website: www.nimi.gov.in

FOREWORD

The Government of India has set an ambitious target of imparting skills to 30 crores people, one out of every four Indians, by 2020 to help them secure jobs as part of the National Skills Development Policy. Industrial Training Institutes (ITIs) play a vital role in this process especially in terms of providing skilled manpower. Keeping this in mind, and for providing the current industry relevant skill training to Trainees, ITI syllabus has been recently updated with the help of Mentor Councils comprising of various stakeholder's viz. Industries, Entrepreneurs, Academicians and representatives from ITIs.

National Instructional Media Institute (NIMI), Chennai has come up with instructional material to suit the revised curriculum for **Electrician 3rd Semester Trade Practical NSQF (LEVEL - 5)** in **Electrical** sector under Semester Pattern required for ITIs and related institutions imparting skill development. The NSQF (LEVEL- 5) will help the trainees to get an international equivalency standard where their skill proficiency and competency will be duly recognized across the globe and this will also increase the scope of recognition of prior learning. NSQF (LEVEL - 5) trainees will also get the opportunities to promote life long learning and skill development. I have no doubt that with NSQF (LEVEL - 5) the trainers and trainees of ITIs, and all stakeholders will derive maximum benefits from these IMPs and that NIMI's effort will go a long way in improving the quality of Vocational training in the country.

The Executive Director & Staff of NIMI and members of Media Development Committee deserve appreciation for their contribution in bringing out this publication.

Jai Hind

RAJESH AGGARWAL

Director General / Addl. Secretary,
Ministry of Skill Development & Entrepreneurship,
Government of India.

New Delhi - 110 001

PREFACE

The National Instructional Media Institute (NIMI) was established in 1986 at Chennai by then Directorate General of Employment and Training (D.G.E & T), Ministry of Labour and Employment, (now under Ministry of Skill Development and Entrepreneurship) Government of India, with technical assistance from the Govt. of the Federal Republic of Germany. The prime objective of this institute is to develop and provide instructional materials for various trades as per the prescribed syllabi (NSQF) under the Craftsman and Apprenticeship Training Schemes.

The instructional materials are created keeping in mind, the main objective of Vocational Training under NCVT/NAC in India, which is to help an individual to master skills to do a job. The instructional materials are generated in the form of Instructional Media Packages (IMPs). An IMP consists of Theory book, Practical book, Test and Assignment book, Instructor Guide, Audio Visual Aid (Wall charts and Transparencies) and other support materials.

The trade practical book consists of series of exercises to be completed by the trainees in the workshop. These exercises are designed to ensure that all the skills in the prescribed syllabus are covered. The trade theory book provides related theoretical knowledge required to enable the trainee to do a job. The test and assignments will enable the instructor to give assignments for the evaluation of the performance of a trainee. The wall charts and transparencies are unique, as they not only help the instructor to effectively present a topic but also help him to assess the trainee's understanding. The instructor guide enables the instructor to plan his schedule of instruction, plan the raw material requirements, day to day lessons and demonstrations.

IMPs also deals with the complex skills required to be developed for effective team work. Necessary care has also been taken to include important skill areas of allied trades as prescribed in the syllabus.

The availability of a complete Instructional Media Package in an institute helps both the trainer and management to impart effective training.

The IMPs are the outcome of collective efforts of the staff members of NIMI and the members of the Media Development Committees specially drawn from Public and Private sector industries, various training institutes under the Directorate General of Training (DGT), Government and Private ITIs.

NIMI would like to take this opportunity to convey sincere thanks to the Directors of Employment & Training of various State Governments, Training Departments of Industries both in the Public and Private sectors, Officers of DGT and DGT field institutes, proof readers, individual media developers and coordinators, but for whose active support NIMI would not have been able to bring out this materials.

Chennai - 600 032

R. P. DHINGRA
EXECUTIVE DIRECTOR

ACKNOWLEDGEMENT

National Instructional Media Institute (NIMI) sincerely acknowledges with thanks for the co-operation and contribution extended by the following Media Developers and their sponsoring organisations to bring out this Instructional Material (**Trade Practical**) for the trade of **Electrician NSQF (LEVEL - 5)** under **Electrical Sector** for ITIs.

MEDIA DEVELOPMENT COMMITTEE MEMBERS

- | | |
|-------------------------|--|
| Shri. D.S. Varadarajulu | - DD/Principal, (Retd.),
Govt. I.T.I, Ambattur,
Chennai - 98. |
| Shri. G.Ethirajulu | - Principal (Retd.),
Govt. I.T.I, Guindy,
Chennai - 32. |
| Shri. M.H. Nagesh | - Junior Training Officer
Govt. I.T.I,
Mysuru - 570 007. |
| Smt. S.Chandrakala | - Junior Training Officer
Govt. I.T.I,
Mysuru - 570 007. |
| Smt. D.Vinutha | - Junior Training Officer
Govt. I.T.I,
Bangalore - 560 029. |
| Shri P. Natarajan | - Assistant Training Officer
Govt. ITI, Anaikatti,
Coimbatore (Dist) |
| Shri K. Mohandass | - Assistant Training Officer
Govt. ITI, North Chennai
Chennai - 21. |

NIMICO-ORDINATORS

- | | |
|-------------------------|---|
| Shri. K. Srinivasa Rao | - Joint Director
NIMI, Chennai - 32. |
| Shri. Subhankar Bhowmik | - Assistant Manager,
NIMI, Chennai - 32. |

NIMI records its appreciation for the Data Entry, CAD, DTP operators for their excellent and devoted services in the process of development of this Instructional Material.

NIMI also acknowledges with thanks the invaluable efforts rendered by all other NIMI staff who have contributed towards the development of this Instructional Material.

NIMI is also grateful to everyone who has directly or indirectly helped in developing this Instructional Material.

INTRODUCTION

This manual for trade practical is intended for use in the ITI workshop. It consists of a series of practical exercises that are to be completed by the trainees during the first semester of course is the **Electrician trade under Electrical Sector. It is National Skills Qualifications Framework NSQF (LEVEL- 5)**, supplemented and supported by instructions/information to assist the trainees in performing the exercise. The exercises are designed to ensure that all the skills prescribed in the syllabus are covered including the allied trades. The syllabus for the 3rd Semester **Electrician Trade under Electrical Sector Trade Practical** is divided into Six Modules. The allocation of time for the various modules is given below:

Module 1 - DC Generator	7 Exercises	78 Hrs
Module 2 - DC Motor	9 Exercises	122 Hrs
Module 3 - AC Three Phase Motor	11 Exercises	125 Hrs
Module 4 - AC Single Phase Motor	9 Exercises	100 Hrs
Module 5 - Alternator	5 Exercises	50 Hrs
Module 6 - Synchronous Motor and MG Set	4 Exercises	50 Hrs
Total	45 Exercises	525 Hrs

The syllabus and the content in the modules are interlinked. As the number of workstations available in the electrical section is limited by the machinery and equipment, it is necessary to interpolate the exercises in the modules to form a proper teaching and learning sequence. The sequence of instruction is given in the schedule of instruction which is incorporated in the Instructor's Guide. With 25 practical hours a week of 5 working days 100 hours of practical per month is available.

Contents of Trade Practical

The procedure for working through the 45 exercises for the 3rd semester with the specific objectives as the learning out comes at the end of each exercise is given in this book.

The skill objectives and tools/instruments, equipment/machines and materials required to perform the exercise are given in the beginning of each exercise. Skill training in the shop floor is planned through a series of practical exercises/experiments to support the related theory to make the trainees get hands on training in the Electrician trade along with the relevant cognitive skills appropriate for the level. A minimum number of projects have been included to make the training more effective and develop attitude to work in a team. Pictorial, schematic, wiring and circuit diagrams have been included in the exercises, wherever necessary, to assist the trainees broaden their views. The symbols used in the diagrams comply with the Bureau of Indian Standards (BIS) specifications.

Illustrations in this manual, help trainees visual perspective of the ideas and concepts. The procedures to be followed for completing the exercises is also given. Different forms of intermediate test questions have been included in the exercises, to enhance the trainee to trainee and trainee to instructor interactions.

Skill Information

Skill areas which are repetitive in nature are given as separate skill information sheets. Skills which are to be developed in specific areas are included in the exercises itself. Some subexercises are developed to fulfill the sequence of exercises in keeping with the syllabus.

This manual on trade practical forms part of the Written Instructional Material (WIM). Which includes manual on trade theory and assignment/test.

CONTENTS

Exercise No.	Title of the Exercise	Page No.
Module 1 : DC Generator		
3.1.115	Identify terminals, parts and connections of different types of DC machines	1
3.1.116	Measure field and armature resistance of DC machines	6
3.1.117	Determine build up voltage of DC shunt generator with varying field excitation and performance analysis on load	9
	Method of using a tachometer	10
3.1.118	Test for continuity and insulation resistance of DC machine	14
3.1.120	Perform no load and load test and determine characteristics of series and shunt generators	18
3.1.121	Perform no load and load test and determine characteristics of compound generators (cumulative and differential)	23
3.1.123	Practice dismantling and assembling in DC compound generator	26
Module 2 : DC Motor		
3.2.124	Conduct performance analysis of DC series shunt and compound motors	28
3.2.125	Dismantle and identify parts of three point and four point - DC motor starters	35
3.2.126	Assemble, service and repair three point and four point DC motor starters	37
3.2.127	Practice maintenance of carbon brushes, brush holders, commutator and sliprings	40
3.2.119	Start, run and reverse direction of rotation of DC series, shunt and compound motors	45
3.2.128	Perform speed control of DC motors by field and armature control method	50
3.2.122	Practice dismantling and assembling in DC shunt motor	53
3.2.129	Carry out overhauling of DC machines	56
3.2.130	Perform DC machine winding by developing connecting diagram, test on growler and assemble	59
Module 3 : AC Three Phase Motor		
3.3.131	Identify parts and terminals of three phase AC motors	65
3.3.132	Make an internal connection of automatic star-delta starter with three contactors	69
3.3.133	Connect, start and run three phase induction motor by using DOL, star-delta and auto transformer starters	74
3.3.134	Connect, start, run and reverse direction of rotation of slip-ring motor through rotor resistance starter and determine performance characteristic	81
3.3.135	Determine the efficiency of squirrel cage induction motor by brake test	86
3.3.136	Determine the efficiency of 3 Phase squirrel cage induction motor by no-load test and blocked rotor test	88
3.3.137	Measure slip and power factor to draw speed torque (slip/ torque) characteristics	91
3.3.138	Test for continuity and insulation resistance of three phase Induction motors	93

CONTENTS

Exercise No.	Title of the Exercise	Page No.
3.3.139	Perform speed control of 3-phase induction motors by various methods like rheostatic control, auto transformer etc.	96
3.3.140	Perform winding of three phase AC motor by developing connection diagram, test and assemble	98
3.3.141	Maintain, service and troubleshoot the AC motor starter	110
Module 4 : AC Single Phase Motor		
3.4.142	Identify parts and terminals of different types of single phase AC motors	114
3.4.143	Install connect and determine performance of single phase AC motor	121
3.4.144	Start run and reverse the direction of rotation of single phase AC motors	123
3.4.145	Practice on speed control of a single phase AC motors	128
3.4.146	Compare starting and running winding currents of a capacitor run motor at various loads and measure the speed	130
3.4.147	Carry out maintenance service and repair of AC single phase motors	131
3.4.148	Practice on single /double layer and concentric winding for AC motors, testing and assembling	134
3.4.149	Connect, start, run and reverse the direction of rotation of universal motor	138
3.4.150	Carry out maintenance and servicing of universal motor	140
Module 5 : Alternator		
3.5.151	Install an alternator, identify part and terminals of alternator	142
3.5.152	Test for continuity and insulation resistance of alternator	145
3.5.153	Connect, start and run an alternator and build up the voltage	148
3.5.154	Determine the load performance and voltage regulation of a 3-phase alternator	150
3.5.155	Parallel operation and synchronization of three phase alternators	153
Module 6 : Synchronous Motor and MG Set		
3.6.156	Install a synchronous motor, identify its parts and terminals	158
3.6.157	Connect start and plot V-curves for synchronous motor under different excitation and load conditions	161
3.6.158	Identify the parts and terminals of MG set	163
3.6.159	Start, and load a MG set with 3 phase induction motor coupled to DC shunt generator	165
	Project work	167

ASSESSABLE / LEARNING OUTCOME

On completion of this book you shall be able to

- **Plan, execute commissioning and evaluate performance of DC machines.**
- **Execute testing and maintenance of DC machines and motor starters.**
- **Plan, execute commissioning and evaluate performance of AC motors.**
- **Execute testing and maintenance of AC motors and starters.**
- **Plan, execute testing, evaluate performance and carry out maintenance of Alternator/MG set.**
- **Execute parallel operation of Alternators.**
- **Distinguish organize and perform motor winding.**

SYLLABUS

Third Semester

Duration: Six Month

Week No.	Ref. Learning Outcome	Professional Skills(Trade Practical) with Indicative hours	Professional Knowledge (Trade Theory)
53 - 54	<ul style="list-style-type: none"> • Plan, Execute commissioning and evaluate performance of DC machines 	115. Identify terminals, parts and connections of different types of DC machines. (10 Hrs) 116. Measure field and armature resistance of DC machines. (10 Hrs) 117. Determine build up voltage of DC shunt generator with varying field excitation and performance analysis on load. (15 Hrs) 118. Test for continuity and insulation resistance of DC machine. (5 Hrs) 119. Start, run and reverse direction of rotation of DC series, shunt and compound motors. (10 Hrs)	General concept of rotating electrical machines. Principle of DC generator. Use of Armature, Field Coil, Polarity, Yoke, Cooling Fan, Commutator, slip ring and Brushes, Laminated core etc. E.M.F. equation Separately excited and self excited generators. Series, shunt and compound generators
55 - 56	<ul style="list-style-type: none"> • Plan, Execute commissioning and evaluate performance of DC machines. • Execute testing, and maintenance of DC machines and motor starters 	120. Perform no load and load test and determine characteristics of series and shunt generators. (12 Hrs) 121. Perform no load and load test and determine characteristics of compound generators (cumulative and differential). (13 Hrs) 122. Practice dismantling and assembling in DC shunt motor. (12 Hrs) 123. Practice dismantling and assembling in DC compound generator. (13 Hrs)	Armature reaction, Commutation, inter poles and connection of inter poles. Parallel Operation of DC Generators. Load characteristics of DC generators. Application, losses & efficiency of DC Generators. Routine & maintenance
57 - 58	<ul style="list-style-type: none"> • Plan, Execute commissioning and evaluate performance of DC machines. • Execute testing, and maintenance of DC machines and motor starters 	124. Conduct performance analysis of DC series, shunt and compound motors. (15 Hrs) 125. Dismantle and identify parts of three point and four point DC motor starters. (10 Hrs) 126. Assemble, Service and repair three point and four point DC motor starters. (15 Hrs)	Principle and types of DC motor. Relation between applied voltage back e.m.f., armature voltage drop, speed and flux of DC motor. DC motor Starters, relation between torque, flux and armature current. Changing the direction of rotation.

		127. Practice maintenance of carbon brushes, brush holders, Commutator and slip-rings. (10 Hrs)	Characteristics, Losses & Efficiency of DC motors. Routine and maintenance
59 - 60	<ul style="list-style-type: none"> Execute testing, and maintenance of DC machines and motor starters. Distinguish, organise and perform motor winding 	<p>128. Perform speed control of DC motors - field and armature control method. (10 Hrs)</p> <p>129. Carry out overhauling of DC machines. (15 Hrs)</p> <p>130. Perform DC machine winding by developing connection diagram, test on growler and assemble. (25 Hrs)</p>	Methods of speed control of DC motors. Lap and wave winding and related terms
61 - 62	<ul style="list-style-type: none"> Plan, Execute commissioning and evaluate performance of AC motors. Execute testing, and maintenance of AC motors and starters 	<p>131. Identify parts and terminals of three phase AC motors. (5 Hrs)</p> <p>132. Make an internal connection of automatic star-delta starter with three contactors. (10 Hrs)</p> <p>133. Connect, start and run three phase induction motors by using DOL, star-delta and auto-transformer starters. (20 Hrs)</p> <p>134. Connect, start, run and reverse direction of rotation of slip-ring motor through rotor resistance starter and determine performance characteristic. (15 Hrs)</p>	Working principle of three phase induction motor. Squirrel Cage Induction motor, Slip-ring induction motor; construction, characteristics, Slip and Torque. Different types of starters for three phase induction motors, its necessity, basic contactor circuit, parts and their functions
63 - 64	<ul style="list-style-type: none"> Plan, Execute commissioning and evaluate performance of AC motors. Execute testing, and maintenance of AC motors and starters 	<p>135. Determine the efficiency of squirrel cage induction motor by brake test. (8 Hrs)</p> <p>136. Determine the efficiency of three phase squirrel cage induction motor by no load test and blocked rotor test. (8 Hrs)</p> <p>137. Measure slip and power factor to draw speed-torque (slip/torque) characteristics. (14 Hrs)</p> <p>138. Test for continuity and insulation resistance of three phase induction motors. (5 Hrs)</p>	Single phasing prevention. No load test and blocked rotor test of induction motor. Losses & efficiency. Various methods of speed control. Braking system of motor. Maintenance and repair

		139. Perform speed control of three phase induction motors by various methods like rheostatic control, autotransformer etc. (15 Hrs)	
65	<ul style="list-style-type: none"> Distinguish organise and perform motor winding 	<p>140. Perform winding of three phase AC motor by developing connection diagram, test and assemble. (20 Hrs)</p> <p>141. Maintain, service and troubleshoot the AC motor starter. (05 Hrs)</p>	Concentric/ distributed, single/ double layer winding and related terms
66 - 67	<ul style="list-style-type: none"> Plan, Execute commissioning and evaluate performance of AC motors. Execute testing, and maintenance of AC motors and starters 	<p>142. Identify parts and terminals of different types of single phase AC motors. (5 Hrs)</p> <p>143. Install, connect and determine performance single phase AC motors. (15 Hrs)</p> <p>144. Start, run and reverse the direction of rotation of single phase AC motors. (10 Hrs)</p> <p>145. Practice on speed control of single phase AC motors. (10 Hrs)</p> <p>146. Compare starting and running winding currents of a capacitor run motor at various loads and measure the speed. (10 Hrs)</p>	<p>Working principle, different method of starting and running of various single phase AC motors.</p> <p>Domestic and industrial applications of different single phase AC motors.</p> <p>Characteristics, losses and efficiency</p>
68 - 69	<ul style="list-style-type: none"> Distinguish organise and perform motor winding 	<p>147. Carry out maintenance, service and repair of single phase AC motors. (10 Hrs)</p> <p>148. Practice on single/double layer and concentric winding for AC motors, testing and assembling. (25 Hrs)</p> <p>149. Connect, start, run and reverse the direction of rotation of universal motor. (10 Hrs)</p> <p>150. Carry out maintenance and servicing of universal motor. (05 Hrs)</p>	<p>Concentric/ distributed, single/ double layer winding and related terms.</p> <p>Troubleshooting of single phase AC induction motors and universal motor</p>

70 - 71	<ul style="list-style-type: none"> Plan, execute testing, evaluate performance and carry out maintenance of Alternator / MG set. Execute parallel operation of alternators 	<p>151. Install an alternator, identify parts and terminals of alternator. (10 Hrs)</p> <p>152. Test for continuity and insulation resistance of alternator. (5 Hrs)</p> <p>153. Connect, start and run an alternator and build up the voltage. (10 Hrs)</p> <p>154. Determine the load performance and voltage regulation of three phase alternator. (10 Hrs)</p> <p>155. Parallel operation and synchronization of three phase alternators. (15 Hrs)</p>	<p>Principle of alternator, e.m.f. equation, relation between poles, speed and frequency. Types and construction. Efficiency, characteristics, regulation, phase sequence and parallel operation. Effect of changing the field excitation and power factor correction</p>
72	<ul style="list-style-type: none"> Plan, execute testing, evaluate performance and carry out maintenance of Alternator / MG set 	<p>156. Install a synchronous motor, identify its parts and terminals. (10 Hrs)</p> <p>157. Connect, start and plot V curves for synchronous motor under different excitation and load conditions. (15 Hrs)</p>	<p>Working principle of synchronous motor. Effect of change of excitation and load. V and anti V curve. Power factor improvement</p>
73	<ul style="list-style-type: none"> Plan, execute testing, evaluate performance and carry out maintenance of Alternator / MG set 	<p>158. Identify parts and terminals of MG set. (5 Hrs)</p> <p>159. Start and load MG set with 3 phase induction motor coupled to DC shunt generator. (20 Hrs)</p>	<p>Rotary Converter, MG Set description and Maintenance</p>
74 - 75		<p>Project work/Industrial visit (optional)</p> <p>Broad Areas:</p> <ol style="list-style-type: none"> Phase sequence checker for 3 phase supply Induction motor protection system Motor starters with protection Solar/wind power generation 	
76 - 77		Revision	
78		Examination	

Identify terminals, parts and DC connections of different types of DC machines

Objectives: At the end of this exercise you shall be able to

- read and interpret the name-plate details of the given DC machine
- determine the pairs of terminals of the windings of the DC machine by the test lamp method
- test and identify the field and armature terminals of DC machine by the test lamp method
- Identify the parts of DC machines
- connect different types of DC machines.

Requirements	
<p>Tools/Instruments</p> <ul style="list-style-type: none"> • Insulated combination pliers 200mm - 1 No. • Screwdriver 150mm - 1 No. • D.E. spanner set 5mm to 20mm - 1 No. (For a group of seven) <p>Equipment/Machines</p> <ul style="list-style-type: none"> • DC compound machine 220V or 440V rating - 1 No. • Dismantled DC machine - 1 No. 	<p>Materials</p> <ul style="list-style-type: none"> • P.V.C. Insulated cable 3/20 of 660 V grade - 5 m • Kit-kat fuse unit 250V, 16A - 1 Set • Pendant lamp-holder 240V, 6A - 1 No. • S.P.T. switch 240V, 6A - 1 No. • B.C. lamp 25/40 watt, 240V - 1 No. • Fuse wire 5A - as reqd. • Cleaning cloth - as reqd.

PROCEDURE

TASK 1: Read and interpret the name plate details and identify the terminals of a DC compound machine

- 1 Read the name-plate details of the given DC compound machine and record them in Table 1.

Table 1

Name-plate details

Manufacturer	_____		
Type, model	_____		
Type of current	_____		
Function.	_____ generator/motor		
Serial number	_____		
Type of connection	_____ sep/shunt/series/compound		
Rated voltage	_____ volts	Rated current	_____ amps
Rated power	_____ k.w.	Rated speed	_____ .r.p.m.
Rated exc.voltage	_____ volts	Rated Exc.current	_____ amps
Rating class.	_____	Direction of rotation	_____
Insulation class	_____	Protection class	_____

- 2 Remove the terminal box cover and sketch the layout of the terminals in the space given in Fig 1a.

Do not spoil screw heads or nuts nor lose them while removing the terminal cover.

As there is no marking on the terminals, give your own marking as shown in Fig 1b.

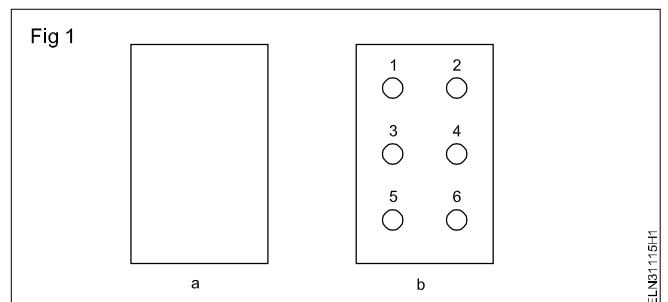

TASK 2: Test and identify the pairs of terminals of a DC compound machine

1 Prepare a test lamp for 240V 25W. (Fig 2)

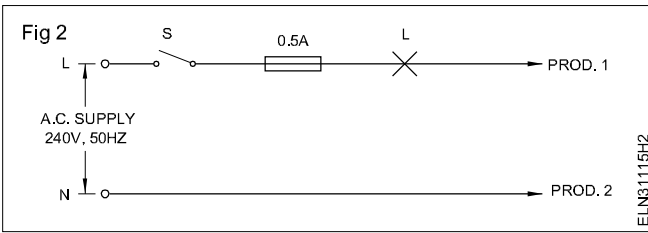

Identify one of the cables as the phase cable and connect it to the test lamp through the switch and fuse.

Care should be taken to avoid any part of your body coming in contact with the bare portion of the prods since 240V AC voltage is dangerous, and may cause shock hazards.

Keep the switch in the 'off' position when the test lamp is not in use.

2 Connect Prod 1 of the test lamp to terminal 1 and touch the other Prod 2 to the rest of the terminals, one by one. (Fig 3 a)

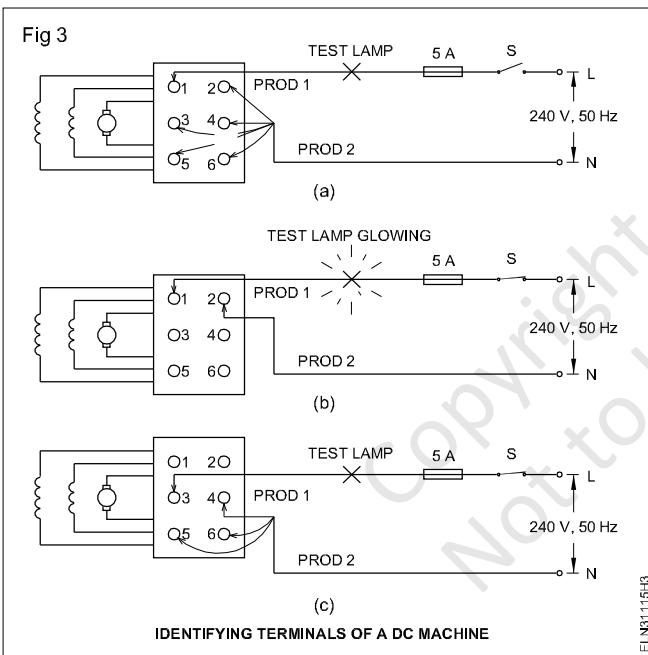

3 Check the condition of the lamp.

If the lamp lights (Fig 3b) while touching any one of the other terminals, then the terminal connected to Prod 1 and Prod 2 form pairs of the same circuit. Record the observations in Table 2.

Table 2

Sl. No.	Pairs of terminals	Condition of lamps	Identification
1	1 and 2		
2	1 and 3		
3	1 and 4		
4	1 and 5		
5	1 and 6		
6	3 and 4		
7	3 and 5		
8	3 and 6		
9	5 and 6		
10	Brush to -- 2		
11	Brush to -- 3		
12	Brush to -- 5		

4 Connect Prod 1 of the test lamp to another terminal as shown in Fig 3c and repeat the procedure of steps 2 and 3 to find the second pair of terminals and write the results in Table 2.

The test lamp burns bright in both armature and series field terminals as the respective inductive reactance are of low value, whereas in the shunt field circuit the light may burn dim, or prods when touched, may give some spark only due to high inductive reactance therein.

Conclusion

Armature terminals _____ and _____
(Mark them as A₁ & A₂.)

Shunt field terminals _____ and _____.
(Mark them as E₁ & E₂.)

Series field terminals _____ and _____
(Mark them as D₁ & D₂.)

5 Check the other two left out terminals, to ascertain whether they belong to the same pairs of terminals.

The pairs of terminals in which the lamp either burns dim or the prod contact point gives spark as shown in Fig 4a form the shunt field terminals.

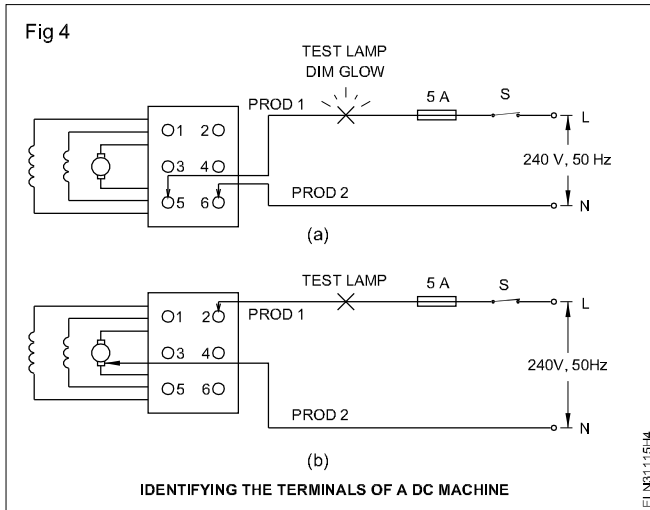

Mark them in Fig 1b as E_1 & E_2 and record the same in Table 2.

Note: You might have observed in this experiment the lamp glows rather brightly at two sets or pairs of terminals. They belong to the armature and series fields. To distinguish the pair of armature terminals out of the two pairs, follow the steps as given in Task 3.

TASK 3: Identify the armature terminals pair out of 2 pairs of low resistive terminals

- 1 Connect prod 1 to any one of the identified low resistive (where lamp was burning bright) pairs. (Fig 4b)
- 2 Touch prod 2 to any one of the brushes. (Fig 4b)
- 3 If the test lamp burns, then that pair belongs to the armature terminals. If not, try the other pairs. Mark the terminals as A_1 and A_2 in (Fig 1b) and also enter in Table 2.
- 4 The remaining two terminals will be of series field terminals. Mark them as D_1 and D_2 in (Fig 1b) and also enter in Table 2.
- 5 Show the results to your instructor.

Take care that the prod does not touch the body/frame of the machine or any other metal part except the brush.

TASK 4: Identify the parts of DC machines

- 1 Read and interpret the name plate details of the DC machine.
- 2 Identify the parts of the DC machine.
- 3 Put the label on each parts with numbers.(Fig 5)
- 4 Record the name of the parts and draw the sketches of each parts in table 3.

Table 3

SI.No.	Label No	Name of the parts	Draw the sketches of the parts
1	2		
2	3		
3	1		
4	5		
5	9		
6	8		
7	7		
8	4		
9	10		
10	6		

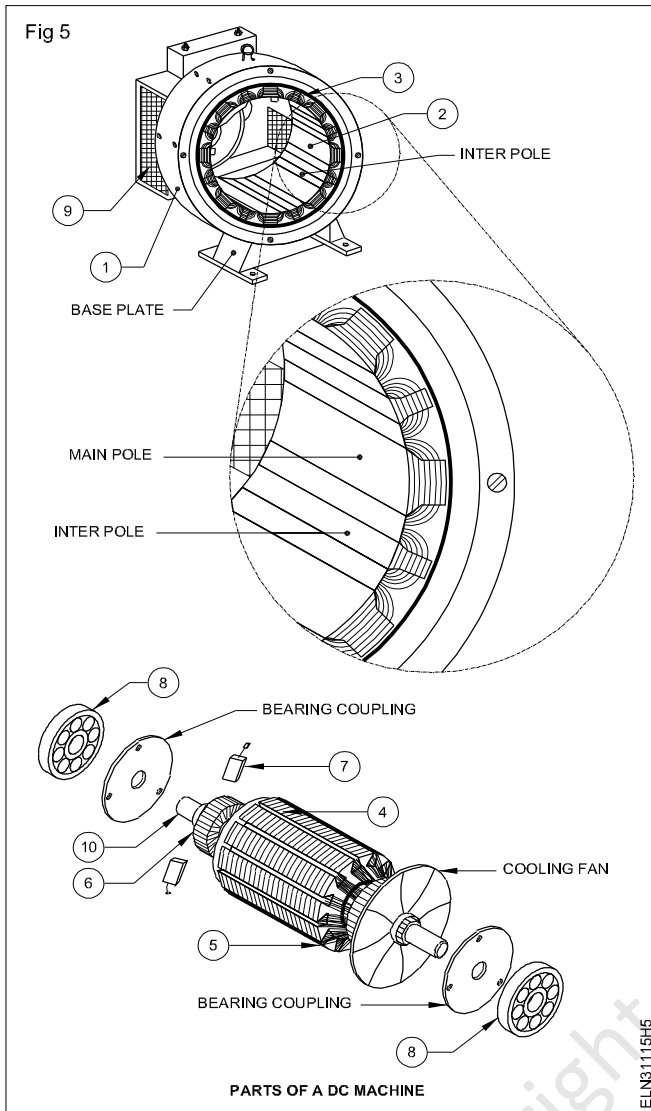

TASK 5 : Identify terminals and connect DC shunt generator

- 1 Connect the machine as per the connection diagram. (Fig 6)
- 2 Connect field winding to the armature terminal in parallel. (Fig 6)

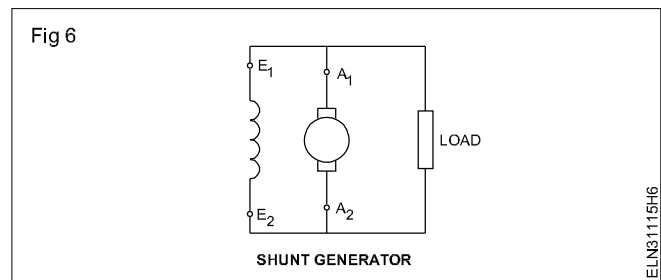

TASK 6 : Identify terminals and connect DC series generator

- 1 Connect the machine as per the connection diagram. (Fig 7)
- 2 Connect field winding in series with the armature. (Fig 7)

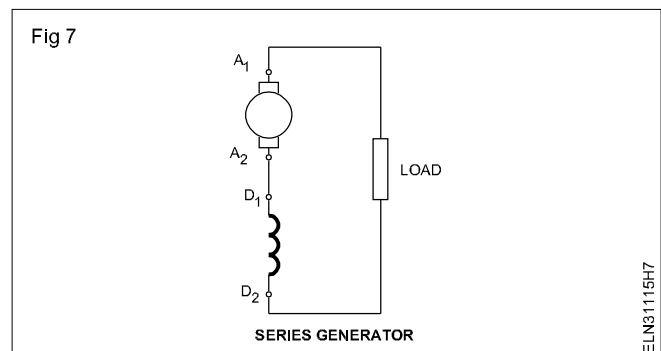

TASK 7 : Identify terminals and connect various DC compound generator

- 1 Connect the machine as per the connection diagram (Fig 8).
- 2 Provide the field excitation by a combination of shunt and series field windings.
- 3 Connect the shunt field directly across the armature (Fig 8).

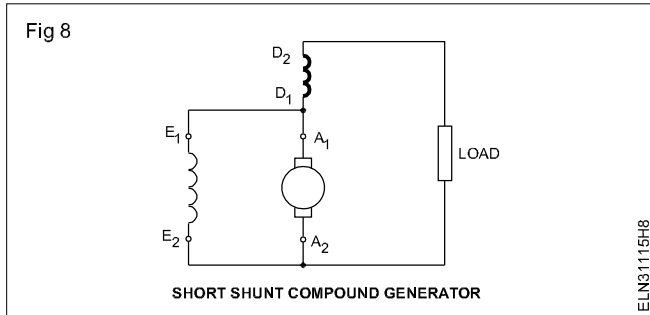

- 4 The shunt field is connected in parallel with the series combination of armature and series field. (Fig 9)

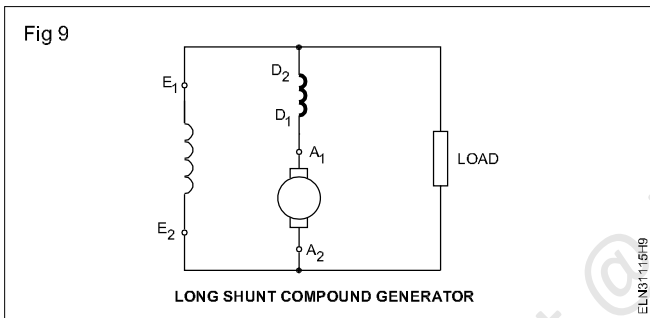

- 5 Connect the machine as per the connection diagram (Fig 10 & 11) for short shunt cumulative compound and short shunt differential compound generator.
- 6 Connect the machine as per the connection diagram (Fig 12 & 13) for differential long shunt cumulative compound and long shunt differential compound generator.

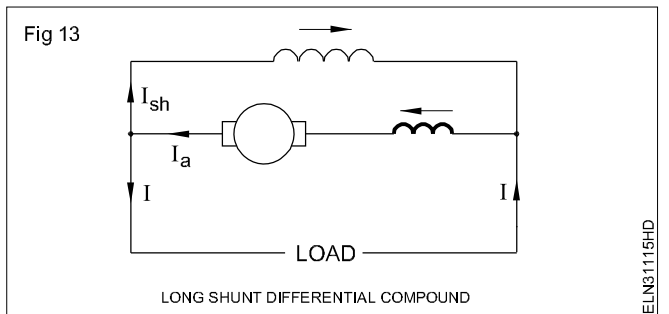
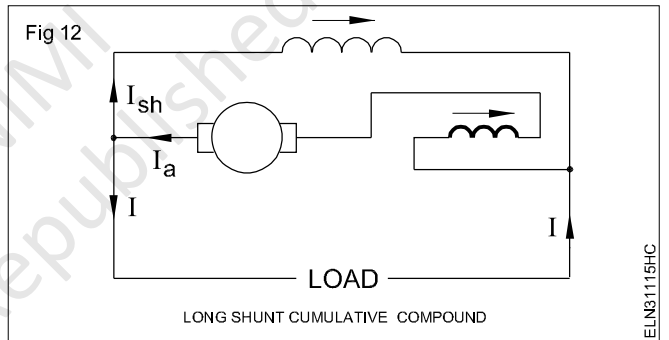
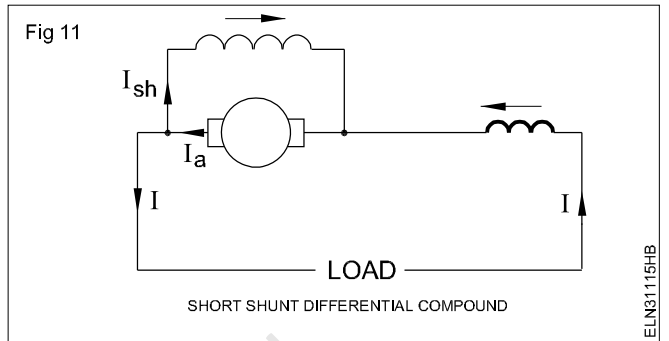
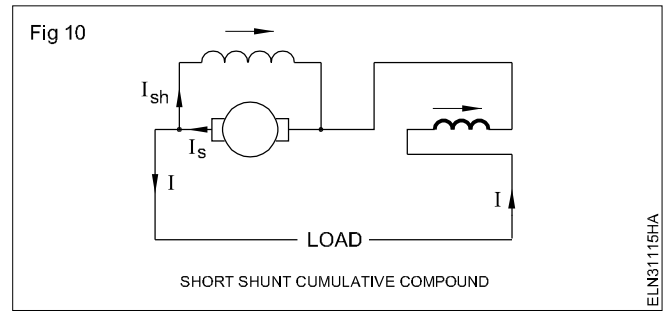

Measure field and armature resistance of DC machines

Objectives: At the end of this exercise you shall be able to

- read and interpret the name-plate details of a DC machine
- test and identify the terminals of a DC machine
- measure the shunt field resistance of a DC machine by the voltmeter and ammeter method
- measure the shunt field resistance of a DC machine by the ohmmeter method and compare the results
- measure the armature resistance using a voltmeter and ammeter
- measure and verify armature resistance by the ohmmeter method.

Requirements			
Tools/Instruments		Equipment/Machines	
• Screwdriver 150 mm	- 1 No.	• Car battery 24V, 100 AH	- 1 No.
• Insulated combination pliers 150 mm	- 1 No.	• Rheostat 250 ohms, 1 ampere	- 1 No.
• D.E. spanner set 5mm to 18mm	- 1 Set	• DC compound machine 220V/ 3KW	- 1 No.
• M.C. voltmeter 0 to 25V	- 1 No.	• Rheostat 10 ohm 5 A	- 1 No.
• M.C. ammeter 0 to 100 milliamperes	- 1 No.	Materials	
• Series/ shunt type ohmmeter 0-50 ohms	- 1 No.	• PVC Insulated copper cable 1.5 sq mm	- 5 m
• M.C. ammeter 0 to 5A	- 1 No.	• Crocodile clips 16A	- 4 Nos.
• M.C. voltmeter 0 to 500V	- 1 No.	• Test lamp	- 1 No.

PROCEDURE

TASK 1 : Read and interpret the name plate details of a DC machine

- 1 Note down the name-plate details of the given machine in Table 1.
- 2 Remove the terminal cover.

Use proper tools and avoid damage to the screw heads.
Keep the screws in a tray.

Table 1
Name-plate details

Manufacturer _____

Type, model _____

Type of current _____

Function. _____ generator/motor

Fabrication or serial number. _____

Type of connection _____ sep/shunt/series/compound

Rated voltage _____ volts Rated current. _____ amps

Rated power _____ k.w. Rated speed _____ .r.p.m.

Rated exc.voltage. _____ volts Rated Exc.current.. _____ amps

Rating class. _____ Direction of rotation. _____

Insulation class _____ Protection class _____

- 3 Identify DC machines terminals.

TASK 2: Measure the shunt field resistance by the voltmeter and ammeter method

1 Connect the circuit as per Fig 1 and get the approval of the instructor.

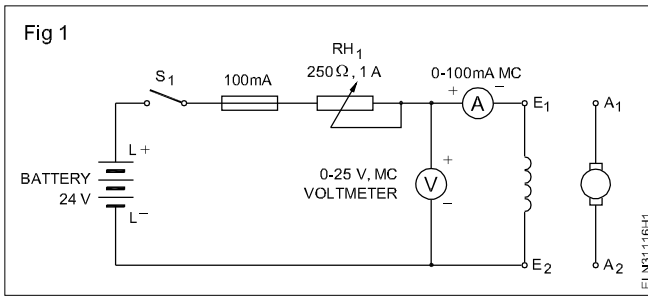

- Switch 'on' the circuit and adjust the rheostat to get 20 mA.
- Read and record the voltmeter and milli-ammeter readings in Table 2.

Table 2

Sl. No.	mA	Volts	$R_{sh} = V/mA$ Kohms	Average value shuntfield resist- ance in ohms
1	20			
2	40			
3	60			
4	80			
5	100			

- Repeat steps 2 and 3 for 40, 60, 80 and 100 mA current ratings.
- Switch off the circuit and complete the tabular columns.
- Calculate the average value of the field resistance and show it to the instructor.
- Disconnect the circuit after getting the approval by the instructor.

If the specified range of meters or supply is not available, it can be carried out, as shown in Fig 2, by using suitable meters and 220V DC.

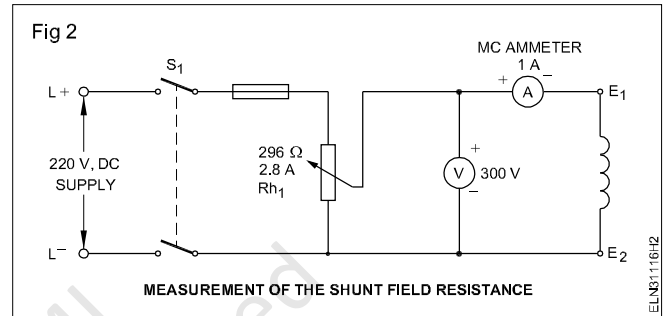

Fig 2

MEASUREMENT OF THE SHUNT FIELD RESISTANCE

TASK 3 : Measure shunt field resistance by an ohmmeter

1 Take a series type ohmmeter or multimeter; select a proper ohmic range and set its value to zero by shorting the prods.

Use a series type ohmmeter to measure high value resistance.

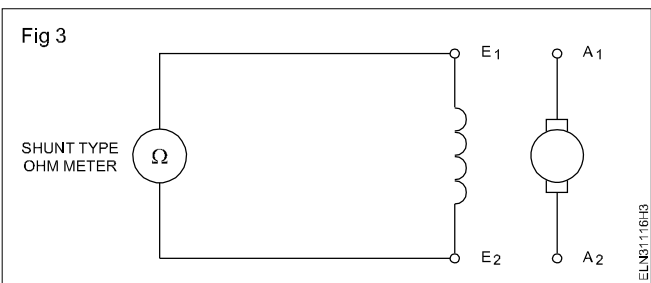
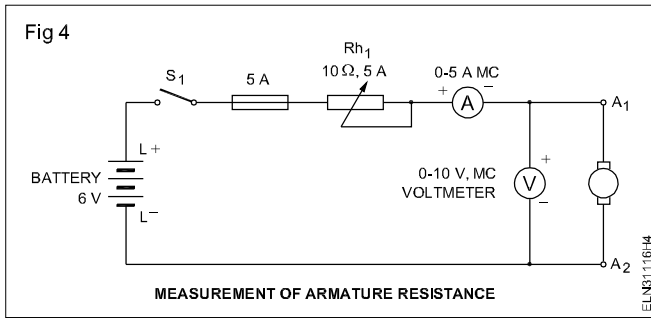

Fig 3

- Connect the meter leads to the shunt field terminals of the machine as per the Fig 3.
- Read, and record the value of the shunt field resistance below. The value of the shunt field resistance is _____ ohms.
- Refix the terminal cover.
- Compare the readings obtained in Tasks 1 and 2. If there is any difference write the reasons in the space given below.

TASK 4: Measure the armature resistance using a voltmeter and ammeter

- 1 Connect the armature terminals to the ammeter, voltmeter, fuses, rheostat Rh₁ and the battery. (Fig 4)



- 2 Keep the rheostat Rh₁ in cut 'in' position. Then switch 'on' the circuit.

Sometimes the armature starts rotating slowly during the experiment. In such cases hold the armature in a steady position by hand to avoid erroneous reading.

- 3 Adjust the reading of the ammeter to 0.5 amperes by adjusting Rh₁.

Move the armature to different positions by hand and see that the reading remains constant.

- 4 Read and record the volt and ammeter readings in Table 3.

Table 3

Sl. No.	Amps.	Volts	R =V/I	Average Value of armature resistance
1	0.5			
2	1			
3	1.5			
4	80			
5	100			

- 5 Repeat steps 3 and 4 for 1, 1.5, 2 and 2.5 amperes current ratings.
- 6 Switch 'OFF' the circuit.
- 7 Complete the remaining columns of the table, find the average value of the armature resistance and show the results to the instructor.
- 8 Disconnect the circuit after getting by the approval of the instructor.

TASK 5: Measure armature resistance using an ohmmeter

- 1 Adjust ohms 'Zero' and ohms 'Infinity' of the ohmmeter.

Use a shunt type ohmmeter to measure the low value resistance of the armature.

- 2 Connect the ohmmeter across the armature terminals (Fig 5) and measure the resistance.

Move the armature to different positions by hand and see that the reading remains constant.

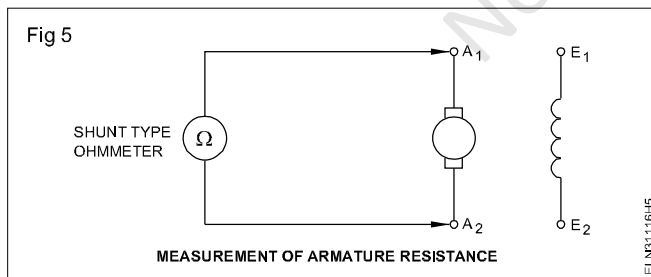

- 3 Note down the meter reading and record it below.
Armature resistance value is _____ ohms.
- 4 Replace the terminal cover and keep all tools, equipment and meters at their places.
- 5 Compare the readings of Task 1 & 2. If there is any difference, find the reasons for that and write your conclusions in the space below.

Conclusion

Determine build up voltage of DC shunt generator with varying field excitation and performance analysis on load

Objectives: At the end of this exercise you shall be able to

- test and identify the terminals of a DC shunt generator
- measure the voltage due to residual magnetism or create residual magnetism, if necessary
- measure the speed of a DC shunt generator with the help of a revolution counter and stopwatch
- build up voltage in a self-excited DC shunt generator
- determine the relation between field current and induced emf (magnetisation characteristic) in a DC shunt generator when the speed is constant
- connect a DC shunt generator and build up the voltage
- load the DC shunt generator
- determine the load performance characteristic of the DC shunt generator at different loads.

Requirements	
<p>Tools/Instruments</p> <ul style="list-style-type: none"> • Combination pliers 200mm - 1 No. • Screwdriver 150mm - 1 No. • Electrician's knife 100mm - 1 No. • Revolution counter 4 digits - 1 No. • Stopwatch - 1 No. • Ammeter MC 0-1A - 1 No. • Voltmeter MC 0-300V - 1 No. • M.C ammeter 0-20A - 1 No. 	<p>Equipment/Machines</p> <ul style="list-style-type: none"> • DC shunt generator 2 or 4 KW 220V - 1 No. • Rheostat 296 ohms 2.8 Amps - 1 No. • Knife switch D.P.S.T. 16A - 1 No. • Knife switch S.P.S.T. 16A - 1 No. • Lamp load 220v/5kw - 1 No. <p>Materials</p> <ul style="list-style-type: none"> • P.V.C. Insulated cable 2.5 sq.mm - 5 m • Fuse wire 10 A - 0.2 m • P.V C Insulated flexible cable 14/0.2 - 2 m

PROCEDURE

TASK 1: Build up voltage of a DC shunt generator

- 1 Read and interpret the name-plate details of the given DC shunt generator and record them in Table 1.
- 2 Identify the terminals of the given DC shunt generator.
- 3 Connect the circuit as per Fig 1.

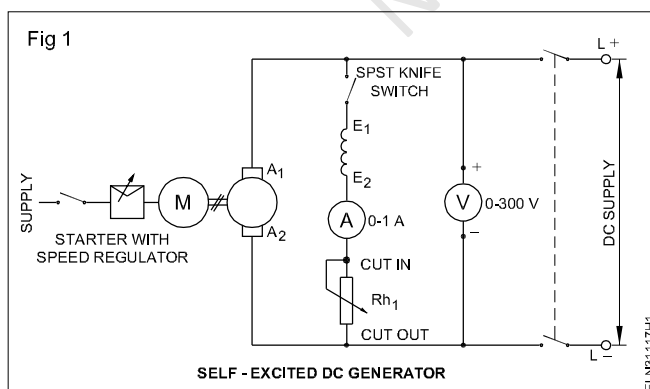

- 4 Keep the field switch open and the field rheostat in the cut 'in' position. Get the approval of the instructor.
- 5 Start the prime mover coupled to the DC shunt generator.

The direction of rotation must be according to the direction marked on the DC generator. If not, change the direction of the rotation of the prime mover.

- 6 Measure the speed of the generator with the help of the revolution counter and stopwatch.

The number of revolutions made by a machine in a minute gives the r.p.m.

- 7 Adjust the prime mover speed such that the generator runs at its rated speed.

Keep the speed constant throughout the experiment.

- 8 Measure the voltage induced across the armature and note down the measured value in Table 1.

This induced voltage is due to the residual magnetism as the field current is zero. If the residual magnetism is absent in the field poles, then there will be no residual voltage. In such a case the residual magnetism could be recreated by connecting the field winding to a DC source such as a battery for a short time.

- 9 Close the field circuit switch and gradually increase the field current to 0.1 ampere by reducing the resistance of the field rheostat.

Increase the field current only till the induced voltage reaches just above 125% of the rated value. Check the speed of the generator at intervals. If necessary, adjust it to the rated value.

If the generator is not able to build up voltage even though it is running in the marked direction, switch off the prime mover and then interchange the field terminals of the generator. While varying the field rheostat/regulator it should be done positively and slowly in the forward direction. Reverse movement should be avoided.

- 11 Switch 'OFF' the DC generator and the prime mover.
12 Draw the graph keeping the induced voltage in the 'Y' axis and the field current in the X axis.

The graph shows the magnetisation / no-load characteristic of the DC shunt generator.

- 10 Increase the field current slowly in steps of 0.1 ampere, and for each step, note down the field current and the corresponding induced voltage. Record them in Table 1.

- 13 Show your readings and graph to your instructor.

Table 1

Sl. No.	Field current in amps	Induced voltage in volts	Speed (held at constant rated value throughout the experiment)
1			
2			
3			
4			
5			

Skill Sequence

Method of using a tachometer

Objective: This shall help you to
• measure speed using a tachometer.

A hand tachometer (Fig 1) is a portable instrument and is used for measuring the speed of the rotating machinery.

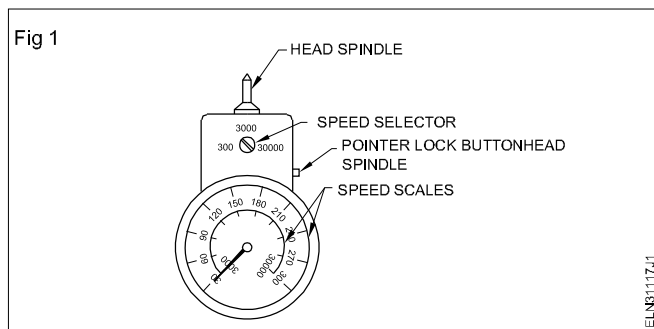

To use a hand tachometer (Fig 2)

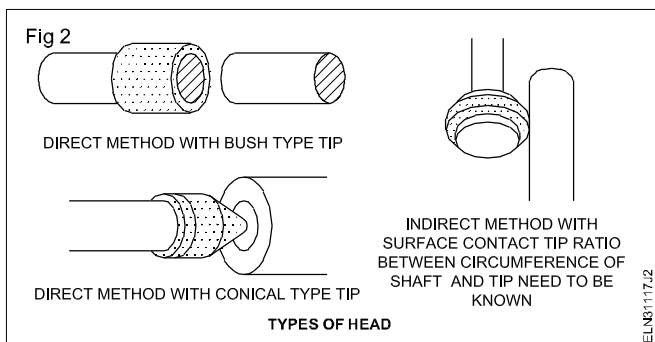

- Select and fit the correct head
- Select the highest speed range on the tachometer if the speed is not known (Fig 3)

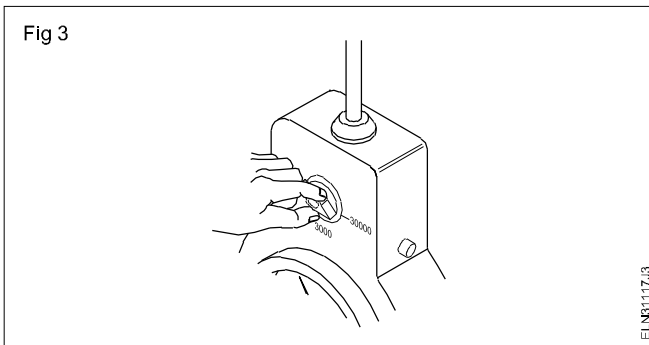

- Hold the tachometer gently against the shaft. (Fig 4)

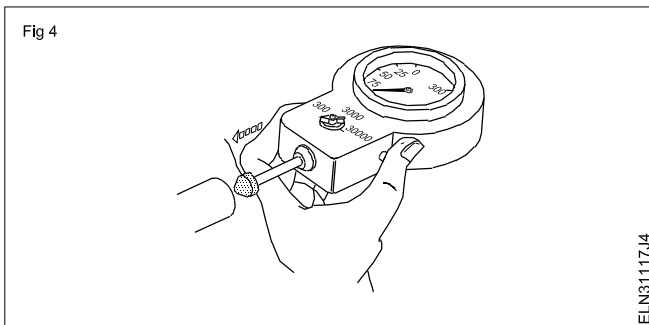

- Depress the pointer lock button when the pointer has settled. (Fig 5)

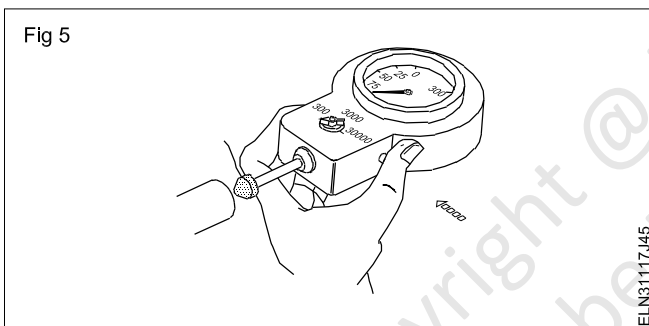

- Remove the tachometer from the shaft to take a reading (Fig 6).

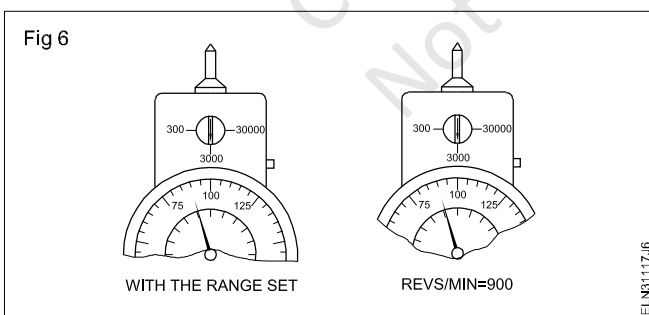

- Take a reading using the correct scale for the speed range. (Fig 7)

If the reading is within a lower speed range, use the next lower range to take a new reading for a more accurate result. (Fig 7)

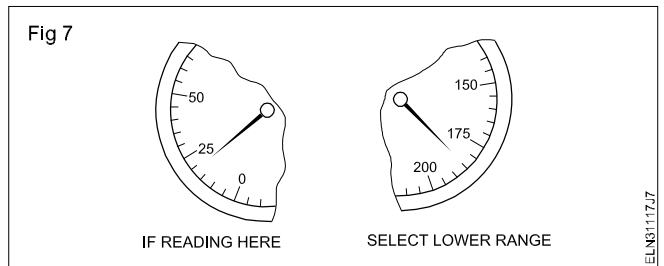

Note: A tachometer will measure linear speed when the disc head is fitted (Fig 8).

To determine the speed of the shaft follow the method stated below.

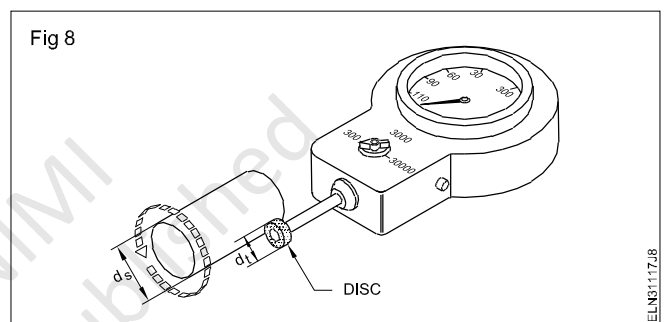

Let the speed indicated by the tachometer be - N_T r.p.m.

Let the diameters of the head (tip) be - d_T cms.

Let the diameter of the shaft be d_s cms.

Linear displacement of the head (tip) - $\pi d_T \times N_T$ cms.

Let the speed of the shaft be N_s r.p.m.

Linear displacement of the shaft $\pi d_s N_s$ cms.

Hence $\pi d_T N_T = \pi d_s N_s$

Shaft speed $N_s = \frac{\pi d_T N_T}{\pi d_s}$ r.p.m.

$= \frac{d_T}{d_s} N_T$ r.p.m.

TASK 2 : Determine performance analysis of DC shunt generator on different loads

- 1 Measure the armature resistance and enter the value in Table 2.
- 2 Select appropriate cables, switch, load and meters, according to the capacity of the given DC shunt generator.
- 3 Connect the meters, rheostat and lamp load with the terminals of the DC shunt generator (Fig 9). (If a lamp load is not available, a water load can be used.)
- 4 Keep the load switch open and also switch 'off' all the circuit switches in the lamp load.
- 5 Keep the field regulator resistance in 'cut-in' position.
- 6 Start the prime mover and bring it to the rated speed of the generator.
- 7 By adjusting the field rheostat, build up the voltage of the generator to its rated value. Enter the value of the open circuit voltage in Table 2.

Make yourself clear about the method of starting the prime mover and the procedure of adjusting its speed.

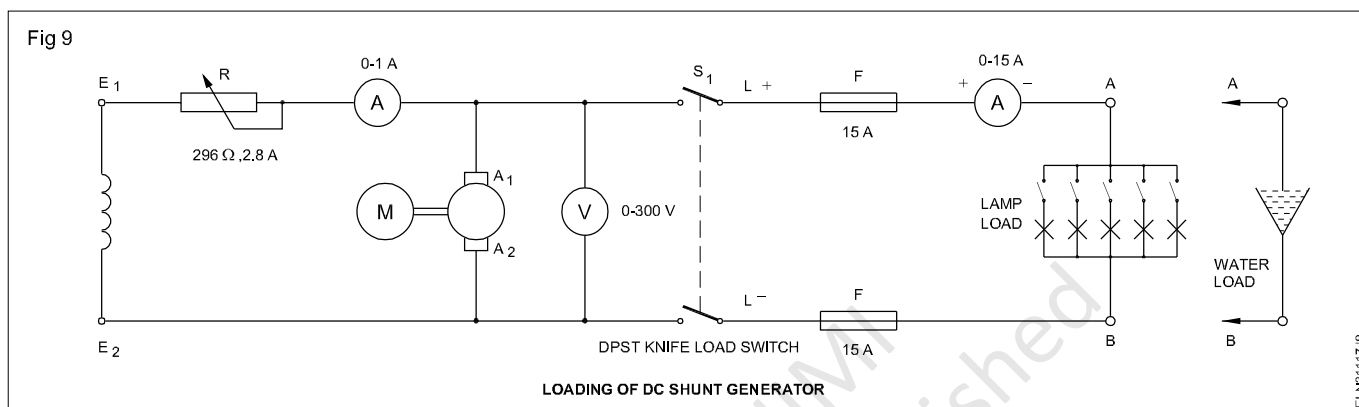

Table 2

Sl.No.	Terminal voltage 'V'(Volts)	Load current I_L	Shunt field current (I_{sh}) kept constant	Armature current $I_a = I_L + I_{sh}$	Induced emf $E = V + I_a R_a$	Remarks
1						Armature resistance = ohms
2						
3						
4						
5						
6						

Remember

- 8 Determine open circuit voltage $V = E - I_a \cdot R_a$
where E is the induced emf
 I_a is the armature current
 R_a is the armature resistance.

- 9 Determine the armature current $I_a = I_L + I_{sh}$
where I_L is the load current
 I_{sh} is the field current.

In the case of no load $I_L = 0$
hence $I_a = I_{sh}$.

Therefore, at no load, the terminal voltage comes to
 $V = E - (0 + I_{sh}) \cdot R_a$.

- 10 Close the load switch and gradually load the generator by switching 'ON' a few lamps.
- 11 Read the corresponding terminal voltage, shunt field current, load current, and record them in Table 2.

Check the speed of the generator at intervals, and adjust it to the rated value.

- 12 Increase the load current up to 125% of its rated value in 6 or 8 equal steps.

- 13 Note down the corresponding terminal voltage and field current for each step of load current in Table 2 .
- 14 Gradually reduce the load current to zero and switch 'OFF' the load circuit and the prime mover.
- 15 Show the record of your readings to the instructor and get his approval.
- 16 Draw the graph of the external characteristic of a DC shunt generator by keeping the terminal voltage in the Y-axis and the load current in the X-axis. (Fig 10)
- 17 Show the graph to your instructor and get his approval.
- 18 Disconnect the circuit.

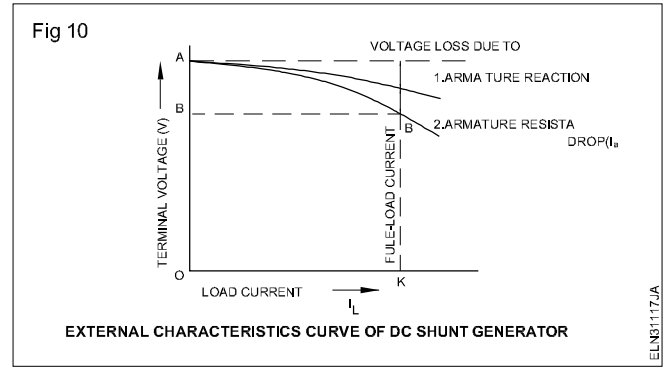

Copyright @ NIMI
Not to be Republished

Test for continuity and insulation resistance of DC machine

Objectives: At the end of this exercise you shall be able to

- test a DC machine for continuity with a megger
- test a DC machine for insulation resistance between windings with a megger
- test a DC machine for insulation resistance between windings and body with a megger.

Requirements	
Tools/Instruments	Equipment/Machines
<ul style="list-style-type: none"> • Insulated cutting pliers 150 mm - 1 No. • Megger 500V - 1 No. • Screwdriver 150 mm - 1 No. • D/E spanner set 5 to 18mm - 1 Set 	<ul style="list-style-type: none"> • DC compound machine of any rating - 1 No.
	Materials
	<ul style="list-style-type: none"> • PVC Insulated flexible copper cable 24/0.2 mm - 4 m • Crocodile clips 16 amps - 2 Nos.

PROCEDURE

TASK 1: Test a DC machine for continuity

- 1 Switch off the designated main switch of the DC machine and remove the fuse-carriers.
- 2 Note the name-plate details in Table 1. (As given in exercise 3.1.115)
- 3 Identify the pairs of the terminals from the marking.
- 4 Test the continuity of the armature terminals A_1 and A_2 . (Fig 1a)
- 5 Test the continuity of the series field terminals D_1 and D_2 (Fig 1b) using a Megger.
- 6 Test the continuity of the shunt field terminals E_1 and E_2 (Fig 1c) using a Megger.

Continuity between the terminals of the same winding is a must. In case of no continuity, inform the instructor immediately. You can proceed for insulation test, only when there is continuity between the terminals of the same winding. However, at certain times, the continuity test will not reveal internal short circuits. The best method is to measure the resistance of the winding, and compare it with the previous reading to check the correctness.

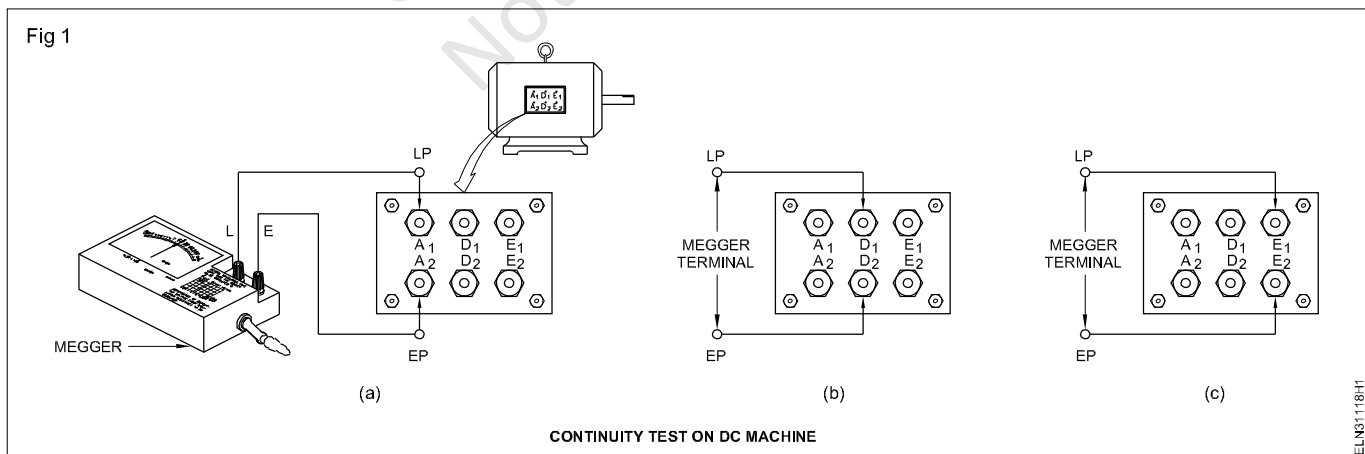

TASK 2: Test a DC machine for insulation resistance between windings

- 1 Fill up the columns 1 to 4 in Table 1.
- 2 Connect the Megger between armature and shunt field terminals. (Fig 2a)
- 3 Rotate the Megger at its rated speed, and note down the reading in Table 1.
- 4 Repeat step 3 for testing the insulation between the shunt field and series field after connecting the Megger terminals. (Fig 2b)
- 5 Connect the Megger (Fig 2c) to measure the insulation resistance between the armature and series field.
- 6 Repeat step 3.

The measured value should not be less than 1 megohm.

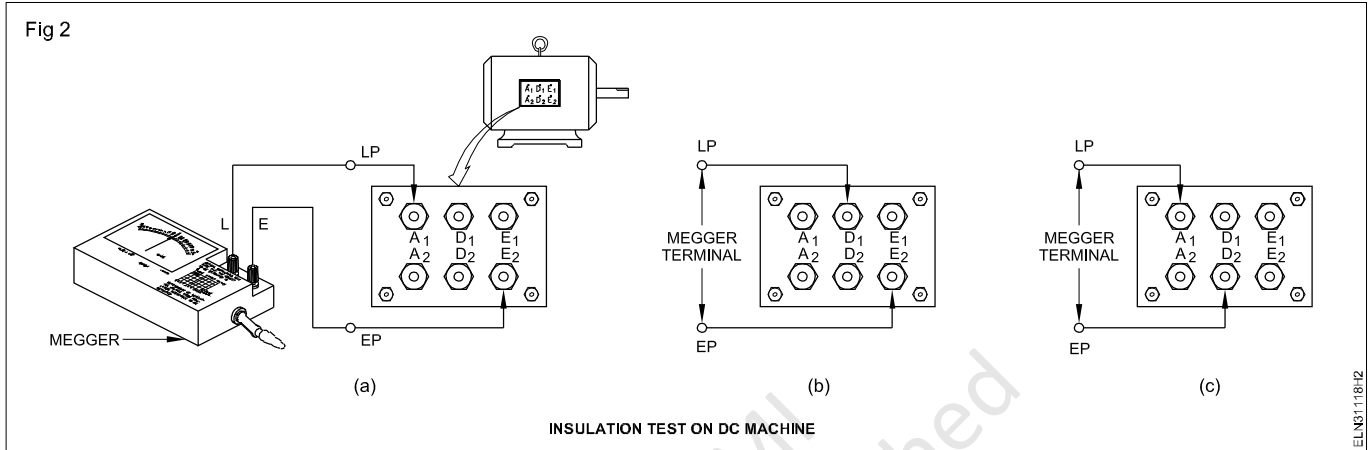

Table 1

Insulation resistance test between windings of a DC machine

Date	Time	Weather condition	Duty cycle	Test between terminals	Insulation resistance in megohms	Remarks
1	2	3	4	5	6	7
				Armature and shunt field		
				Shunt and series field		
				Series field and armature		

TASK 3: Test a DC machine for insulation resistance between armature/winding and body

- 1 Fill up the columns 1 to 4 in Table 2.
- 2 Connect the Megger between the armature and body (Fig 3a) and repeat step 3 of Task 2, and note down the reading in Table 2.
- 3 Connect the Megger between the series winding and body (Fig 3b) and repeat step 3 of Task 2, and note down the reading in Table 2.
- 4 Connect the Megger between the shunt winding and body (Fig 3c) and repeat step 3 of Task 2, and note down the reading in Table 2.

If any reading is zero ohms, it shows a short circuit of that winding to the body.

If the reading is less than one megohm, it shows that the insulation is weak. If the value is less than one megohm, inform your instructor immediately so that the necessary remedial steps could be taken to improve the insulation resistance.

- 5 Show the results to your instructor and get his approval.

Fig 3

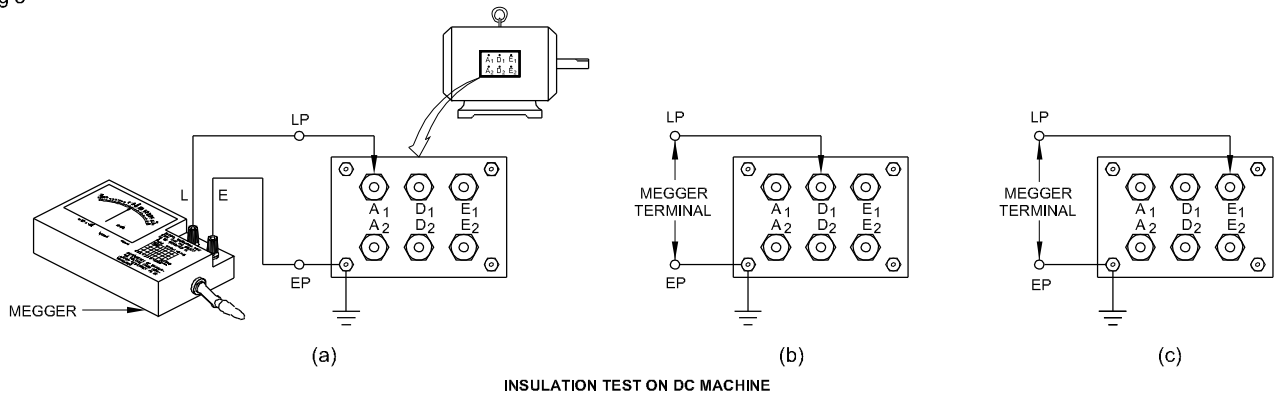

ELN3118H3

Table 2

Insulation resistance test between armature/field windings and the body of a DC machine

Date	Time	Weather condition	Duty cycle	Test between terminals	Insulation resistance in megohms	Remarks
1	2	3	4	5	6	7
				Armature and the body		
				Series field and the body		
				Shunt field and the body		

Copyright © NIMI
Not to be Republished

Start, run and reverse direction of rotation of DC series, shunt and compound motors

Note : Exercise 3.1.119 is related to DC Motor and thus placed after the Exercise 3.2.127

Copyright @ NIMI
Not to be Republished

Perform no load and load test and determine characteristics of series and shunt generators

Objectives: At the end of this exercise you shall be able to

- test and identify the terminals of DC series generator
- conduct no load test of a DC series generator
- conduct load test and characteristics of a series generator
- conduct no load test of a DC shunt generator
- perform load test and characteristic of the shunt generator.

Requirements	
<p>Tools/Instruments</p> <ul style="list-style-type: none"> • Combination pliers 200mm - 1 No. • Screw driver 150 mm - 1 No. • Electricians knife 100mm - 1 No. • Revolution counter 4 digits - 1 No. • Stop watch - 1 No. • M.C ammeter 0 to 5A 250V - 1 No. • M.C voltmeter 0-300V - 1 No. • M.C ammeter 15A 250V - 1 No. 	<p>Equipment/Machines</p> <ul style="list-style-type: none"> • DC series generator 2 or 4 KW 220V - 1 No. • DC shunt generator 2 or 4KW 220V - 1 No. • Rheostat 480Ω 1A - 1 No. • Knife switch DPST 20A/250V - 1 No. • Knife switch SPST 16A/250V - 1 No. • Lamp load 220V/5KW - 1 No. <p>Materials</p> <ul style="list-style-type: none"> • P.V.C. Insulated cable 2.5 sq.mm - 6 m • Fuse wire 16A - 0.5m • P.V.C Insulated flexible cable 14/0.2 - 2 m

PROCEDURE

TASK 1: Conduct no load test of a DC series generator

- 1 Place all the materials and tools on the work bench.
- 2 Read and interpret the name plate details of the given generator.
- 3 Identify the terminals of the given DC series generator.

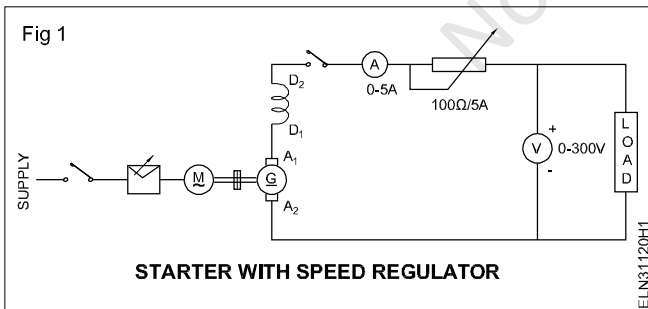

- 4 Connect the circuit as per Fig 1.
- 5 Start the generator and note down readings.

- 6 Measure the speed of the generator with the help of the revolution counter and stop watch.
- 7 Adjust the prime mover speed such that the generator runs at its rated speed.
- 8 Measure the voltage induced across the armature and note down the measured value in Table 1.
- 9 Increase the field current slowly in steps of 0.1 amperes and for each step note down the field current and the corresponding induced voltage and record them in Table 1.
- 10 Switch off the DC generator and the prime mover.
- 11 Draw the graph keeping the induced voltage in the 'Y' axis and the field current in the x axis.
- 12 Show your readings and graph to your Instructor.

Table 1

Sl. No.	Field current in amps	Induced voltage in volts	Speed (held at constant rated value throughout the experiment)
1			
2			
3			
4			
5			

TASK 2 : Conduct load test and analyse characteristics of DC series generator

- Place all the materials and tools on the work bench.
- Connect the circuit as per Fig 2.
- Plot the graph between terminal voltage and load current.(Fig 3)

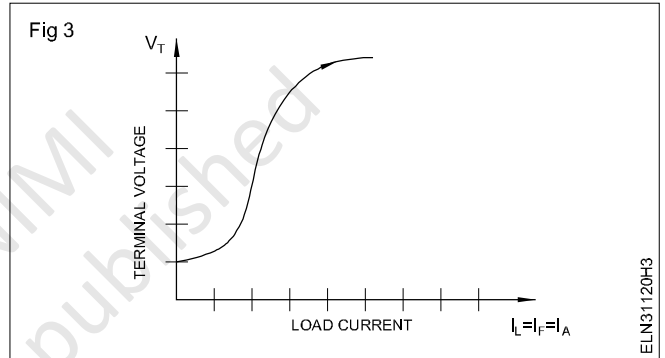
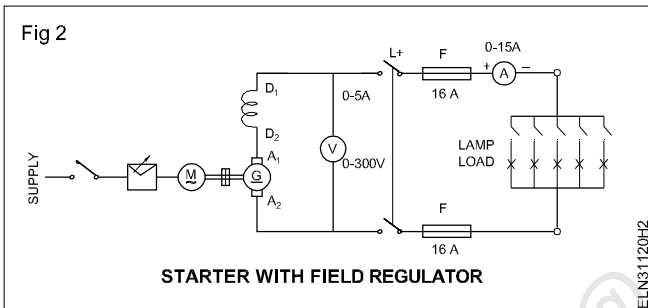

- Keep the main switch at off position.
- Rotate the armature using a prime mover at the rated speed.
- Operate the main switch in ON position.
- Now operate the load switch in ON position
- Note down the ammeter and voltmeter readings in the Table 2.
- Change the speed of generator and note the different values of ammeter and voltmeter

Table 2

Sl No	Load current I_L (in amps)	Terminal Voltage V_T (involts)
1		
2		
3		
4		
5		

TASK 3: Perform conduct no load test of a shunt generator

- Read and interpret the name-plate details of the given DC shunt generator and record them in Table 1. (As given in exercise 3.1.116)
- Identify the terminals of the given DC shunt generator.
- Connect the circuit as per Fig 4.
- Keep the field switch open and the field rheostat in the cut 'in' position. Get the approval of the instructor.
- Start the prime mover coupled to the DC shunt generator.

The direction of rotation must be according to the direction marked on the DC generator. If not, change the direction of the rotation of the prime mover.

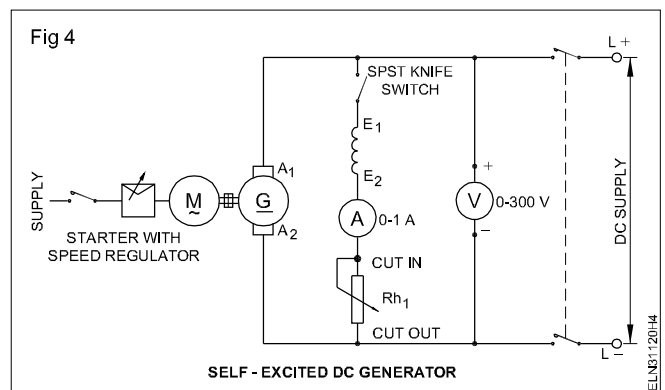

6 Measure the speed of the generator with the help of the revolution counter and stopwatch.

The number of revolutions made by a machine in a minute gives the r.p.m.

7 Adjust the prime mover speed such that the generator runs at its rated speed.

Keep the speed constant throughout the experiment.

8 Measure the voltage induced across the armature and note down the measured value in Table 3.

This induced voltage is due to the residual magnetism as the field current is zero. If the residual magnetism is absent in the field poles, then there will be no residual voltage. In such a case the residual magnetism could be recreated by connecting the field winding to a DC source such as a battery for a short time.

9 Close the field circuit switch and gradually increase the field current to 0.1 ampere by reducing the resistance of the field rheostat.

If the generator is not able to build up voltage even though it is running in the marked direction, switch off the prime mover and then interchange the field terminals of the generator. While varying the field rheostat/regulator it should be done positively and slowly in the forward direction. Reverse movement should be avoided.

10 Increase the field current slowly in steps of 0.1 ampere, and for each step, note down the field current and the corresponding induced voltage. Record them in Table 3.

Increase the field current only till the induced voltage reaches just above 125% of the rated value. Check the speed of the generator at intervals. If necessary, adjust it to the rated value.

11 Switch 'OFF' the DC generator and the prime mover.

12 Draw the graph keeping the induced voltage in the 'Y' axis and the field current in the X axis.

The graph shows the magnetisation / no-load characteristic of the DC shunt generator.

13 Show your readings and graph to your instructor.

14 Answer the following questions.

a The magnitude of the residual voltage is

b When there is no current in the field, how is the residual magnetism available in the poles?

c What are the reasons for the disappearance of residual magnetism in a DC generator?

d What is the reason for the magnetisation characteristic curve to have a straight line relationship between the field current and the induced voltage?

e What is the reason for the magnetisation characteristic curve to have a flat portion in the end?

f Could you remember the shape of the magnetisation characteristic as a part of a certain other curve which you studied earlier? If yes, write where and how the two curves are related to each other.

Table 3

Sl.No.	Field current in amps	Induced voltage in volts	Speed (held at constant rated value throughout the experiment)

TASK 4: Conduct load test and analyse characteristics of a DC shunt generator

- 1 Read and interpret the name-plate details of the DC shunt generator and record them in Table 1. (As given in exercise 3.1.116)
- 2 Identify the terminal of the given DC shunt generator.
- 3 Measure the armature resistance and enter the value in Table 4.
- 4 Select appropriate cables, switch, load and meters, according to the capacity of the given DC shunt generator.
- 5 Connect the meters, rheostat and lamp load with the terminals of the DC shunt generator. (Fig 5a) (If a lamp load is not available, a water load (Fig 5b) can be used.)
- 6 Keep the load switch open and also switch 'off' all the circuit switches in the lamp load.
- 7 Keep the field regulator resistance in 'cut-in' position.

Make yourself clear about the method of starting the prime mover and the procedure of adjusting its speed.

- 8 Start the prime mover and bring it to the rated speed of the generator.
- 9 Build up the voltage of the generator to its rated value, by adjusting the field rheostat. Enter the value of the open circuit voltage in Table 3.

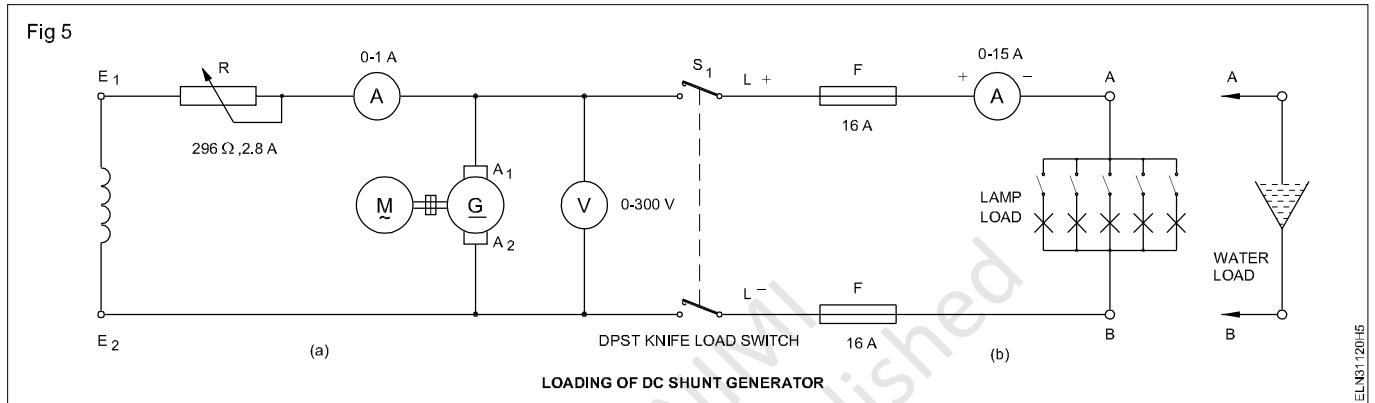

Table 4

Sl.No.	Terminal voltage `V'(Volts)	Load current I_L	Shunt field current (I_{sh}) kept constant	Armature current $I_a = I_L + I_{sh}$	Induced emf $E = V + I_a R_a$	Remarks
						Armature resistance = ohms

Remember

Open circuit voltage $V = E - I_a \cdot R_a$
 where E is the induced emf
 I_a is the armature current
 R_a is the armature resistance.

The armature current $I_a = I_L + I_{sh}$
 where I_L is the load current
 I_{sh} is the field current.

In the case of no load $I_L = 0$
 hence $I_a = I_{sh}$.
 Therefore, at no load, the terminal voltage comes to
 $V = E - (0 + I_{sh}) \cdot R_a$.

- 10 Close the load switch and gradually load the generator by switching 'ON' a few lamps.
- 11 Read the corresponding terminal voltage, shunt field current, load current, and record them in Table 4.

Check the speed of the generator at intervals, and adjust it to the rated value.

- 12 Increase the load current up to 125% of its rated value in 6 or 8 equal steps.
- 13 Note down the corresponding terminal voltage and field current for each step of load current in Table 4.
- 14 Gradually reduce the load current to zero and switch 'OFF' the load circuit and the prime mover.

- 15 Show the record of your readings to the instructor and get his approval.
- 16 Draw the graph of the external characteristic of a DC shunt generator by keeping the terminal voltage in the Y-axis and the load current in the X-axis. (Fig 6)
- 17 Show the graph to your instructor and get his approval.
- 18 Disconnect the circuit.

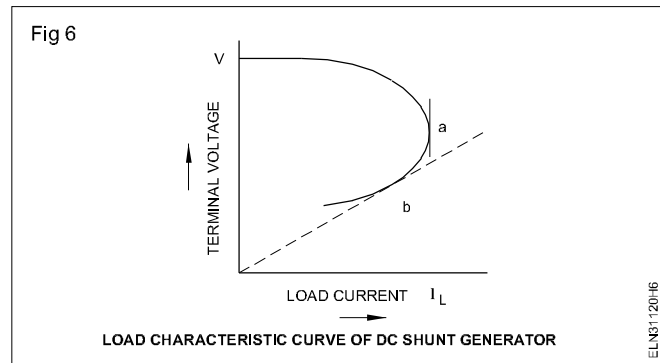

Copyright @ NIMI
Not to be Republished

Perform no load and load test and determine characteristics of compound generators (cumulative and differential)

Objectives: At the end of this exercise you shall be able to

- connect the DC compound generator as long shunt and then as short shunt
- build up voltage and load the compound generator
- determine the load performance characteristic of a DC compound generator (cumulative and differential).

Requirements			
Tools/Instruments		Equipment/Machines	
• Combination pliers 200mm	- 1 No.	• DC compound generator 220V 4KW	- 1 No.
• M.C. voltmeter 0-250V	- 1 No.	• Lamp load/resistance load/water load of capacity 220V 5KW	- 1 No.
• Screwdriver 150mm	- 1 No.		
• M.C. ammeter 0-20A	- 1 No.	Materials	
• Electrician's knife	- 1 No.	• PVC Insulated copper cable 4 sq mm	- 5 m
• Rheostat 296 ohms 2.8 amp	- 1 No.	• DPST knife switch 16A 240V	- 1 No.

PROCEDURE

TASK 1: Connect, build up and determine the load performance characteristic of a DC long shunt compound generator : (a) cumulative (b) differential.

- 1 Read and interpret the name-plate details of the given DC compound generator and record them in Table 1. (As given in exercise 3.1.116)
- 2 Select meters, rheostat and cables according to the rating of the available DC compound generator.

Rating of meters, rheostat and cables given in this exercise, are for 4kW 220V DC compound generator. If any other rating machine is given, you have to select meters of appropriate ranges and cables of proper ratings.

- 3 Identify the terminals of the DC compound generator either from the marking or by testing.
- 4 Connect the machine as per the connection diagram. (Fig 1)

To check whether the compound generator is connected for cumulatively compound or differentially compound which will not be easy at this stage. But this could be determined after loading.

- 5 Provide a suitable fuse according to the rating of the DC compound generator.

Keep the load switch and all the load sub-circuit switches open.
Keep the field rheostat sliding arm in such a position that the maximum value of resistance is included in the field circuit.

- 6 Start the prime mover coupled to the DC compound generator, and build up the voltage of the DC compound generator to its rated value.
- 7 Switch 'ON' the load.
- 8 Increase the load step by step, note the values of the terminal voltage and load current for each step, and enter them in Table 1.

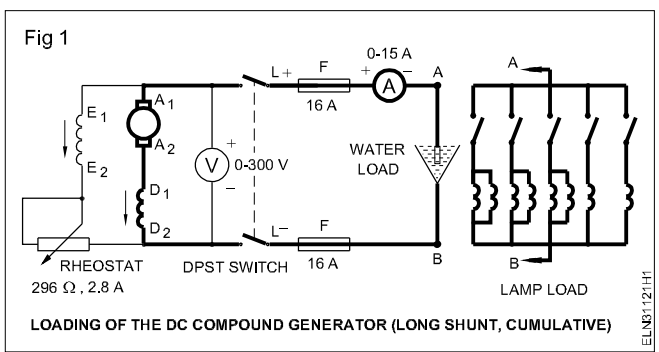

Table 1
Long shunt compound generator

I EXERCISE			II EXERCISE		
SI.No	Load current	TPD	SI.No	Load current	TPD
Type of connection			Type of connection		

9 Draw the external characteristic curve keeping the load current in the 'X'-axis and the terminal voltage of the generator in the 'Y'-axis.

Check whether the terminal voltage falls or rises with the increased load. If the terminal voltage falls heavily, the internal connection is for a differentially compound generator. If it rises or falls slowly, it is for a cumulatively compound generator. Sometimes the terminal voltage will remain constant from no load to full load. This type of generator is called a level compound generator, and it comes under the category of cumulatively compound generators.

To change the generator from one type to the other, either the shunt or the series field terminals have to be changed. Fig 2 shows the connection diagram of the compound machine after changing the series field terminals whereas the initial connection is shown in Fig 1.

- Open the load switch and stop the prime mover.
- Interchange the connections of the series field. (Fig 2)

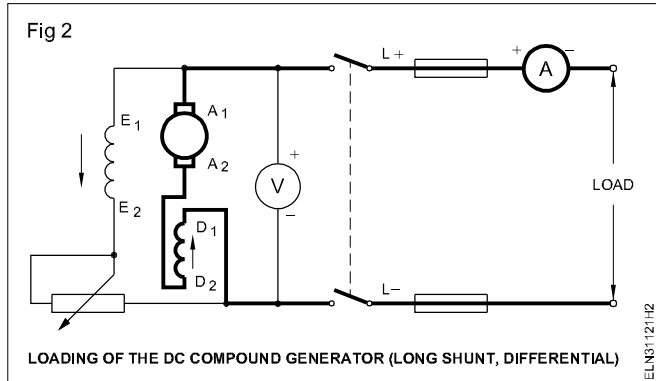

- Repeat the working steps 6 to 9 and draw the external characteristic curve for the second set of readings in the same graph sheet.
- Write clearly which one of the graph is for the cumulatively compounded generator, and which one is for the differentially compounded generator.

TASK 2: Determine the load performance of DC short shunt compound generator : a) Cumulative b) Differential

1 Check connections (Figs 1 & 2) are for a long shunt compound generator.

Complete the connection diagrams shown in Figs 3a and 3b for the short shunt cumulative, and differential compound generator, and get it approved by the instructor.

- Repeat the experiment for the short shunt cumulative and differential compound generators following steps 5 to 13 of Task 1, and enter the values in Table 2.
- Draw the external characteristic curves on a separate graph sheet in the same scale as in the earlier graphs, and compare with them.

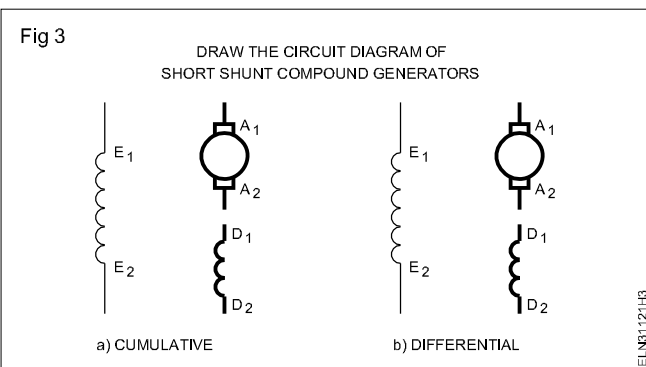

(ASSUMPTION: The internal connections tally with the diagrams given in Figs 1 and 2.)

Table 2

Short shunt compound generator

I EXERCISE			II EXERCISE		
SI.No	Load current (Amps)	TPD Volt	SI.No	Load current (Amps)	TPD volt
1					
2					
3					
4					
Type of connection			Type of connection		

Practice dismantling and assembling in DC shunt motor

Note : Exercise 3.1.122 is related to DC Motor and thus placed after the Exercise 3.2.128.

Copyright @ NIMI
Not to be Republished

Practice dismantling and assembling in DC compound generator

Objectives: At the end of this exercise you shall be able to

- read and interpret the name-plate details of a DC compound generator
- conduct visual inspection of the electrical machine
- dismantle the DC compound generator
- remove, inspect and install the bearings
- clean the parts of the DC generator
- reassemble the DC compound generator
- adjust the brush tension and bedding of brushes and correct the rocker arm position
- check the performance of DC compound generator.

Requirements

Tools/Instruments

- Pulley puller 6" - 1 No.
- Hammer 500 gms - 1 No.
- Cutting pliers 200mm - 1 No.
- Centre punch 100mm. length - 1 No.
- Spanner set 5mm to 20mm - 1 set
- Screwdriver, heavy duty - 200 mm
- Tray 300 x 300 mm - 1 No.
- Mallet, hardwood 60mm dia. - 1 No.
- "Man on line" board - 1 No.
- Electric blower 240V 50HZ - 1 No.

Equipment/Machines

- DC compound generator - 1 No.

Materials

- Kerosene - 1 litre
- Cotton cloth - 1/4 sq. m.
- Carbon tetrachloride - 100 ml.
- Round brush for cleaning 2cm - 1 No.
- Petrol - 200 ml.
- Sandpaper No.1 - 1 sheet
- Hacksaw blade 300 mm - 3 Nos.
- Sandpaper `oo' smooth - 1 sheet
- Mobile oil S.A 40 - 1/2 litre
- Cotton waste - 100 gms
- Shell alvania 3 grease or equivalent - 100 gms
- Hardwood 3cm sq. 20cm long - 2 pieces

PROCEDURE

TASK 1: Dismantle, inspect and reassemble DC compound generator

- 1 Read the manufacturer's instruction booklet, and particularly take into account any special instructions regarding dismantling procedures.
- 2 Remove the fuse-carriers from the main switch, disconnect the DC machine from the supply and display the "Man-on-line board" on the main switch.
- 3 Remove the foundation bolts of the machine and shift the machine to the workbench.
- 4 Conduct a visual inspection.
- 5 Clean the outside surface of the motor. Remove all dirt and grease with a dry cloth soaked in petrol/kerosene.

Do not use water.

- 6 Make punch marks on both the end plates and yoke. (Fig 1)
- 7 Mark the rocker arm position with respect to the end plate.
- 8 Remove the brushes from the brush-holder. (Fig 2)

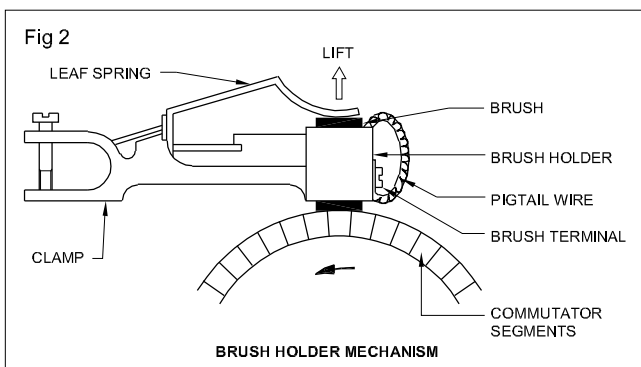
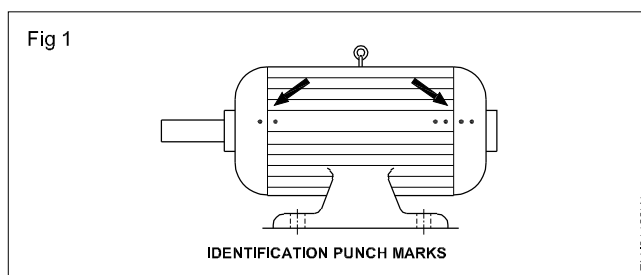

9 Check pulley tight and adjust. (Fig 3).

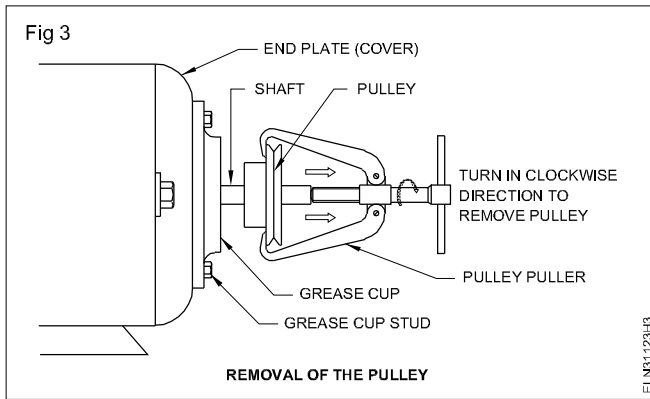

10 Remove the grease cup stud and open the grease cup. (Fig 4)

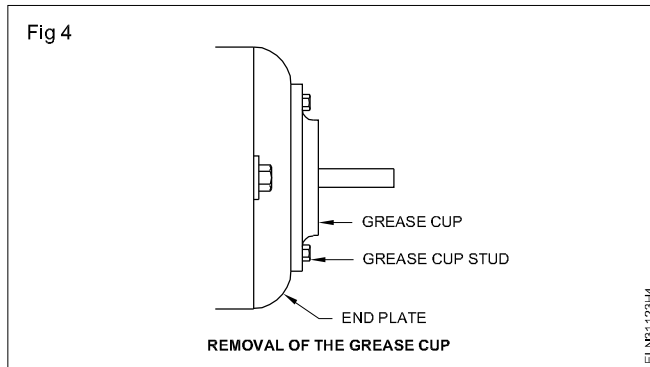

11 Loosen the studs of both the end plates and then remove the end plate of the shaft side.

Open one end of the end plate slowly by holding the armature shaft by hand or pulley block so that the weight of the armature does not damage the pole faces or field windings.

12 Remove the armature from the body of the machine. (Fig 5)

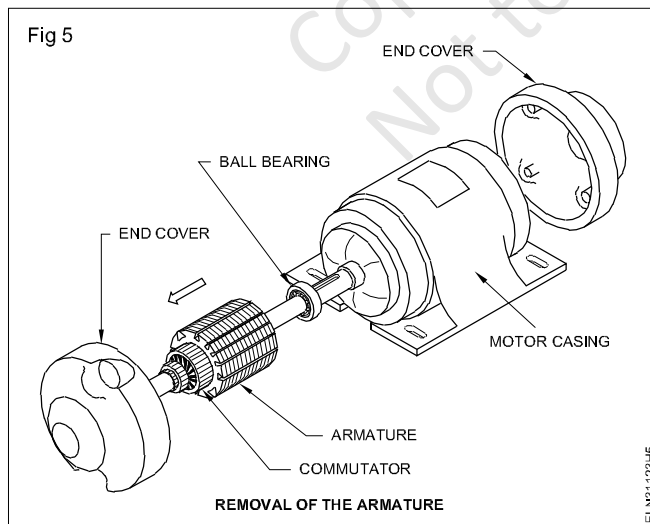

13 Remove the bearings using a bearing puller (Fig 6).

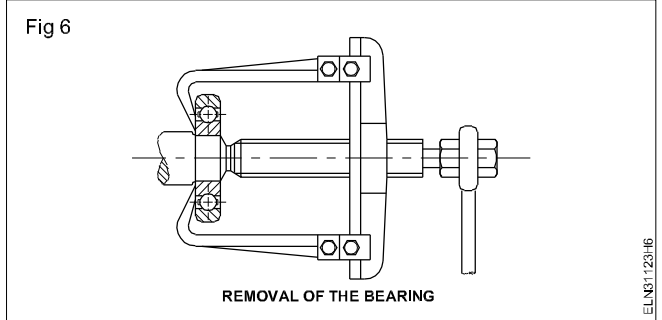

14 Reassemble the yoke, armature and end plates.

15 Check the freeness of the shaft by rotating the shaft by hand.

If found tight (not free) loosen the end-plate studs and tighten the crosswise studs gradually in the proper sequence, and at the same time feeling the shaft for free rotation.

16 Insert the brush in the holder, adjust the brush tension, and bed the brushes.

17 Position the rocker-arm in the end plates as per original marking.

18 Re-install the machine in the foundation and tighten the foundation bolts and connect the generator.

19 Check whether the generator is operating smoothly without any vibration. A check-list for mechanical functions is given in Table 1. Fill up all the possible columns after checking the generator operation.

Table 1

Sl. No.	Check-list (Mechanical)	Remarks
1	Noise	
2	End-play	
3	Rotor running free	
4	Bearing fits	
5	Lubrication, grease, nipples oil supply	
6	Temperature bearings	
7	Temperature motor frame	
8	Condition of shaft, keyway, pulley, bearing seals	
9	Bolts, nuts tightened	
10	Test run 30 min	

Conduct performance analysis of DC series shunt and compound motors

Objectives: At the end of this exercise you shall be able to

- read and interpret the name-plate details of a DC series motor
- test and identify the terminals of a DC series motor
- measure the armature resistance
- measure the series field resistance
- connect the two-point starter for series and 3 point & 4 point starter for shunt and compound motor
- measure the speed of the motors
- vary the load of a DC series motor
- determine the performance characteristic of a DC series motor shunt motor and compound motor and draw the following curves
 - speed versus load
 - torque versus load
 - speed versus torque.
- determine the efficiency of the DC shunt motor at different loads.

Requirements

Tools/Instruments

- Insulated cutting pliers 150mm - 1 No.
- Screwdriver 150mm - 1 No.
- D.E. spanner set 5mm to 20mm - 1 No.
- 500V Megger - 1 No.
- Multimeter/ohmmeter 0 to 2 K ohms - 1 No.
- M.C.ammeter 0-15A - 1 No.
- M.C. volmeter 0-300V - 1 No.
- Tachometer 300-3000 r.p.m - 1 No.

Equipment/Machines

- D.C. series motor 220V 3 H.P - 1 No.
- ICDP switch 250V 16A - 1 No.
- 2- Point starter - 1 No.
- Dial type spring balance 25kg capacity - 1 No.

- Prony brake system complete - 1 No.
- DC shunt motor 220V 2/3 HP - 1 No.
- 220V 4 - point starter - 1 No.
- Rheostat 100 ohms 2 amps - 1 No.
- Brake test arrangement with two spring balances of 25 and 50 kg rating - 1 Set
- 220V DC compound motor 2 or 3 with prony brake loading arrangement - 1 Set

Materials

- 2.5 sqmm PVC insulated multi-strand copper cable - 6 m.
- Fuse wire 5A &10A. - as reqd.
- Test lamp - 1 No.

PROCEDURE

TASK 1: Conduct the load performance test on a DC series motor

- 1 Note down the name-plate details.
- 2 Identify the terminals of the given DC series motor and test for insulation and ground.
- 3 Select and collect the required equipment, apparatus and cables, and connect the motor as per the circuit diagram. (Fig 1)

The DC series motor should not be started or made to run without load.

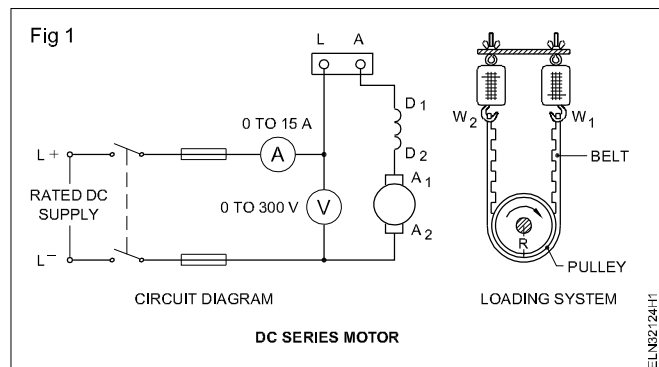

- 4 Start the DC series motor slowly by moving the starter handle to the 'ON' position.
- 5 Check the speed, load current and input voltage. Adjust the load current to 1/4th of the F.L. value by adjusting the load.
- 6 Measure the speed, load current, voltage and read the spring balance and record in Table 1.
- 7 Slowly increase the load in steps up to full load. Record the measurement for 1/2, 3/4 and full load.
- 8 Tabulate all the readings in the tabular columns provided in Table 1.
- 9 Stop the motor by switching it off after taking all the readings.

- 10 Measure the radius of the pulley and calculate the torque, horsepower and efficiency.
- 11 Draw the following characteristic curves.
 - Speed versus load
 - Torque versus load
 - Speed versus torque
- 12 Write your conclusion about the relationship between speed and load, torque and load, speed and torque and efficiency and load.

CONCLUSION

Do not remove the mechanical load before switching off.

Table 1

Sl. No.	Load	Applied voltage (volts)	Line current (amps)	Spring balance		Radius of pulley (metre)	T ₁ Torque in Kilogram metre	T Torque in N.M NM= 1 kg mx9.81	N Speed in r.p.m.	OP = $\frac{(2\pi NT)}{60}$ (where N is the speed in r.p.m. & T is the torque in newton metre)	Efficiency = $\frac{(OP \times 100)}{IP}$
				W ₁ kg	W ₂ kg						
	1/2 3/4 Full load										

TASK 2: Conduct the load performance test on a DC shunt motor

- 1 Read and interpret the name-plate details and record it.
- 2 Switch 'OFF' the mains and remove the fuses.
- 3 Determine the terminals of the DC shunt motor.
- 4 Test the shunt motor for continuity, short circuit and insulation resistance between
 - the windings
 - the windings and the earth.
- 5 Select a proper rating of I.C.D.P. switch, cables, fuse wire and 4-point starter according to the rating of the given DC shunt motor.

- 6 Connect the DC shunt motor as per the circuit diagram.(Fig 2) Keep the shunt regulator rheostat in the cut out position, and the mechanical load applied through the brake to zero value.

The rating given here for the switch, fuse, cable and 4- point starter is for 220 V, 3 HP motor only.

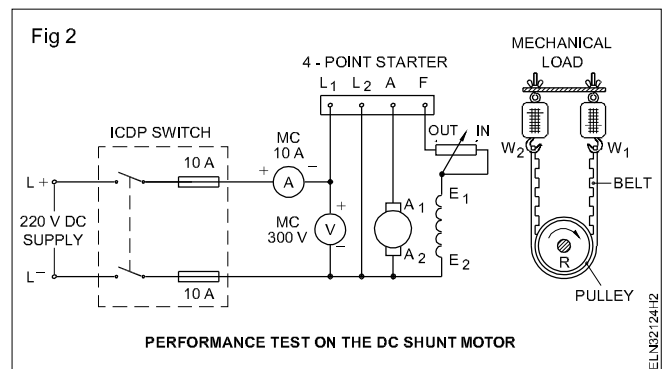

TASK 3: Determine the relation between load current, speed and torque

- 1 Switch on and move the 4-point starter handle, gradually up to 'ON' position.
- 2 Measure the speed, and if necessary, adjust the speed to the rated value by adjusting the shunt regulator rheostat and note down the reading in Table 2.
- 3 Increase the load step by step by tightening the wing-nut.
- 4 Measure the speed each step read the meters and the spring balances and record them in Table 2. Load the motor up to its full load value.
- 5 Reduce the load gradually and switch 'OFF' the motor.
- 6 Measure the radius of the pulley in metres and calculate the torque in kg. metres.

- 10 Write the conclusion by highlighting the relation between
 - speed and load
 - torque and load
 - torque and speed.

Torque in kg.m = (W₁ – W₂)kg x radius of pulley in meters where W₁ is the reading of the tight side spring balance and W₂ is the reading of the slack side of the spring balance in kilograms.

- 7 Draw the speed load characteristic curve, keeping the load (line) current in the X-axis and the speed in the Y-axis.
- 8 Draw the torque-load characteristic in the same graph sheet, keeping the load (line) current in the X-axis and torque in the Y-axis.
- 9 Draw the torque-speed characteristic in the same graph sheet, keeping the torque in the X-axis and the speed in the Y-axis.

Use different colours for each curve.

- 11 Calculate the efficiency of the given DC shunt motor by applying the following formula and record it in Table 2.

$$\text{Output} = \frac{2\pi NT}{60} \text{ newton metres/sec. or watts}$$

where N is the speed in r.p.m.

T is the torque in newton metres.

(To convert the torque in Kg metre to newton metre multiply Kg M by 9.81.)

$$\text{Input} = VI$$

where V is the applied voltage, I is the line current.

$$\text{Hence efficiency} = \frac{\text{output}}{\text{input}} \times 100$$

$$= \frac{2\pi NT \times 100}{60 \times VI} \text{ percentage.}$$

Table 2

Sl. No.	Applied voltage (volts)	Line current (amps)	Spring balance		Radius of pulley (metre)	T ₁ Torque in Kilogram metre	T Torque in N.M NM= 1 kg mx9.81	N Speed in r.p.m.	OP = $\frac{(2\pi NT)}{60}$ (where N is the speed in r.p.m. & T is the torque in newton metre)	Efficiency = $\frac{(OP \times 100)}{IP}$
			W ₁ (kg)	W ₂ (kg)						

TASK 4: Conduct the load performance test of a DC compound motor

a Identify the terminals and test the condition of the DC compound motor

- 1 Identify the terminals of the given DC compound motor.
- 2 Test the given DC compound motor for continuity, insulation and ground faults, and make sure the machine is in good condition.
- 3 Select suitable size of cables, I.C.D.P switch and loading arrangements, according to the machine rating.

The rating of the switch, fuse cable and 4-point starter should be changed according to the rating of the given DC compound motor.

b Connect the machine as a long shunt cumulative compound motor and test it for its performance

- 1 Connect the machine as a long shunt (cumulative) compound motor with the switches, fuses and meters and starter.(Fig 3)

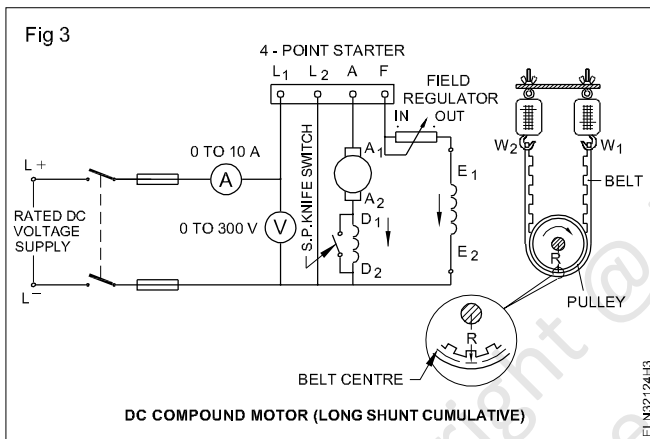

- 2 Arrange the prony brake for loading the motor.
- 3 Keep the series field shorted by the S.P.S.T. knife switch.

This will enable the motor to start normally, even if it is connected as a differential compound motor.

- 4 Keep the field regulator in the 'cut out' position. Switch on the supply and move the 4-point starter handle gradually up to the 'ON' position.
- 5 Open the series field shorting switch.
- 6 Measure the speed and adjust it to the rated value and note down the readings in Table 3.
- 7 Increase the load step by step up to the full load following the instructions contained in step 8.

When applying the load, the speed may increase, if it is differential. Then stop the motor and interchange the connections of the series field for cumulative compounding. Accordingly modify the connection diagram. (Fig 3)

- 8 Measure the speed for each step read the meters and spring balances and record them in Table 3. Increase the load up to the full load value.

- 9 Reduce the load gradually, switch off the motor.

- 10 Measure the pulley radius for calculating the torque.

The torque = $(W_1 - W_2)$ in Kgs x radius in meters,

$T = \text{Kg metre}$, where W_1 is the tight side spring balance reading and W_2 is the slack side spring balance reading in kgs.

- 11 Calculate the torque in newton-metre = Kg. metre x 9.81.

- 12 Calculate the input = $V \times I$ in watts.

Calculate the output = $\frac{(2\pi NT)}{60}$ NW – metres or watts.

Calculate the percentage efficiency using the formula

$$= \frac{(OP \times 100)}{IP} = \frac{2\pi NT}{60 \times VI} \times 100 \text{ percent.}$$

- 13 Enter the values of efficiency for various load currents in Table 3.

- 14 Draw the speed-load characteristic curve keeping the load current in the X-axis and speed in the Y-axis.

- 15 Draw the torque-load characteristic in the same graph sheet, keeping the load current in the X-axis and the torque in the Y-axis. Use different colours.

- 16 Draw the torque-speed characteristic in the same graph sheet, using a different colour and keeping the torque in the X-axis, and the speed in the Y-axis.

- 17 Write your conclusion by highlighting the relation between – speed vs load

- torque vs load
- speed vs torque.

CONCLUSION

- 18 Draw the curve showing the relation between load and efficiency of the DC compound motor in a separate graph sheet keeping the load in the 'X' axis and the efficiency in the 'Y' axis.

Table 3

Sl. No.	Applied voltage (volts)	Line current (amps)	Spring balance		Radius of pulley (metre)	T ₁ Torque in Kilogram metre	T Torque in N.M NM= 1 kg mx9.81	N Speed in r.p.m.	OP= $\frac{(2\pi NT)}{60}$ (where N is the speed in r.p.m. & T is the torque in newton metre)	Efficiency = (OP x 100) / IP
			W ₁ (kg)	W ₂ (kg)						
1										
2										
3										
4										
5										

c Connect the machine as a long shunt differential compound motor and test it for its performance.

Tasks c to e to be carried out by the trainees under the direct supervision of the instructor.

- 1 Complete the circuit (Fig 4) for the long shunt differential compound motor and get the approval of your instructor.
- 2 Connect the machine as a long shunt, differential compound motor with the switches, meters and starter as per the approved diagram. (Fig 4)
- 3 Repeat the steps 2 to 7 of Task 4 b and enter the readings in Table 4.

If the connections are correct, the speed may increase with the increased load.

- 4 Repeat the steps 8 to 18 of Task 4b, and write the conclusions.

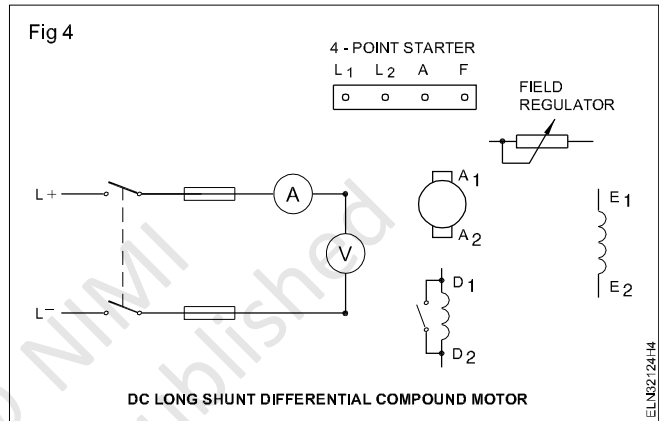

Conclusion

Table 4

Sl.No.	Applied voltage (volts)	Line current (amps)	Spring balance		Radius of pulley (metre)	T ₁ Torque in Kilogram metre	T Torque in N.M NM= 1 kg mx9.81	N Speed in r.p.m.	OP= $\frac{(2\pi NT)}{60}$ (where N is the speed in r.p.m. & T is the torque in newton metre)	Efficiency = (OP x 100) / IP
			W ₁ (kg)	W ₂ (kg)						
1										
2										
3										
4										
5										
6										

d Connect the machine as a short shunt, cumulative compound motor and test it for its performance.

- 1 Complete the circuit given in Fig 5 for the short shunt, cumulative compound motor and get the approval of your instructor.
- 2 Connect the machine as a short shunt cumulative compound motor as per the approved diagram. (Fig 5)
- 3 Repeat the steps 2 to 7 of Task 4 b and enter the readings in Table 5.

If the connections are correct, the speed may fall or remain constant at the increased load.

- 4 Repeat the steps 8 to 18 of Task b, and write the conclusions.

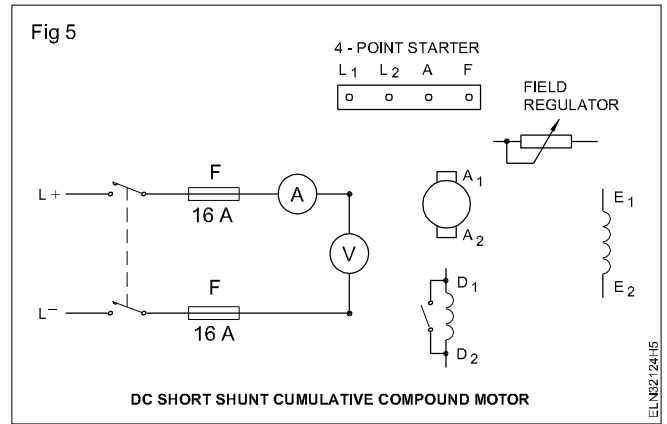

Conclusion

Table 5

Sl.No.	Applied voltage (volts)	Line current (amps)	Spring balance		Radius of pulley (metre)	T ₁ Torque in Kilogram metre	T Torque in N.M NM= 1 kg mx9.81	N Speed in r.p.m.	OP= $\frac{2\pi NT}{60}$ (where N is the speed in r.p.m. & T is the torque in newton metre)	Efficiency = (OP x 100) / IP
			W ₁ (kg)	W ₂ (kg)						
1										
2										
3										
4										
5										

e Connect the machine as a short shunt, differential compound motor and test it for its performance

- 5 Complete the circuit (Fig 6) for the short shunt differential compound motor and get the approval of your instructor.
- 6 Connect the machine as a short shunt differential compound motor as per the approved diagram. (Fig 6)
- 7 Repeat the steps 2 to 7 of Task 4b and enter the reading in Table 6.

If the connections are correct the speed will increase at the increased load.

- 8 Repeat the steps 8 to 18 of Task 4, and write the conclusions.

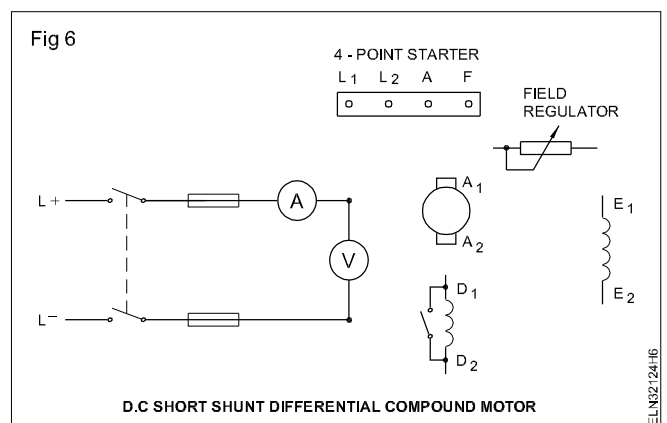

Conclusion

Table 6

Sl.No.	Applied voltage (volts)	Line current (amps)	Spring balance		Radius of pulley (metre)	T ₁ Torque in Kilogram metre	T Torque in N.M NM= 1 kg mx9.81	N Speed in r.p.m.	OP= $\frac{(2\pi NT)}{60}$ (where N is the speed in r.p.m. & T is the torque in newton metre)	Efficiency = (OP x 100) / IP
			W ₁ (kg)	W ₂ (kg)						
1										
2										
3										
4										
5										

Copyright @ NIMI
Not to be Republished

Dismantle and identify parts of three point and four point - DC motor starters

Objectives : At the end of this exercise you shall be able to

- **dismantle the 3 points & 4 point starter**
- **identify the parts of three point starter**
- **identify the parts of four point starter.**

Requirements			
Tools/Instruments		Materials	
• Combination pliers 200mm	- 1 No.	• PVC Insulated stranded	
• Screw driver 200mm	- 1 No.	• Copper cable 4 sq mm	- 10 m
• Multimeter	- 1 No.	• DPST main switch	- 1 No.
Equipment/machines		• Insulated tape	- 0.2m
• 3 point starter 3HP 240V	- 1 No.	• Fuse wire of required amps	- as reqd.
• 4 point starter 3Hp 240V	- 1 No.		
• Series testing board	- 1 No.		

PROCEDURE

TASK 1: Identify the parts and terminals of 3 point starter

1 Write down the name plate details of the given DC 3 point in Table 1.

Table 1

DC starter	_____	3point
Volts	_____	
Amps	_____	
Serial No.	_____	
Make	_____	

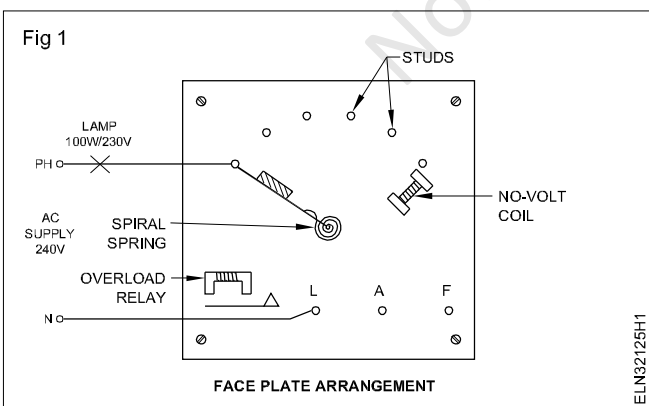

- 2 Identify the different parts of the starter and draw the starter diagram and label the parts in your record.
- 3 Connect one lead of series testing board with the 'handle' of the starter and connect second lead with the

other terminals of the starter. Keep checking the other terminals with the second lead till the lamp glows. When the lamp glows brightly with any one of the terminals, that shows terminal is 'L' (Fig 1).

- 4 Connect one lead of the series testing board with any stud of the resistance and another one with remaining two terminals respectively. The terminal on which the lamp glows dim is terminal 'F'. Connect the remaining third terminal and check lamp glow bright. (Fig 2)

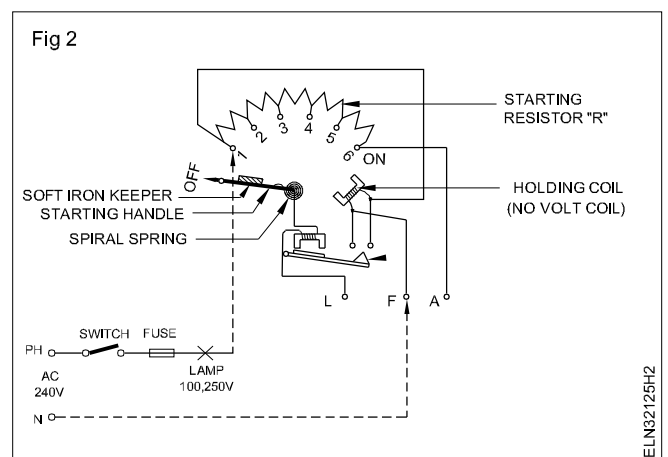

**Testing should be done carefully.
While identifying terminals, power supply should not be switched ON in the starter.**

TASK 2 : Identify the parts and terminals of 4 point starter

- 1 Write down the name plate details of given DC 4 point starter in Table 2.

Table 2

DC starter	_____	4point
Volts	_____	
Amps	_____	
Serial No.	_____	
Make	_____	

- 2 Identify the different parts of the starter and draw the starter diagram and label the parts in your record.
- 3 Connect one lead of series testing board with the 'handle' of the starter and connect second lead with the other terminals of the starter. Keep checking the other terminals with the second lead till the lamp glows. When the lamp glows brightly with any one of the terminals, that shows terminal is 'L₁' (Fig 3).
- 4 Connect one lead of the series testing board with any stud of the resistance and another one of the three terminals respectively. The terminal on which lamp glows more dim (or) spark on the terminals, that shows terminal is L₂. (Fig 4)
- 5 Connect one lead of the series testing board with any stud of the resistance and another one with remaining two terminals respectively. The terminal on which the lamp glows more bright is terminal 'F'.
- 6 The remaining fourth terminal is that of the terminal 'A'.

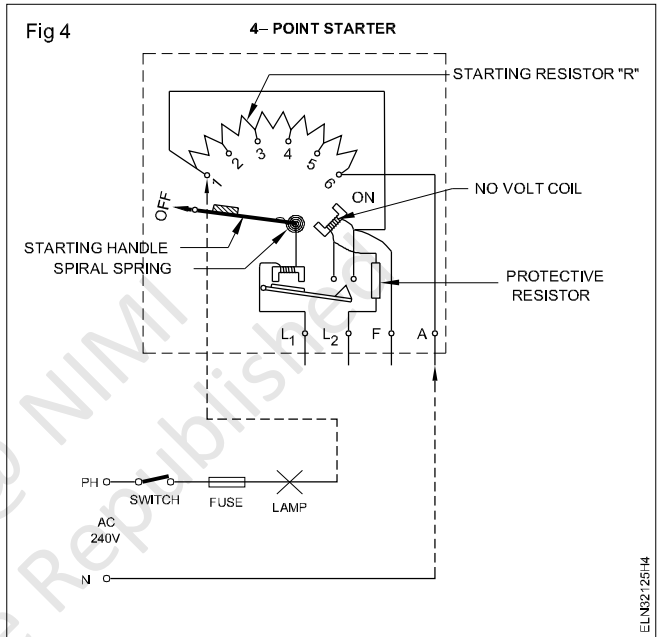
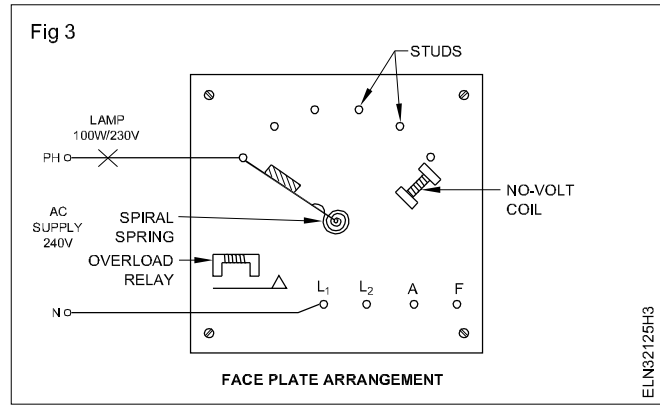

Assemble, service and repair three point and four point DC motor starters

Objectives: At the end of this exercise you shall be able to

- identify the parts of the DC starters
- trace and draw the schematic diagram of the starters
- check and clean the contact studs and the starter resistance
- measure the resistance of the no volt coil
- set the over load relay.

Requirements

Tools/Instruments

- Combination pliers 200 mm - 1 No.
- Screw driver 200 mm - 1 No.
- Multimeter - 1 No.
- Flat file Bastard 150 mm - 1 No.
- Flat file smooth 150 mm - 1 No.
- Ammeter DC 0-30A - 1 No.
- Voltmeter DC 0 - 300 V - 1 No.
- Megger 500 V - 1 No.

Equipment/Machines

- 3 point starter 3 HP 250 V DC - 1 No.
- 4 point starter 3 HP 250 V DC - 1 No.
- DC compound motor 230 V 3HP 10 A - 1 No.

Materials

- DPST main switch 250 V 32 A - 1 No.
- PVC Insulated stranded copper cable 4 sq mm. - 10 m
- Insulation tape - 0.2 m
- Fuse wire of required amps rating - as reqd.
- Carbon tetra chloride - 50 ml.
- Sandal paper No. 1 - as reqd.
- Petroleum jelly - as reqd.

PROCEDURE

General maintenance and servicing

1 Write down the Name-plate details of the given DC motor starter in Table 1.

Table 1
DC starter

DC starter _____	3 point / 4 point
Amps _____	Volts _____
Make _____	Serial No. _____

- 2 Identify the different parts of the starter and draw the starter diagram and label the parts in your record.
- 3 Trace the internal connections of the starter and draw the schematic diagrams. Fig 1 and 2 are given for your guidance.
- 4 Check the contact studs (movable in handle and stationary in face plate of starters) and the starter resistance. Follow the procedure given in chart 1 to rectify the defects.

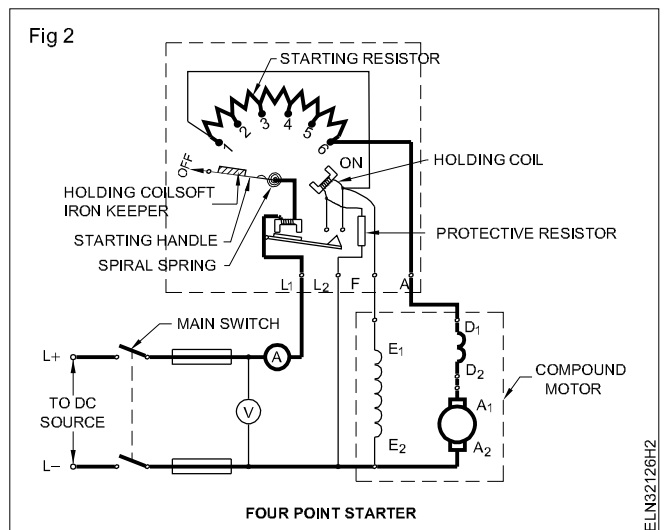
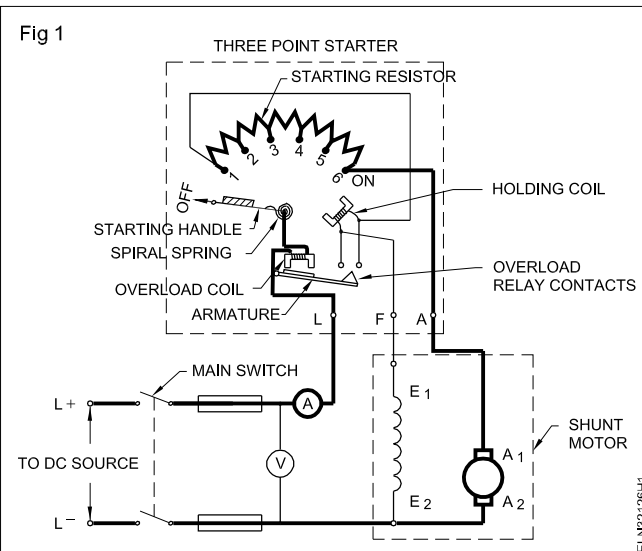

- 5 Visually inspect the colour and condition of the no volt coil and enter the details in Table 2.
- 6 Measure the resistance value of the holding (no-volt) coil as well as that of protective resistance and note the readings in the Table 2.
- 7 Measure the insulation resistance of the coil with respect to the core. Enter the value in Table 2.

If there is any change in the present condition with respect to values obtained at the time of installation, discuss with your instructor. If necessary replace the NVC with a new one having same specification.

- 8 Set the overload relay for the same current rating as of the motor.
- 9 Connect the DC motor with the starter.
- 10 Make necessary loading arrangement for the DC motor.

- 11 Start the DC motor and load it to the rated current.

The starter should not trip at this settings. If it trips, increase the current setting of the overload relay to the next higher value by a small increment. In case the overload relay current setting is much higher, then also starter will not trip.

To find the correct setting reduce the current setting till the starter trips and then slightly increase the current setting till the starter holds. Accordingly recalibrate the overload current rating. Normal setting of the overload relay will be 1.5 times the rated current of the motor.

- 12 Check the starter operation in load condition. In case of any trouble follow the trouble shooting chart and rectify the defect.

Chart 1

General maintenance procedure for DC starters

Trouble area	Cause	Remedy
1 Check the stationary and movable contact studs for burns and pittings.	a) Loosely fitted studs b) Over load c) Insufficient pressure on contact studs due to loosely fitted handle. d) Improper operation.	a) Tighten the nuts in the rear of the contact studs b) Reduce the load. c) Add a washer or two over the handle and tighten the handle studs d) Smoothly manipulate the handle from start to run condition. e) Light burns over the contacts could be cleaned with CTC (Carbon tetra chloride) Heavy burns and pitting need to be dressed with a sand paper or a flat file. f) Apply petroleum jelly over the movable and stationary contact points.
2 Check the starter resistance for open or shorts	a) open resistance are due to excessive heating resulted from: i) wrong starting method ii) excessive load b) Shorted resistance due to: i) excessive vibration of the panel ii) loose mounting of the resistance	a) Do not keep the starter handle in starting position for a long time. i) Reduce the over load. ii) Replace the opened resistance with the equivalent material size and length. b) Reduce the vibration of the panel by proper mounting. ii) Properly mount the resistance.

Table2
No volt coil

Sl. No.	Description	Initial condition at the time of installation		Present condition		Remarks
		Date of installation	Condition	Date	Condition	
1	Colour of the no volt coil (visual inspection)	1.8.2000	Yellow			
2	Resistance value of the no volt coil	1.8.2000	2500 ohms			
3	Insulation resistance between the no volt coil and the core	1.8.2000	5.5 Megohms			
4	Protective resistance of the 4 point starter	1.8.2000	1000 ohms			

Chart2
Trouble shooting chart for DC Starters

Trouble	Cause	Remedy
1 Intermittent current flow in the motor through starter.	<ol style="list-style-type: none"> Loose connections. Stud may not be firm. Insufficient pressure of the handle Formation of dirt. 	<ol style="list-style-type: none"> Tighten all terminals / connections. Tighten the studs. Adjust the pressure Clean the studs with contact cleaner.
2 Handle is not coming to off position when NVC is demagnetised	<ol style="list-style-type: none"> Insufficient spring tension. Gummy material sticking to the faces of the magnet. 	<ol style="list-style-type: none"> Replace the spring with a good one. Clean the magnet faces.
3 Noisy magnet	<ol style="list-style-type: none"> Loose core. Magnetic pole surfaces not making proper contact. Dirt or dust on magnetic faces. 	<ol style="list-style-type: none"> Fix the core firmly Replace the magnetic assembly. Clean with suitable solvent.
4 Failure to pick up handle in 'on' position.	<ol style="list-style-type: none"> Low voltage for no volt coil. Coil open or short . Mechanical obstructions. Soft iron piece on the handle missing. 	<ol style="list-style-type: none"> Check the supply voltage and rectify. Replace the coil. Clean and check up contacts. Fix the soft iron piece on the handle properly such that it is attracted firmly on the magnetic pole face of the no volt coil.
5 Starter is tripping often	<ol style="list-style-type: none"> Incorrect setting of overload relay. Sustained overload. 	<ol style="list-style-type: none"> Set the overload relay properly. Reduce the load.

Practice maintenance of carbon brushes, brush holders, commutator and sliprings

Objectives: At the end of this exercise you shall be able to

- interpret the name-plate details of the DC machine and record it
- inspect the DC machine and pre-test it to locate the fault
- dismantle the DC machine, overhaul it
- maintain and service the parts of the DC machine like carbon brushes, brush holders, commutator and slip rings
- reassemble and test the DC machines
- troubleshoot the DC machine.

Requirements			
Tools/Instruments		Equipment/Machines	
• Electrician tool kit	- 1 No.	• Faulty DC machine 220 V, 3 HP	- 1 No.
• Bearing puller	- 1 No.	• Arbor press	- 1 No.
• DE spanner set 2 mm to 20 mm	- 1 Set	• Dial test indicator	- 1 No.
• MC ammeter 0-500 mA	- 1 No.	Materials	
• MC voltmeter 0-500 mV	- 1 No.	• PVC Insulated copper wire	- as reqd.
• MC voltmeter 0-250V	- 1 No.	2.5 sq mm, 250V grade	
• Growler external with ammeter	- 1 No.	• Cleaning brush 3 cm dia	- 1 No.
• Megger 0-50 meg ohms, 500 V	- 1 No.	• Carbon tetra chloride (CTC)	- 5 0 ml.
• Multimeter	- 1 No.	• Grease type and quantity	- as reqd.
• Wooden mallet 8 cm dia	- 1 No.	• Kerosene - 1 litre	
• Electric air blower 240 V, 50 Hz	- 1 No.	• Lurbication oil type and quantity	- as reqd.
• Under cutting tool	- 1 No.	• Cotton cloth	- as reqd.
• Soldering iron 60W 240V	- 1 No.	• Sand paper/sand cloth-grade	- as reqd.
		and quantity	- as reqd.
		• Solder 60/40	- as reqd.
		• Soldering flux	- as reqd.

PROCEDURE

TASK 1: Check the condition of the DC machine

- 1 Interpret the name-plate details of the given DC motor and record in Table 1. (same Table 1 as in Ex 3.1.115)
- 2 Visually inspect the machine and enter your findings in Table 2.
- 3 Conduct the continuity test, resistance measurement and insulation test and enter the results in Table 3.
- 4 Obtain the above test values at the time of installation from the section in-charge and enter the values in Table 3.
- 5 Dismantle the DC machine.
- 6 Clean each part with the help of a brush and a blower.

Table 2

Visual inspection

Sl. No.	Description	Noticed as/at (strike out items not applicable)
1	Rotation of the shaft	Free / Slightly tight Not rotating
2	Symptom of burn	Armature / Field / Commutator / Brush / Terminal block / No. plate
3	Burning smell	Armature / Field / Commutator / Brush / Terminal block / No plate
4	Damaged parts	
5	Loose connection	

A careful study of the test results and the result values compared between earlier and present conditions will indicate clearly how the machine behaves. Discuss the results with your co-trainees and with the instructor.

Table 3
Test results

Sl.No.	Description of the test	Test result at the time of installation date	Test result before servicing	Test result after servicing
1	Continuity between			
	i) Series field terminals
	ii) Shunt field terminals
2	Resistance value between			
	i) Series field terminals
	ii) Shunt field terminals
3	Insulation resistance value between			
	i) Series field and the frame
	ii) Shunt field and the frame
	iii) Armature and the frame
	iv) Series field and shunt field
	v) Series field and armature
	vi) Shunt field and armature

TASK 2: Service the parts of the DC machine as stated below

- 1 Measure the resistance of each field coil (Fig 1) and compare the value with the figure given by the manufacturer. If it is low or high replace the coil with a similar coil.

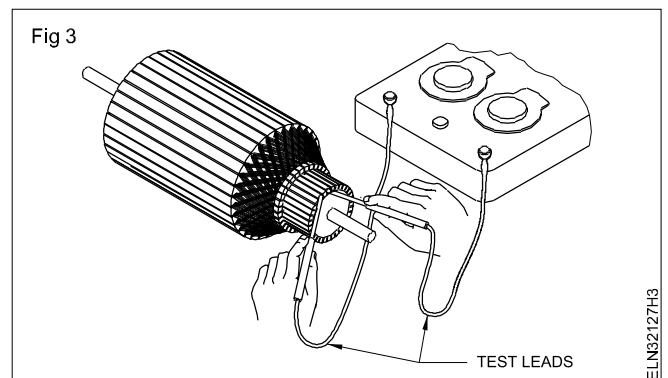
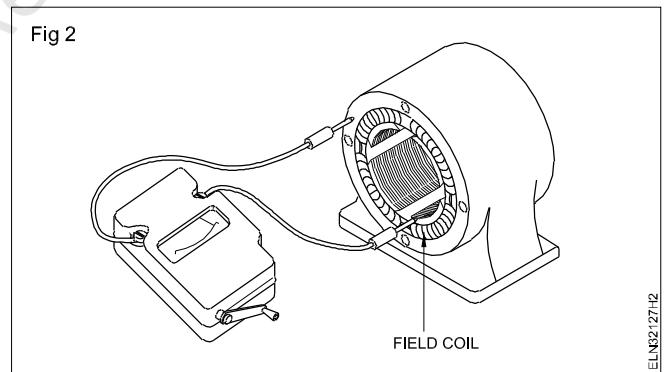
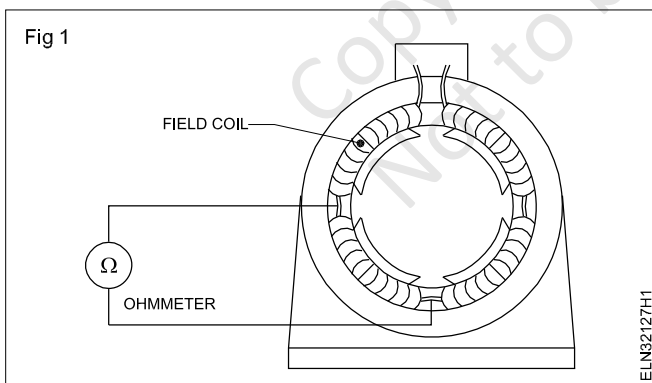

- 2 Measure the insulation resistance between each coil and the frame with a Megger. (Fig 2) If it is low replace the coil with a similar coil. Enter the defect and action taken to rectify the defect in Table 4 in the appropriate place.
- 3 Test the armature for short or open circuits by connecting the ohmmeter test leads to two adjacent commutator bars (Fig 3).
- 4 Set the meter range to get a reading as near mid- scale as possible. (Fig 4)

- 5 Check that the meter reading is the same for all adjacent commutator segments. If not a) a high resistance indicates an open circuit b) a low resistance indicates a short circuit.

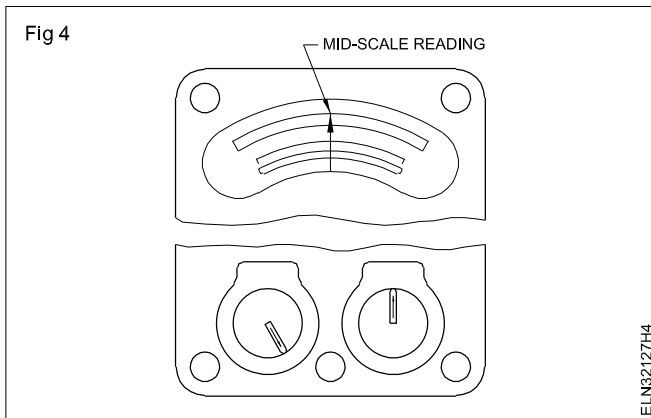

6 Test the armature/commutator for earth fault by connecting one lead of the Megger to the shaft and the other lead of the Megger to the commutator bar. (Fig 5) Enter the defect and the action taken to rectify the defect in Table 4 in the appropriate place.

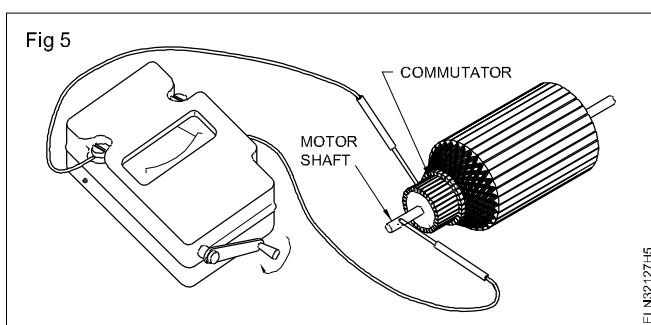

As the commutator is also a part of the armature winding a short or open shown by the above tests involves commutation. Hence check the commutator as explained here before suspecting a coil defect.

Alternatively the armature can be tested for short, open or grounded coils by a growler.

In case a single open or short or ground coil is detected in the above tests, the coil could be replaced with a similar coil; on the other hand if a number of coils are found to be defective, the armature needs to be rewound.

7 Check the commutator for raised mica insulation. If found, under cut the mica. (Fig 6)

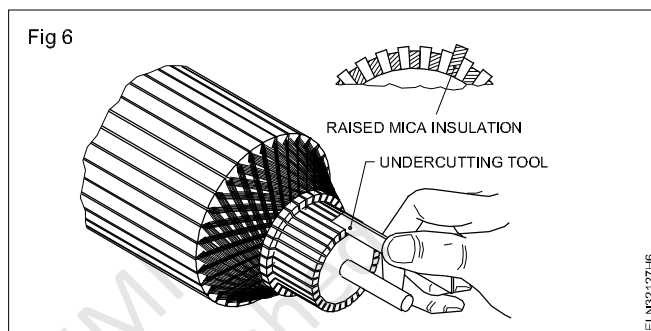

Table 4

Fault and rectification record

Attended by:

Date:

Sl.No.	Area of defect	Action taken for rectification
1	Fault in field coil a) Individual coil resistance measurement is the same as the others/not the same b) Individual coil insulation resistance is the same as the others/not the same	
2	Faults in the armature a) Shorted coil b) Open coil c) Grounded coil	
3	Faults in commutator a) Raised mica b) Pittings in commutator surface c) Burn at commutator segments d) Ridges on commutator e) High bars on commutator f) Defective solder on raisers g) Short between segments	

Sl.No.	Area of defect	Action taken for rectification
4	Defects in brush a) Worn out b) Loose fitting c) Bad bedding d) Defective spring tension	
5	Defects in bearing a) Worn out b) Damaged c) Dry	

A tool made from a piece of hacksaw blade with the sides of the tooth ground down parallel to the thickness of the mica and held in a suitable holder (Fig 7) could be used for undercutting the mica.

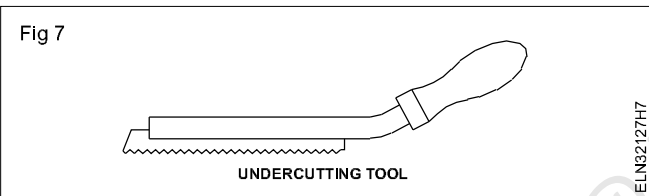

8 Check the commutator for pittings, ridges and high bars. (Fig 8). If found, they could be removed by skinning the commutator. (Turning in a lathe)

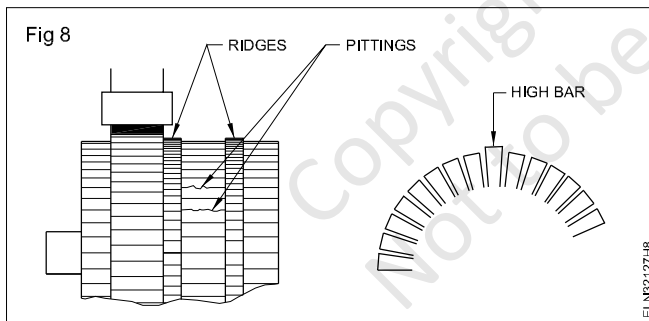

The commutator can only be turned to a minimum diameter specified by the manufacturer.

9 Verify before skinning (turning) check with a dial test indicator that the shaft centre is the true commutator centre. (Fig 9)

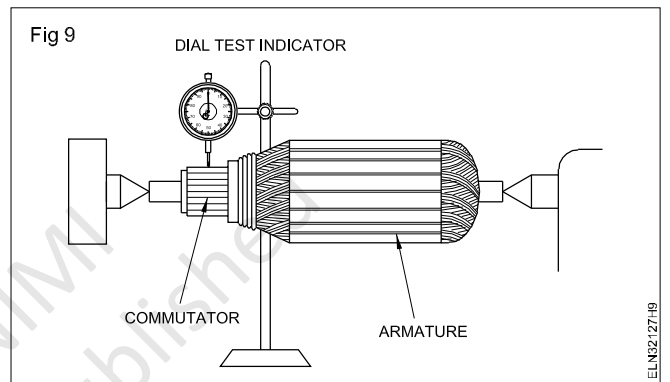

10 Get the help of a good turner and do mount the armature in a lathe. Use a driving dog to turn the shaft and remove minimum copper from the surface of the commutator till the pitting, ridges and high bars are rectified. (Fig 10)

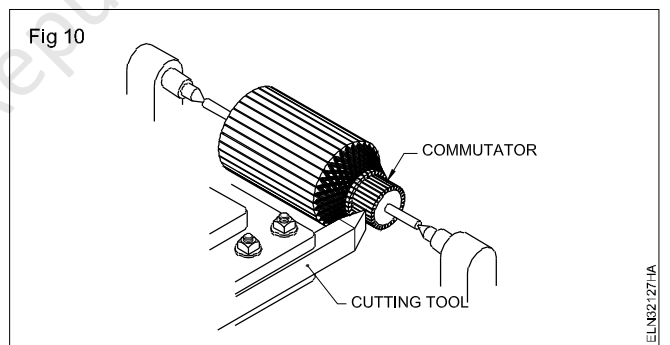

11 Clean by using the sandpaper/sand cloth to give fine finish to the commutator surface. (Fig 11) Enter the defect and the action taken to rectify the defect, in Table 3 in the appropriate place.

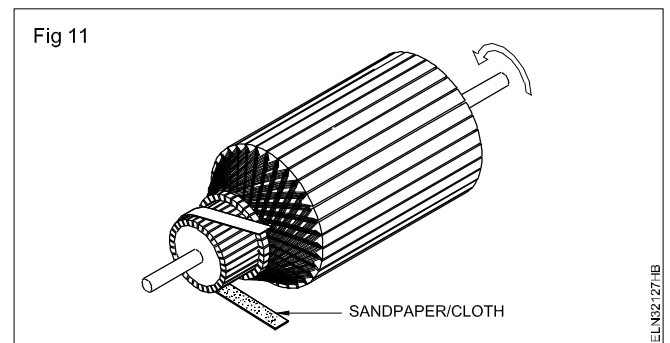

After finishing, check again for raised mica if necessary undercut the mica.

Badly damaged commutator needs to be replaced by a new one having the same specification.

12 Check the commutator connections in the raisers. If necessary, resolder the suspected soldering spots. (Fig 12)

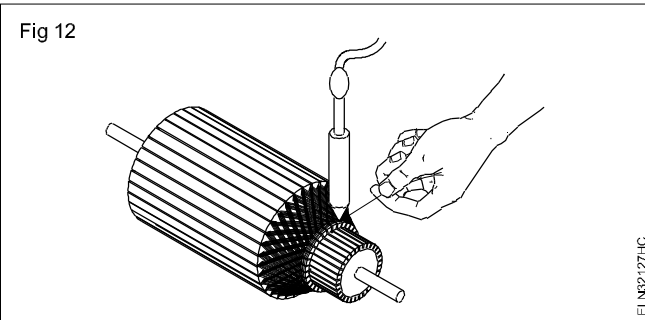

13 Clean away the dust, dirt and carbon deposits from the brush holder and assembly using Carbon Tetrachloride (CTC)

14 Check the length of the brushes using scale.

If the length of the brush is reduced to 1/3rd of the original length, the brush should be replaced.

In case a new brush is to be replaced in place of the old one, the new brush should have the specification as recommended by the manufacturer.

15 Check new brush whether it slides freely in the holder without undue side play. If necessary fit with a smooth file. Keeping the brush sides parallel. (Fig 13)

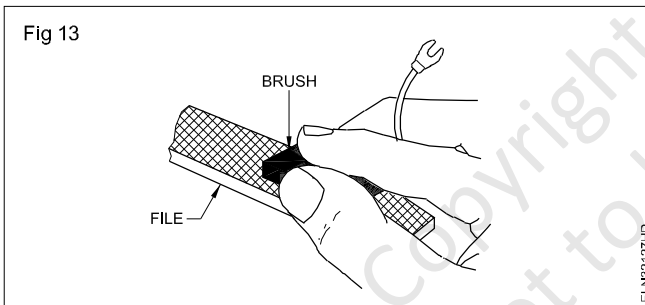

16 Insert the new brush and shape the end of the curve of the commutator, using glass-paper wrapped around the commutator and light pressure in the brush. (Fig 14)

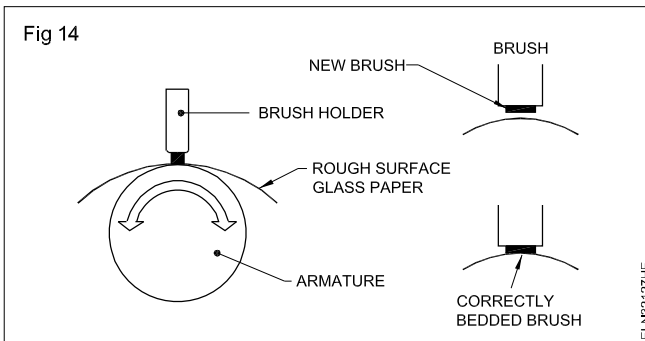

17 Assemble the brush in the brush holder check that the brush holders are not more than 1.5 mm (1/16 in.) away from the commutator surface. If necessary adjust, keeping them square to the commutator. (Fig 15)

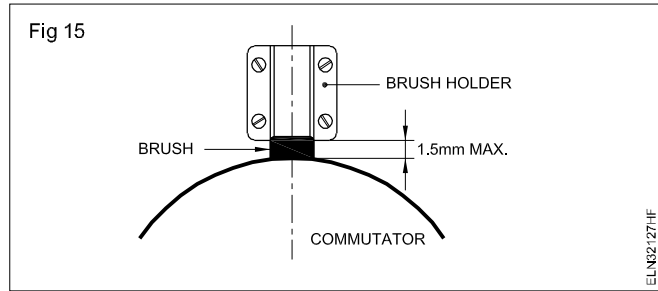

18 Check the spring tension. If it is adjustable, set it to the minimum pressure that will prevent sparking or follow the directions given by the manufacturer. (Fig 16.)

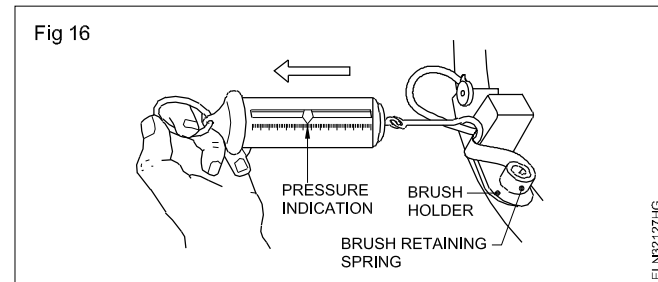

19 Check the bearing for play, wear and damage.

20 Clean the bearing using kerosene and then with lubricating oil.

21 Back the recess with a grease recommended by the manufacturer up to 80% of the space.

22 Identify the bearing which is found defective, remove the defective one with the help of a bearing puller.

23 Replace it with a bearing having the same specification.

24 Refit the inner bearing plate and then press the bearing on to the shaft in an arbor press, using a tube and a plate to apply pressure to the inner ring of the bearing. (Fig 17)

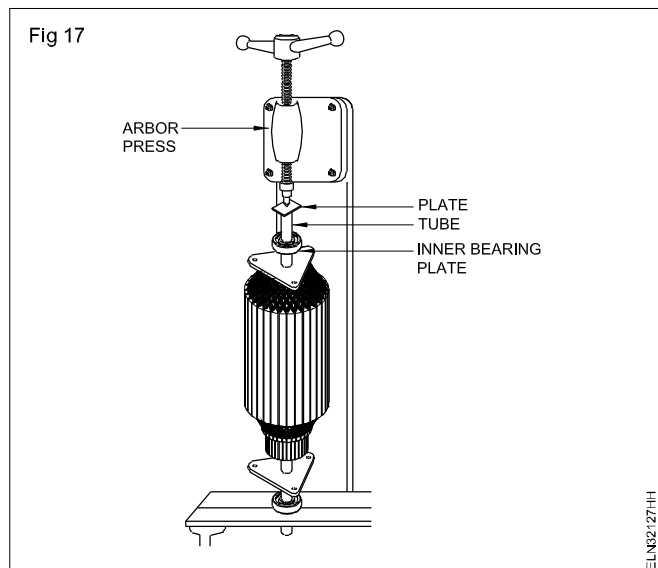

Start, run and reverse direction of rotation of DC series, shunt and compound motors

Objectives: At the end of this exercise you shall be able to

- connect a 2 point starter and start the motor
- reverse the direction of rotation of a DC series motor
 - by changing the armature terminals.
 - by changing the field terminals.
- connect a 3 point starter to a DC shunt motor, start and run the motor
- reverse the direction of rotation of a DC shunt motor
 - by changing the armature terminals
 - by changing the field terminals
- connect, start and run a DC compound motor through a 4 point starter
- reverse the direction of rotation of a DC compound motor
 - by changing the armature connections (method 1)
 - by changing the shunt field and series field connections (method 2)
- measure the speed of the motor by using a revolution counter and stop watch.

Requirements			
Tools/Instruments			
• Insulated cutting pliers 150mm	- 1 No.	• Loading arrangement or complete brake test arrangement	- 1 Set
• Megger 500 V	- 1 No.	• D.C shunt motor 220V 3HP	- 1 No.
• Screwdriver 150mm	- 1 No.	• ICDP switch 250V/16A	- 1 No.
• D.E. spanner set 5mm to 20mm	- 1 Set	• 3 Point starter suitable for 220V 3HP D.C shunt motor	- 1 No.
• Shunt type ohmmeter 0-2K or multi meter	- 1 No.	• Motor compound DC 220Volts and 2 to 3HP	- 1 No.
• Test lamp with 220V 25W lamp	- 1 No.	• 4 Point starter 220V 16A	- 1 No.
• Revolution counter cyclometer 4 digits	- 1 No.		
• Stop watch 30 minutes	- 1 No.		
Equipments/Machines		Materials	
• DC series motor 220V 3 H.P	- 1 No.	• 2.5sq mm P.V.C. copper multi-strand cable	- 18 m
• 2-point starter for 220V 3 H.P. DC series motor	- 1 No.	• Fuse wire 15 amps	- as reqd.

PROCEDURE

TASK 1: Connect, start and run a DC series motor

1 Fix and arrange a suitable load for the series motor.

The series motor should not start or run without a load. A flat belt drive, which might slip, while running should not be used. Fig 1 shows the loading through brake arrangement. The belt over the pulley should be marginally tightened to apply a certain load on the motor.

2 Select a proper rating of the I.C.D.P. switch, cables, fuse wire and 2-point starter, according to the rating of the given DC series motor.

The rating of the switch, fuse, cable and 2-point starter given here is for a 220 V 3 HP DC series motor.

3 Open the 2-point starter, identify the parts, trace the connection and draw the connection diagram.

4 Connect the motor as per a circuit diagram (Fig 1) and get it approved by the instructor.

Check whether the belt is in position for loading the pulley.

5 Switch 'ON' the I.C.D.P. and move the 2-point starter gradually in the clockwise direction, till the 'ON' position is reached and observe the direction of rotation.

6 Record the direction of rotation in Table 1.

7 Measure the speed with a tachometer and enter the value in Table 1.

- Stop the motor by switching off the I.C.D.P. and wait till the starter handle comes to the 'OFF' position. Remove the fuse.

If the 2-point starter provided to you is without the hold on coil and spring-loaded handle, then the starter handle needs to be brought to the 'OFF' position manually after switching 'OFF' the supply.

When reversing any motor, we should allow it to come to a dead stop and then operate it in the opposite direction.

Table 1

Sl. No.	Figure	Direction of rotation	Speed in r.p.m.
1	Fig 1		
2	Fig 2		
3	Fig 3		
4	Fig 4		

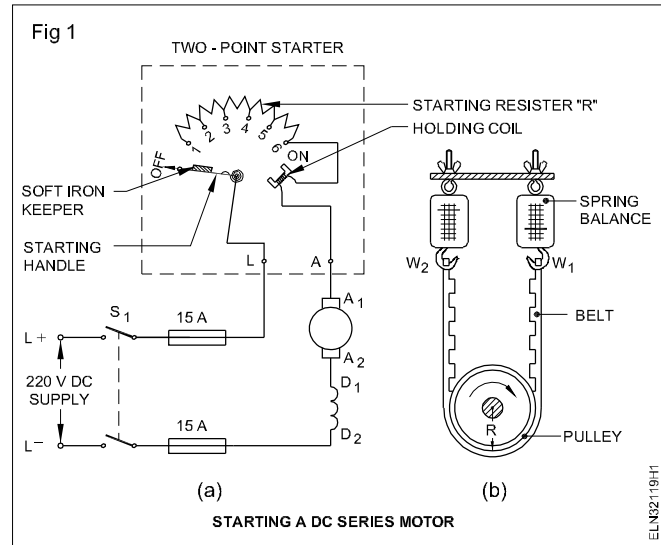

TASK 2 : Reverse the direction of rotation of a DC series motor

METHOD 1 : Reverse the direction of rotation by changing the armature terminals

- Connect the motor as per circuit diagram Fig 2 and check the loading arrangement for the correctness. Repeat steps 5 to 8 of Task 1.

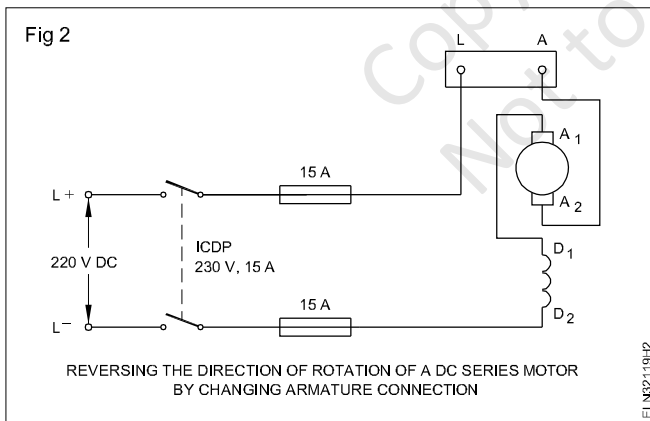

METHOD 2 : Reverse the direction of rotation by changing the field terminals.

- Connect the motor as per circuit diagram Fig 3 and check the loading arrangements for its correctness. Repeat steps 5 to 8 of Task 1.
- Change the supply terminals as per circuit diagram (Fig 4) and the loading arrangements for correctness. Repeat steps 5 to 8 of Task 1.

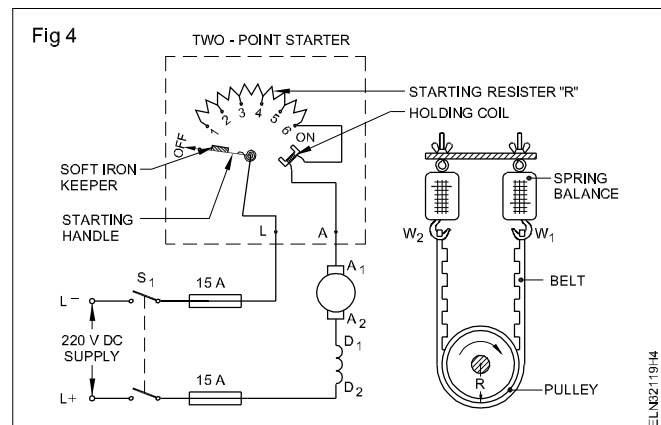
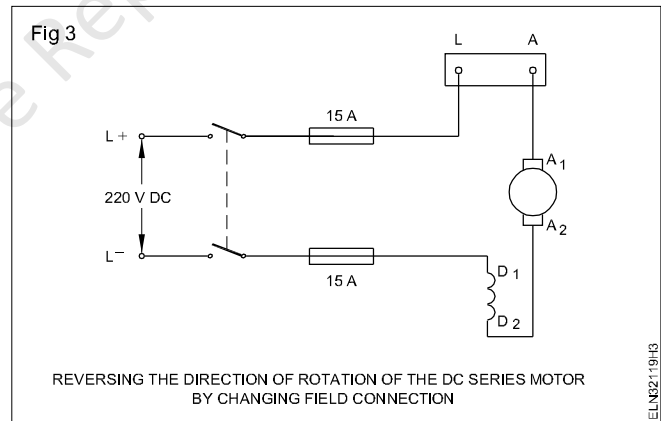

- Compare the connections in Fig 1 and Fig 4. Check the direction of rotation in both the cases.
- Write the conclusion based on this experiment in the space given below.

Conclusion

TASK 3: Connect, start and run a DC shunt motor

- Select the ICDP switch, 3-point starter, fuse wire and cable according to the given specification.

The specification here is for DC shunt motor 220v, 3HP rating. If the available DC shunt motor in the shop floor is not of the same rating, the specification will have to be changed.

- Open the 3-point starter, trace the connections and sketch the internal parts.
- Measure the resistance of the series resistor and the no-volt coil of the starter. Enter these values in Table 2.
- Connect the DC shunt motor as per circuit diagram. (Fig 5)
- Check the supply voltage and confirm by verifying with the data given in the name-plate.
- Check the rating of the fuses in the main switch. If required, change it in accordance with the motor rating.
- Switch 'ON' the ICDP and gradually move the starter handle to the 'ON' position.
- Check the direction of rotation and enter it in Table 3.
- Stop the motor by switching 'OFF' the ICDP. Wait until the shaft comes to a standstill position.
- Remove the fuse-carriers from the ICDP.

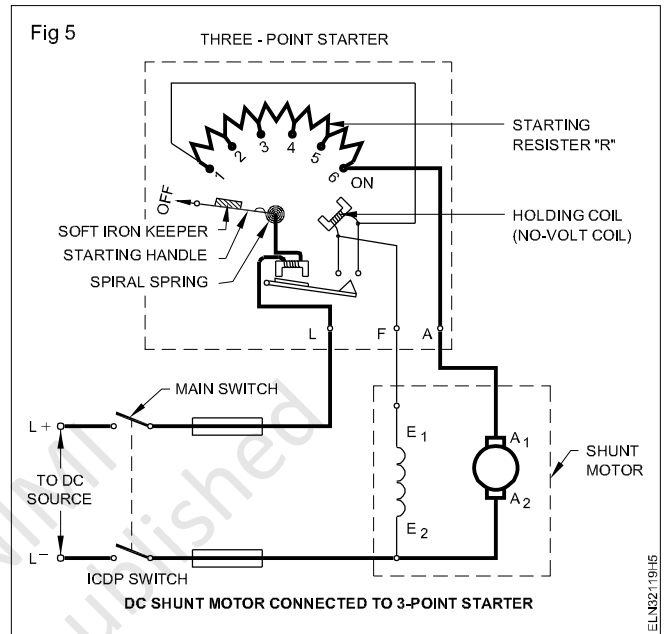

Table 2

Resistance of the series resistor (in ohms)	Resistance of the no-volt coil (in ohms)

Table 3

SI.No	Description	Direction of rotation
1	Normal connection as in Fig 5	
2	By changing armature terminals as in Fig 6	
3	By changing shunt field terminals as in Fig 7	

TASK 4: Reverse the direction of rotation of a DC shunt motor

METHOD 1: Change the direction of rotation by changing the armature terminals.

- Reconnect the DC shunt motor as per circuit diagram. (Fig 6)
- Replace the fuse-carriers.
- Repeat the working steps 7 to 10 of Task 3.

METHOD 2: Change the direction of rotation by changing the shunt field terminals.

- Reconnect the DC shunt motor as per circuit diagram. (Fig 7)
- Replace the fuse-carriers.
- Repeat the working steps 7 to 10 of Task 3.

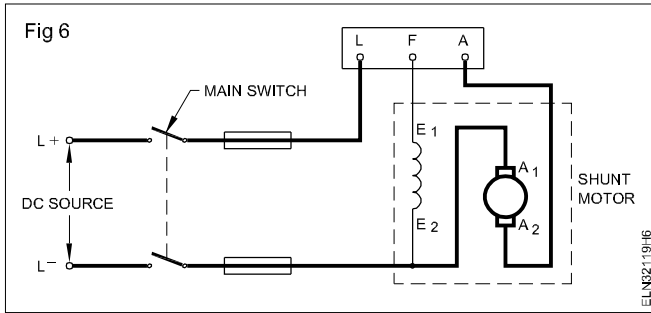

Only one pair of terminals, either armature or shunt field, should be changed. If both the armature and shunt field terminals are changed, the direction of rotation will not change.

Write the conclusion:

a Necessity of starter

b Method of changing the direction of rotation in a DC shunt motor based on Fleming's left hand rule.

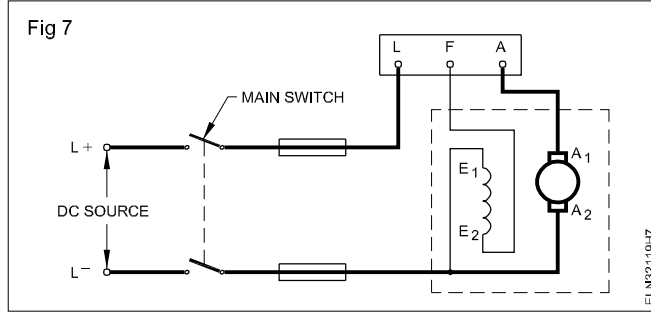

TASK 5: Connect, start and run a DC compound motor

- 1 Read and interpret the name-plate details of the given DC compound motor and record it.
 - 2 Identify the terminals, and test for the insulation resistance of the given DC compound motor.
 - 3 Select proper sizes of switch, starter and cables according to the rating of the given DC compound motor.
- The ratings of the switch, starter, cables etc. given here are for a DC compound motor of 220V 3 HP rating. If the motor rating changes, the rating of the switch, starter, cable etc. should also be changed.**
- 4 Open the 4-point starter, trace the connection, sketch the internal parts and draw the diagram. Measure the resistance of the series resistor, protective resistor, no-volt coil and enter the values in Table 4.
 - 5 Select and insert a suitable fuse wire in the main ICDP switch according to the rating of the given motor.

6 Give the connections as per circuit diagram. (Fig 8)

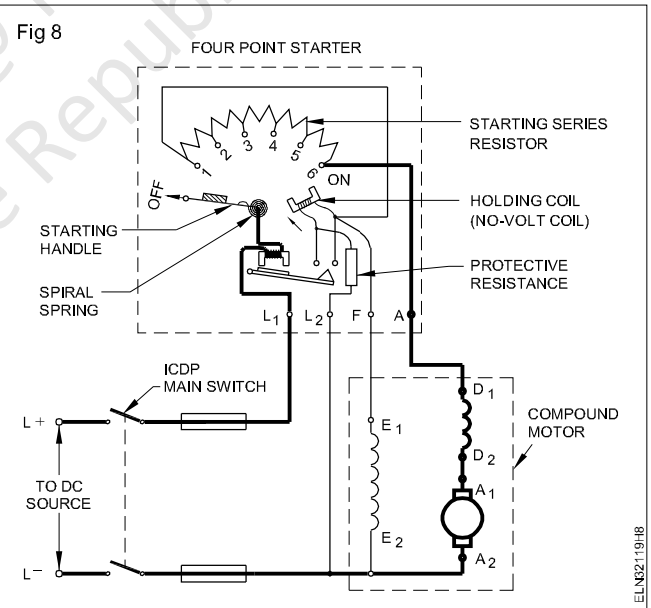

Table 4

Value of the series resistance of the starter (in ohms)	Value of the protective resistance (in Kilo ohms)	Value of the no-volt coil resistance (in ohms)

- 7 Connect the ICDP switch to the rated DC supply voltage of the motor.
- 8 Switch on and move the 4-point starter handle slowly until the 'ON' position is reached.
- 9 Observe the direction of rotation of the motor. The direction of rotation of the motor is _____
- 10 Take the revolution counter, set the readings to zero, and fix the rubber tip.
- 11 Take the stopwatch and set its reading to zero.

The rubber tip of the revolution counter should be engaged to the shaft centre of the motor. The revolution counter and the stopwatch need to be started at the same time and stopped at the same time.

- 12 Hold the revolution counter in the right hand and the stopwatch in the left hand.
- 13 Engage the rubber tip of the revolution counter in the centre of the shaft of the motor.

Stand away but in front of the shaft and engage the rubber tip slowly in the small countersink position of the rotating shaft.

- 14 Press the start-button of the revolution counter and the stopwatch simultaneously.
- 15 Press the 'off' button of the stopwatch just when the stopwatch reads one minute and the revolution counter simultaneously. Read the revolution per minute. Speed of the motor in revolution per minute is _____

If you are not able to stop the stopwatch exactly in one minute, follow the procedure given below. (However the stopwatch and the revolution counter ought to have been stopped at the same time)

'N' Number of revolutions recorded in counter for a time of 'X' minutes as recorded by the stopwatch.

Revolution per minute =

$$\frac{\text{'N' Number of revolutions in counter}}{\text{Stopwatch time in 'X' minutes}} = \text{r.p.m.}$$

- 16 Stop the motor by switching off the ICDP switch, wait till the shaft comes to rest.

TASK 6: Reverse the direction of rotation of a DC compound motor

METHOD 1: Reverse the direction of rotation of the DC compound motor by changing the armature connection

- 1 Interchange the terminal of the armature. (Fig 9)

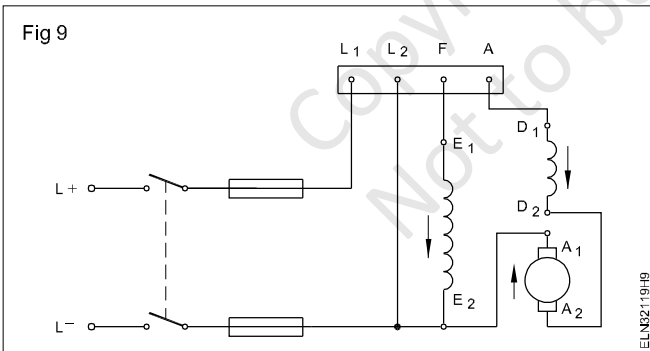

- 2 Switch 'ON' and start the motor by the starter; observe the direction of rotation. The direction of rotation of the motor is _____.
- 3 Stop the motor by switching off the I.C.D.P; wait until the motor stops completely.

METHOD 2: Reverse the direction of rotation of the DC compound motor by changing the shunt field terminals and series field terminals.

As explained, the series field terminals also need to be changed in this case, to retain the earlier characteristics of the compound motor.

- 1 Interchange the field terminals. (Fig 10).

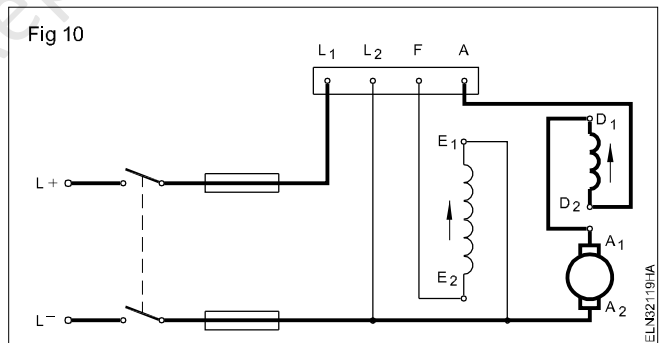

- 2 Switch 'ON' and start the motor by the starter and observe the direction of rotation. The direction of rotation of the motor is _____
- 3 Switch off the supply. Write your observation regarding the method of changing the direction of rotation of the DC compound motor in the space given below.

- 4 Show your observations to your instructor.
- 5 Disconnect the connections and keep the tools, equipment and materials in their proper places.

Perform speed control of DC motors field and armature control method

Objectives: At the end of this exercise you shall be able to

- read and interpret the name-plate details of a DC machine
- identify the terminals of a DC machine
- connect the DC shunt motor through a 4-point starter and a shunt field regulator
- start and run a DC shunt motor
- measure the speed of a DC motor
- vary the speed of a DC motor using the shunt field control regulator, and find the relationship between the field current and speed
- vary the speed of a DC motor using armature circuit resistance and find the relationship between armature voltage and speed.

Requirements

Tools/Instruments

- Insulated cutting pliers 200mm - 1 No.
- Screwdriver 200mm - 1 No.
- Electrician's knife (100 mm) - 1 No.
- M.C. ammeter 0-1A - 1 No.
- M.C. voltmeter 0-300V - 1 No.
- Tachometer 300-3000 r.p.m. - 1 No.
- Megger - 500V - 1 No.
- Test lamp - 1 No.
- M.C. ammeter 0 to 15A - 1 No.

Equipment/Machines

- DC shunt motor 220V 3HP - 1 No.
- Rheostat 220 ohms 1 amp - 1 No.
- 4-point starter 15A 220V - 1 No.
- Rheostat 20 ohms 15 amps - 1 No.
- 3 point starter 15A 220V - 1 No.

Materials

- P.V.C. Insulated multi-strand copper cable 2.5 sq mm 600V grade - 10 m
- Fuse wire 15 Amps - as reqd.

PROCEDURE

TASK 1: Control the speed of a DC shunt motor by the field control method

- 1 Note the name-plate details of the given DC shunt motor and record it in table 1 as in exercise no 3.1.115
- 2 Identify the terminals of the given DC shunt motor and test for insulation and ground.
- 3 Select a suitable range of rheostat, ammeter, voltmeter, switch and fuse according to the specification of the given DC shunt motor.
- 4 Make the connections as per the circuit diagram. (Fig 1) .

The rheostat position must be in the cut out position at the time of starting to have a low starting speed.

- 6 Apply the rated supply voltage through the switch and start the motor by the 4-point starter.
- 7 Measure the speed, field current, voltage and enter them in Table No 2.
- 8 Decrease the field current by increasing the field control resistance in steps.

Calculate 130% of the speed value from the name-plate details. The speed should not be more than 30% of the rated value.

- 9 Measure the speed, field current, and the applied voltage for each step and enter these values in Table 2.
- 10 Switch OFF the supply of motor.
- 11 Draw the speed versus field current curve in a graph sheet, keeping the field current in the X-axis and the speed in the Y-axis.
- 12 Write your observation highlighting the relation between speed, field current and field flux.

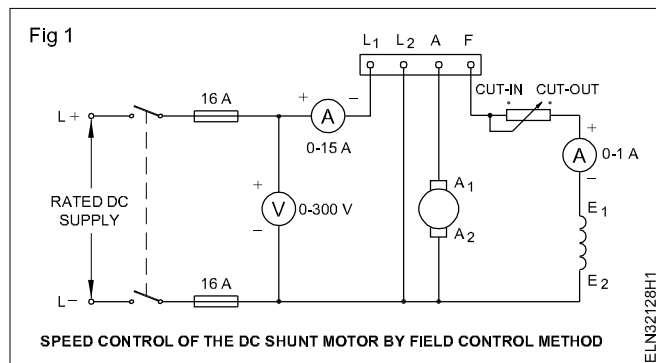

- 5 Keep the field rheostat in the cut out position to have minimum resistance in the shunt field circuit.

Observation

Table 2

Sl.No.	Voltage	Line current (I _L)	Field current (I _{SL})	Speed rpm
1				
2				
3				
4				
5				
6				

TASK 2: Control the speed of a DC shunt motor by the armature resistance method

- Note the name-plate details of the given shunt motor and record it.
- Identify the terminals of the given DC shunt motor and test for insulation and ground.
- Select the 3-point starter, rheostat, ammeter and voltmeter according to the rating of the given DC shunt motor.
- Make the connections as per the circuit diagram. (Fig 2)
- Keep the armature circuit rheostat in the cut out position.
- Apply the rated voltage and start the motor by using the 3- point starter.
- Measure the speed, armature current & voltage across the armature and enter them in Table 3.
- Increase the armature circuit resistance gradually and check the speed and corresponding armature current and voltage across the armature.
- Repeat step No 7 for each variation .
- Switch `OFF' the supply to the motor.
- Draw the speed and armature voltage characteristic curve in the graph sheet, keeping voltage in the X-axis and speed in the Y-axis.
- Write your conclusion highlighting the relationship between the voltage across the armature and speed.

Note: Back emf =

$$E_b = \text{Applied voltage} - \text{Total armature circuit voltage drop}$$

$$= E - I_a R_T$$

$$= E - I_a (R_a + R_{ar})$$

$$E_b = \text{Applied voltage} - (\text{Internal armature resistance drop} + \text{External armature rheostat drop})$$

Assuming the internal armature resistance drop is negligible, we can also assume voltage across the armature = back emf E_b .

Conclusion

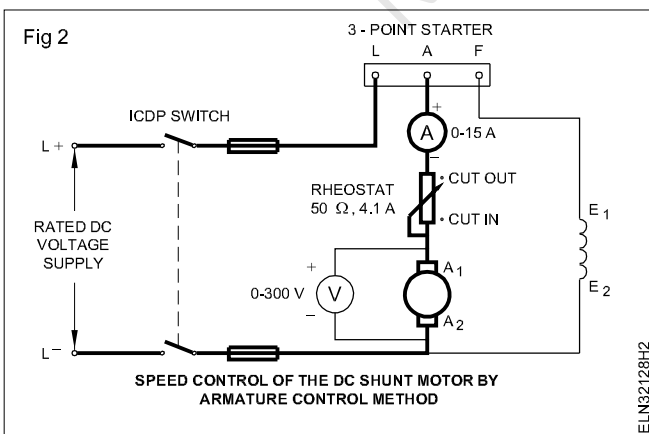

Table 3

S.No.	Armature current (I_a)	Voltage across armature	Speed r.p.m.	Remarks

Copyright @ NIMI
Not to be Republished

Practice dismantling and assembling in DC shunt motor

Objectives: At the end of this exercise you shall be able to

- read and interpret the name-plate details of a DC shunt motor
- conduct visual inspection of the electrical machine
- dismantle the DC shunt motor
- remove, inspect and install the bearings
- clean the parts of DC shunt motor
- reassemble the DC shunt motor
- adjust the brush tension and bedding of brushes, and correct the rocker arm position
- check the performance of DC shunt motor.

Requirements

Tools/Instruments

- Pulley puller 6" - 1 No.
- Hammer 500 gms - 1 No.
- Cutting pliers 200mm - 1 No.
- Centre punch 100mm. length - 1 No.
- Spanner set 5mm to 20mm - 1 Set.
- Screwdriver, heavy duty - 200 mm
- Tray 300 x 300 mm x 50 mm - 1 No.
- Mallet, hardwood 60mm dia. - 1 No.
- "Man on line" board - 1 No.
- Electric blower - 250V 50HZ - 1 No.

Equipment/Machines

- DC Shunt motor - 1 No.

Materials

- Kerosene - 1 litre
- Cotton cloth - 1/4 sq.m.
- Carbon tetrachloride - 100 ml.
- Round brush for cleaning 2cm - 1 No.
- Petrol - 200 ml.
- Sand paper No.1 - 1 Sheet
- Hacksaw blade 300 mm - 3 Nos.
- Sand paper 'oo' smooth - 1 Sheet
- Mobile oil S.A 40 - 1/2 litre
- Cotton waste - 100 gms
- Shell alvania 3 grease or equivalent - 100 gms
- Hardwood 3cm sq. 20cm long - 2 Pieces

PROCEDURE

- 1 Read the manufacturer's instruction booklet, and particularly take into account any special instructions regarding dismantling procedures.
- 2 Remove the fuse-carriers from the main switch, disconnect the DC machine from the supply and display the "Man-on-line board" on the main switch.
- 3 Remove the foundation bolts of the machine, shift the machine to the workbench and note the name-plate details in Table 1 as shown is Exercise 3.1.115
- 4 Conduct a visual inspection.
- 5 Clean the outside surface of the motor. Remove all dirt and grease with a dry cloth soaked in petrol/kerosene.

Do not use water.

- 6 Make punch marks on both the end plates and yoke. (Fig 1)
- 7 Mark the rocker arm position with respect to the end plate.

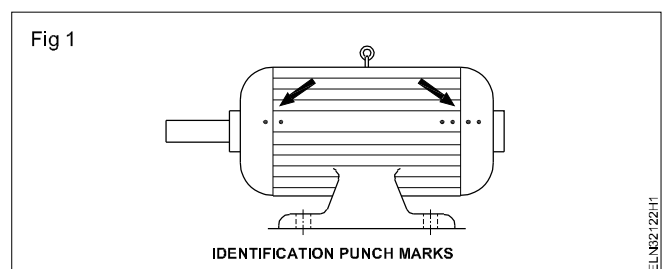

8 Remove the brushes from the brush-holder. (Fig 2)

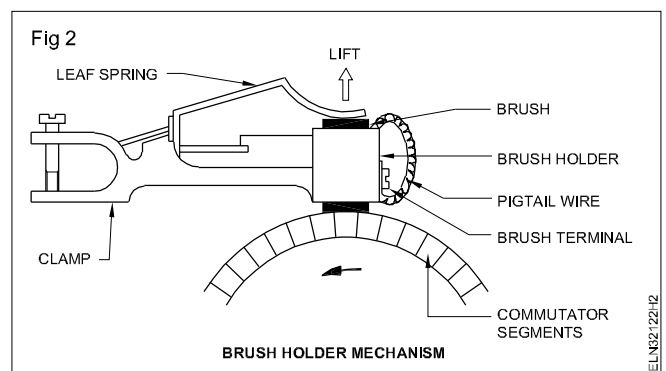

- 9 Check pulley tightness and adjust. Remove pulley it with a pulley puller if the pulley is found tightly fitted. (Fig 3)

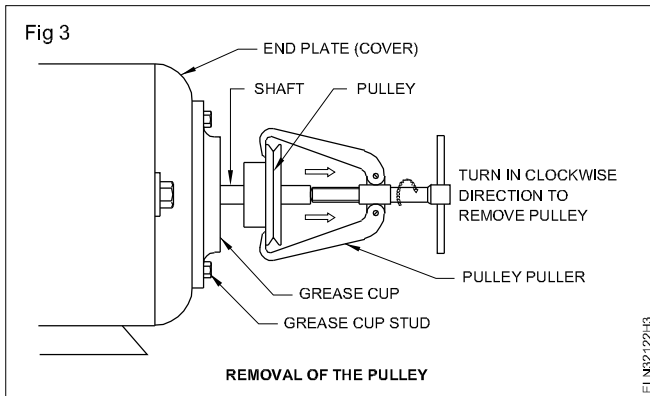

- 10 Remove the grease cup stud and open the grease cup. (Fig 4)

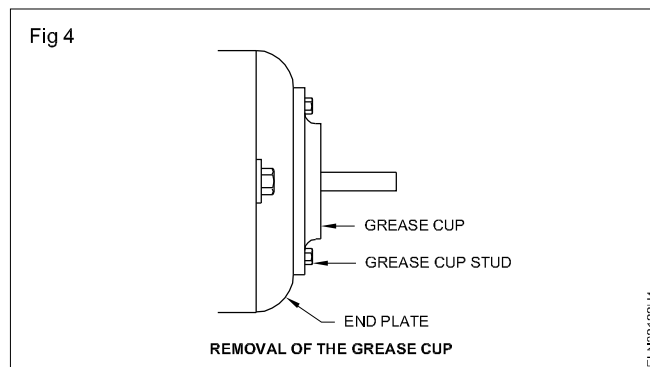

- 11 Loosen the studs of both the end plates and then remove the end plate of the shaft side.

Open one end of the end plate slowly by holding the armature shaft by hand or pulley block so that the weight of the armature does not damage the pole faces or field windings.

- 12 Remove the armature from the body of the machine. (Fig 5).

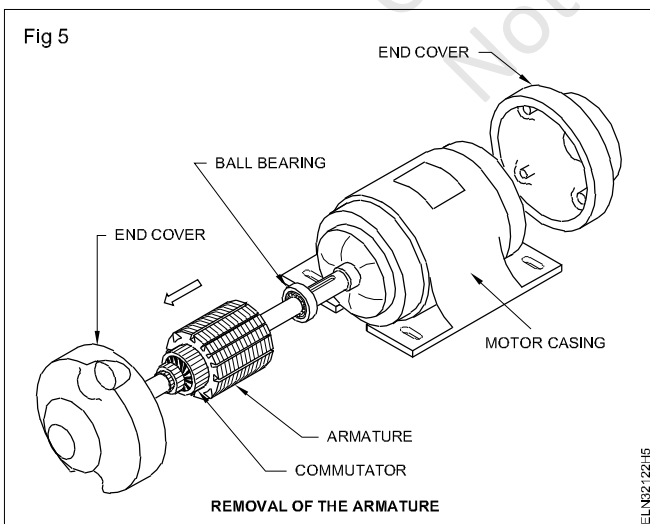

- 13 Remove the bearings using a bearing puller. (Fig 6)

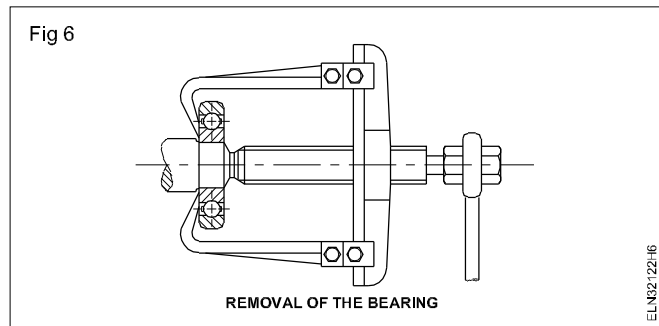

New bearings need no cleaning. Do not remove the new bearings from the package until needed. Before opening the new bearing, keep the workbench clean and tidy. For fixing the bearing in the shaft, follow the guidelines (Fig 7).

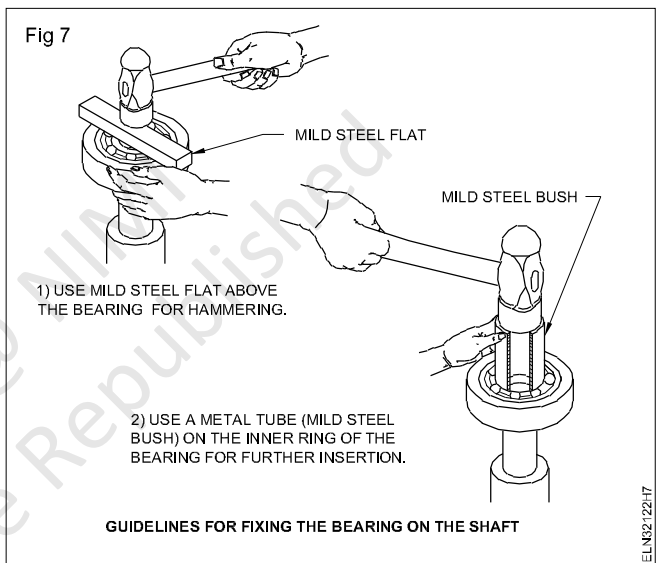

- 14 Reassemble the yoke, armature and end plates.

- 15 Check the freeness of the shaft by rotating the shaft by hand.

If found tight (not free) loosen the end-plate studs and tighten the crosswise studs gradually in the proper sequence, and at the same time feeling the shaft for free rotation.

- 16 Insert the brush in the holder, adjust the brush tension, and bed the brushes following the procedure shown in Fig 8.

- 17 Position the rocker-arm in the end plates as per original marking.

- 18 Re-install the machine in the foundation and tighten the foundation bolts and connect the motor to the supply.

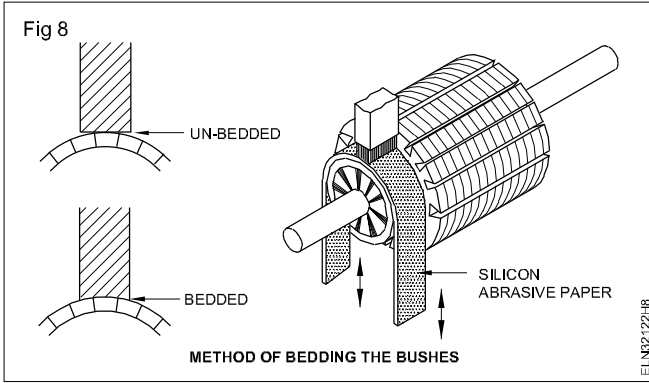

19 Check whether the motor is operating smoothly without any vibration. A check-list for mechanical functions is given in Table 1. Fill up all the possible columns after checking the motor operation.

Table 1

Sl. No.	Check-list (Mechanical)	Remarks
1	Noise	
2	End-play	
3	Rotor running free	
4	Bearing fits	
5	Lubrication, grease, nipples oil supply	
6	Temperature bearings	
7	Temperature motor frame	
8	Condition of shaft, keyway, pulley, bearing seals	
9	Bolts, nuts tightened	

Copyright @ NIMI
Not to be Republished

Carry out overhauling of DC machines

Objectives: At the end of this exercise you shall be able to

- read and interpret the name-plate details of a DC machine
- conduct visual inspection of the electrical machine
- measure the resistance of windings and test the machine for insulation
- dismantle the DC machine
- remove, inspect and install the bearings
- clean the parts of DC machine
- test the armature and inspect the commutator
- reassemble the DC machine
- adjust the brush tension and bedding of brushes, and correct the rocker arm position
- check the performance at no-load and load.

Requirements			
Tools/Instruments		Equipment/Machines	
• Pulley puller 6"	- 1 No.	• DC machine	- 1 No.
• Hammer 500 gms	- 1 No.	Materials	
• Cutting pliers 200mm	- 1 No.	• Kerosene	- 1 litre.
• Centre punch 100mm length	- 1 No.	• Cotton cloth	- 1/4 sq. m.
• Spanner set 5mm to 20mm	- 1 set	• Carbon tetrachloride	- 100 ml.
• Screwdriver, heavy duty	- 200 mm	• Round brush for cleaning 2cm	- 1 No.
• Tray 300 x 300 mm	- 1 No.	• Petrol	- 200 mil.
• Midget screwdriver	- 25 mm	• Sand paper No.1	- 1 sheet.
• Megger 500 volts	- 1 No.	• Hacksaw blade 300 mm	- 3 Nos.
• Blowlamp 1/2 pint	- 1 No.	• Sand paper `oo' smooth	- 1 sheet
• External growler	- 1 No.	• Mobile oil S.A 40	- 1/2 litre
• Mallet, hardwood 60mm dia.	- 1 No.	• Cotton waste	- 100 gms
• "Man on line" board	- 1 No.	• Shell alvania 3 grease or equivalent	- 100 gms
• Multimeter	- 1 No.	• Hardwood 3cm sq. 20cm long	- 2 pieces

PROCEDURE

TASK 1: Dismantle, insert and reassemble DC machine

- 1 Note the name-plate details in Table 1. (Same table as Exercises no 3.1.115)
- 2 Conduct a visual inspection and record the defects, if any, in Table 2.
- 3 Test the winding of field and armature for insulation and record in Table 3.
- 4 Clean the outside surface of the motor. Remove all dirt and grease with a dry cloth soaked in petrol/kerosene.
- 5 Make punch marks on both the end plates and yoke (Fig 1).

Do not use water.

Table 2
Visual Inspection Report

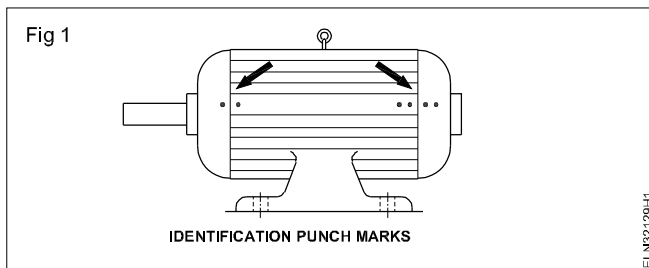

Table 3

Insulation test report

Sl.No.	Between terminals	Insulation resistance in megohms		
		Before overhauling	During overhauling	After overhauling
1	Armature and shunt field			
2	Shunt and series field			
3	Series field and armature			
4	Shunt winding to body			
5	Series winding to body			
6	Armature winding to body			

6 Mark the rocker arm position with respect to the end plate.

7 Remove the brushes from the brush-holder. (Fig 2)

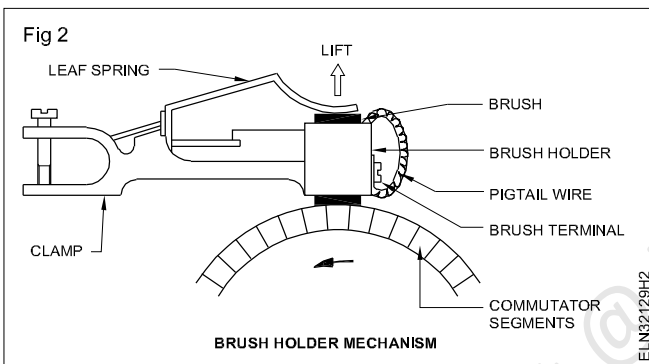

8 Remove pulley with a pulley puller. If the pulley is found tightly fitted, check pulley tightness and adjust pulley. (Fig 3)

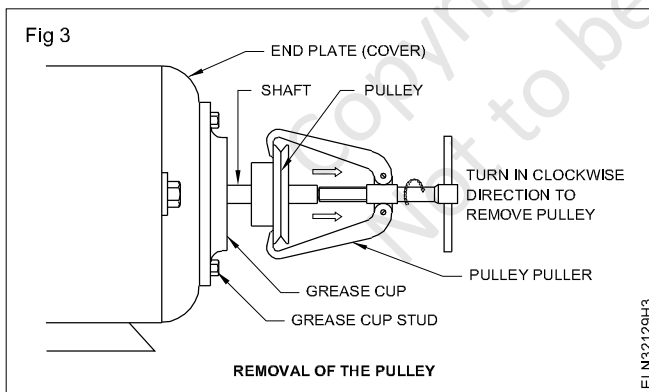

9 Remove the grease cup stud and open the grease cup. (Fig 4)

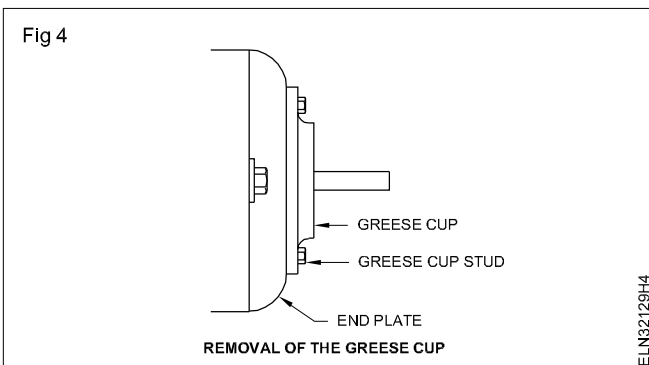

The screws, studs, bolts and nuts removed from the machine must be immersed in kerosene to remove the rust and dirt.

10 Loosen the studs of both the end plates and then remove the end plate of the shaft side.

Slowly open one end of the end plate, holding the armature shaft by hand or pulley block so that the weight of the armature does not damage the pole faces or field windings.

11 Remove the armature from the body of the machine. (Fig 5)

12 Check the bearings for wear and tear, breakage or stall.

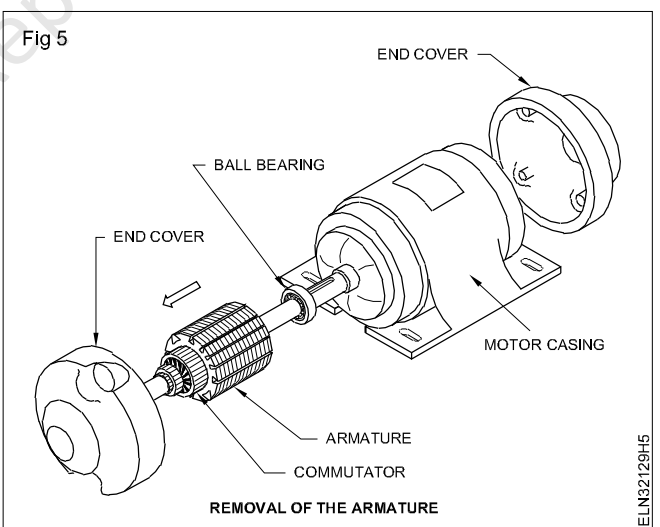

13 Remove the bearings using a bearing puller. (Fig 6)

14 Clean the bearings. (Fig 7)

Replace the bearings, if found defective.

15 Grease the bearings and cover with plastic paper. (Fig 7)

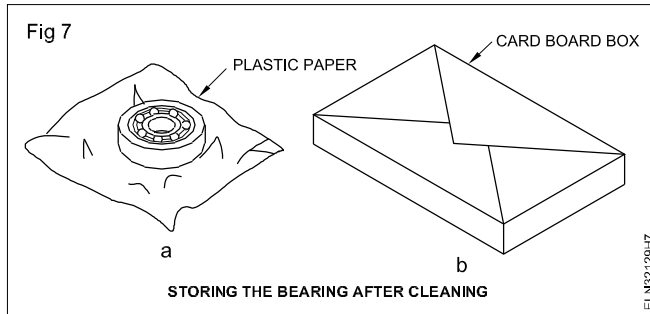
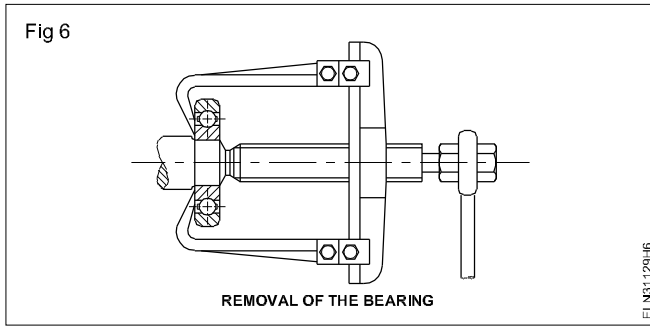

New bearings need no cleaning. Do not remove the new bearings from the package until needed. Before opening the new bearing, keep the workbench clean and tidy. For fixing the bearing in the shaft, follow the guidelines (Fig 8).

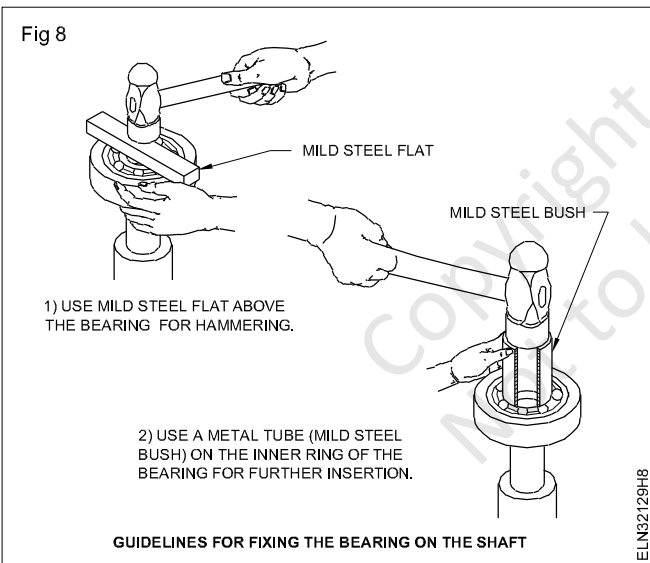

- 16 Clean the yoke and armature with a brush and air blower.
- 17 Test the armature with a growler.
- 18 Reassemble the yoke, armature and end plates.
- 19 Check the freeness of the shaft by rotating the shaft by hand.

If found tight (not free) loosen the end-plate studs and tighten the crosswise studs gradually in the proper sequence, and at the same time feeling the shaft for free rotation.

- 20 Insert the brush in the holder, adjust the brush tension, and bed the brushes following the procedure. (Fig 9)

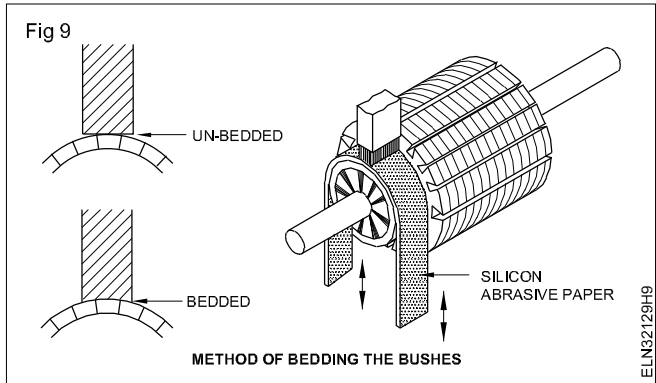

- 21 Position the rocker-arm in the end plates as per original marking.
- 22 Check whether the motor is operating smoothly without any vibration. A check-list for mechanical functions is given in Table 4. Fill up all the possible columns after checking the motor operation.
- 23 Connect the voltmeter, ammeter and the motor to the rated supply voltage and measure the no-load current, terminal voltage and r.p.m.

Table 4

Sl. No.	Check-list (Mechanical)	Remarks
1	Noise	
2	End-play	
3	Rotor running free	
4	Bearing fits	
5	Lubrication, grease, nipples oil supply	
6	Temperature bearings	
7	Temperature motor frame	
8	Condition of shaft, keyway, pulley, bearing seals	
9	Bolts, nuts tightened	
10	Test run 30 min	

Perform DC machine winding by developing connecting diagram, test on growler and assemble

Objectives: At the end of this exercise you shall be able to

- **dismantle the armature from the body**
- **collect and record the armature datas**
- **test the armature for ground with test lamp**
- **test the armature for short in the coil with an external growler**
- **test the armature for open in the coil with an external growler.**

Requirements	
<p>Tools/Instruments</p> <ul style="list-style-type: none"> • Electrician tool kit - 1 Set • Insulated cutting pliers 200mm - 1 No. • Scissors 150 mm - 1 No. • Mallet hardwood 0.5kg - 1 No. • Soldering iron 25W, 125W, 240 V - 1 No. • Tray 200 mm x 200 mm x 50 mm - 1 No. • Scale with weights 1 to 450 g - 1 No. • Outside micrometer 0-25mm - 1 No. • Tweezer 100mm - 1 No. • Stand winder for armature - 1 No. • Power hack saw blade used - 1 No. • Centre punch 150mm - 1 No. <p>Equipment/Machines</p> <ul style="list-style-type: none"> • Growler external with hacksaw blade - 1 No. • Burnt out armature - 1 No. • Rotor balancing machine for small armature - 1 No. • Multimeter 0 1000 ohm 2.5 to 500V - 1 No. 	<p>Materials</p> <ul style="list-style-type: none"> • 7 Mill millinex paper - as reqd. • 30 SWG super-enamelled copper wire - 300 g • Empire sleeve 1mm, 2mm - 1 m each • Cotton tape 20mm - 1 m • Binding/hemp thread - 1 roll • Hylam/fibre wedge 2mm thick - as reqd. • 10 milli triplex paper - as reqd. • V-32 insulation varnish - 1/2 litre • Thinner - 1/2 litre • Resin core solder 60/40 - 20 g • Resin flux (power type) - 10 g • Air dry varnish - 1/2 litre • Used hack saw blade - 1 No. • Soldering paste - 10 g

PROCEDURE

TASK 1: Dismantle of armature from the body

Assumption: To facilitate easy approach, the procedural steps are for a mixer similar to Sumeet make. However NIMI does not take any responsibility for the correctness of the specification given in this information as the specifications are bound to change by the manufacturer from time to time.

- 1 Note the name-plate details of the given mixer in Table 1.
- 2 By turning the mixer upside down, make the position of the closing cover.
- 3 Dismatle the rubber bush and unscrew the fixing screw from the closing cover.
- 4 Trace the main supply lead and its connection to the internal parts.

- 5 Trace the internal connection from the field, armature, speed selector switch and draw the connection diagram.

Fig 1 is given for your guidance.

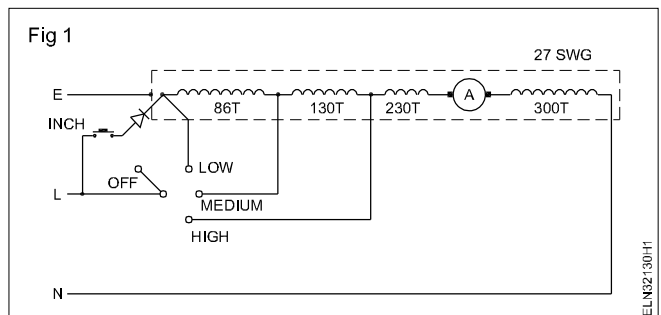

Table 1
Data Sheet

Make		Type.....							
KW.....		Volt		Amp.....		No. of poles.....			
		R.p.m.....		Frame.....		Model.....			
Rotor	Size of wire	No. of Turns	Coil Pitch	Coils/Slot	Wt. of one coil	Wt. of the winding	No. of slots	No. of commutator	Remarks
Centre of slots. to Centre of bars Centre of mica						<div style="border: 1px solid black; padding: 5px;"> <p align="center">Fig 2</p> </div>			
Commutator									
Pitch									
Lap Wave									

- | | |
|--|---|
| <p>6 Remove the top cover screw which is fitted in the inner side of the body of the mixer.</p> <p>7 Remove the top cover of the mixer.</p> <p>8 Remove the coupling pulley</p> <p>9 Disconnect the main supply lead and inner leads from the speed selector switch terminals.</p> <p>10 Remove the motor from the plastic cover assembly.</p> | <p>11 Remove the carbon brushes.</p> <p>12 Mark the position of the bottom cover and the body for the mixer with the help of a centre punch.</p> <p>13 Loose the through machine screw and remove the bottom cover.</p> <p>14 Remove the fan blade from the armature shaft.</p> <p>15 Remove the armature out of the stator</p> |
|--|---|

TASK 2: Collect and record the armature datas

- 1 Check visually the armature for fault symptoms and then by an external growler.
- 2 Note down your findings in Tables 1 under symptoms of defects
- 3 Place the armature in the winding stand. Count the number of slots, number of segments and record in Table 1.
- 4 Draw the developed diagram with the help of the data obtained.

To give proper guidance to the trainees a particular make mixer (similar to sumeet mixer) is considered here.

The connection diagram is shown in Fig 3, the ring diagram is shown in Fig 4 and the developed diagram is shown in Fig 5.

- 5 Identify one slot and mark a dot each on the side of slot with the help of a centre punch. (Fig 6)
- 6 Trace the end connection from the slot to the commutator segment.

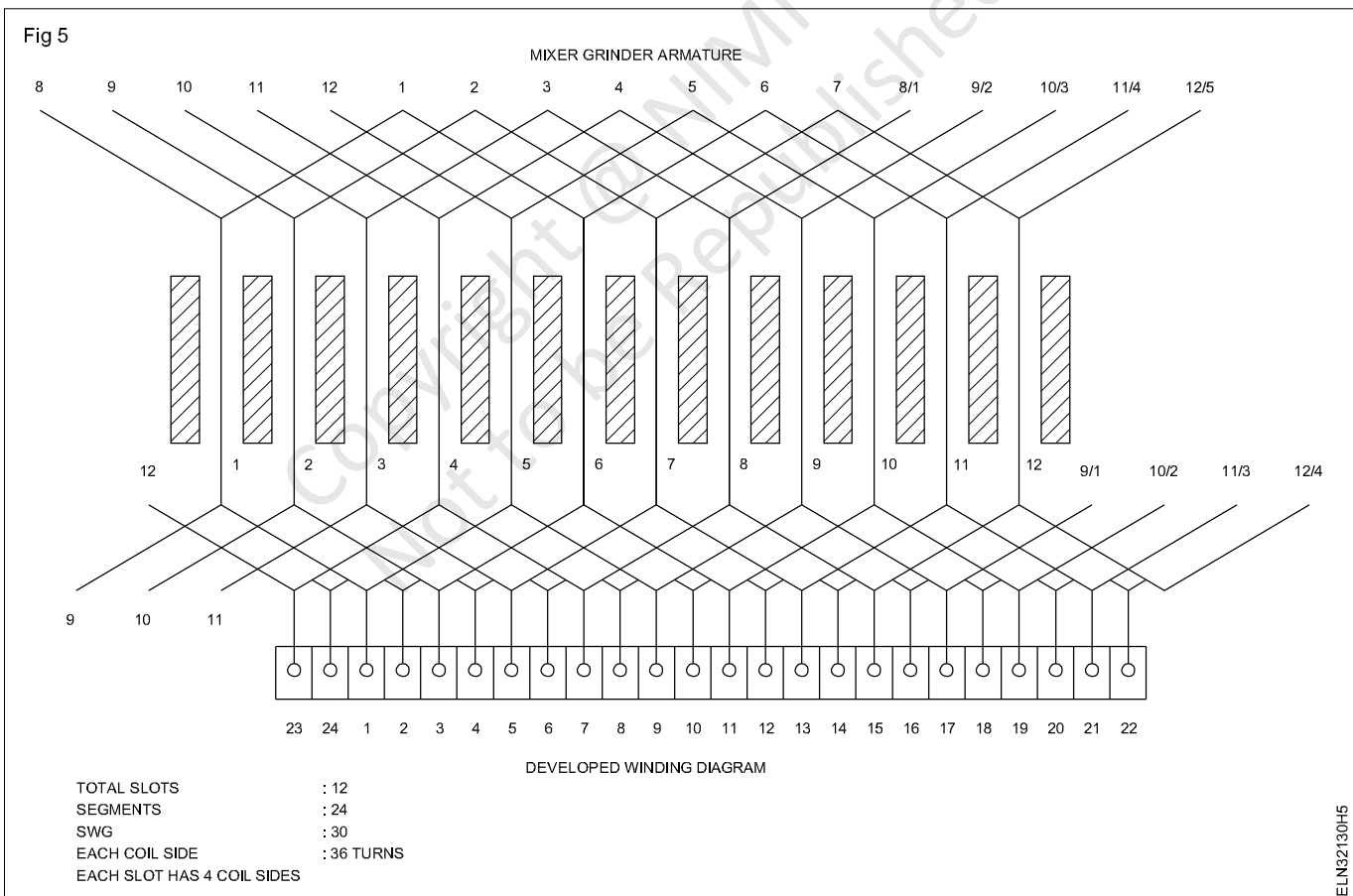
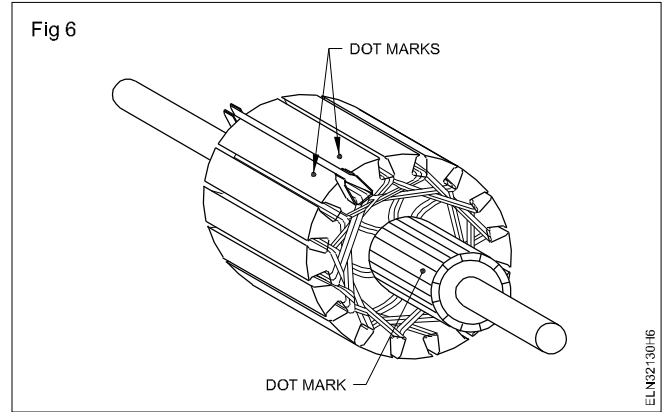
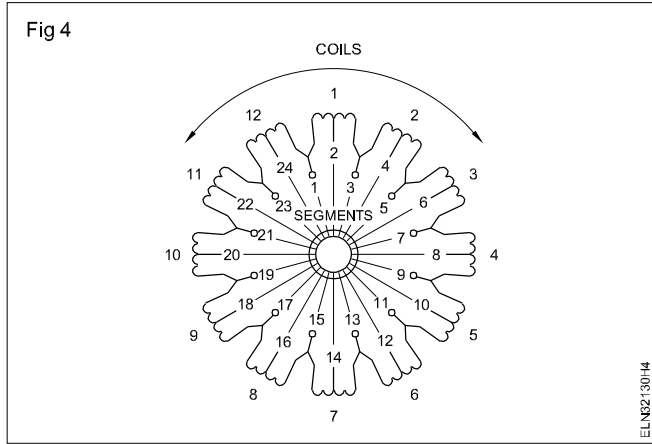
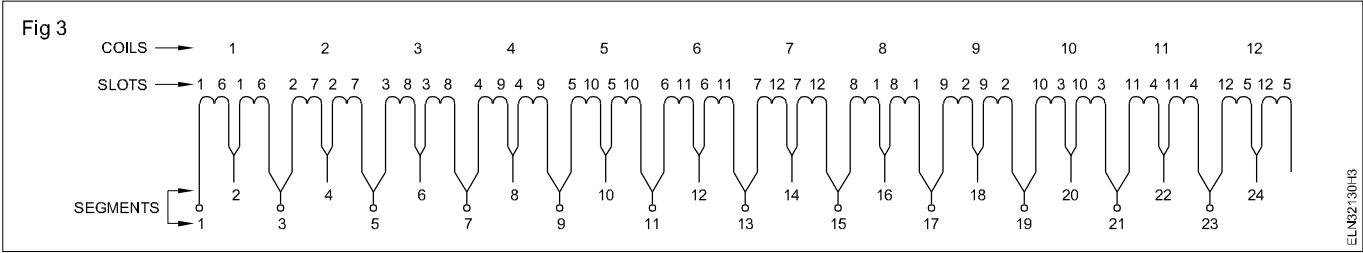

7 Mark one dot on the lightly ends of the identified commutator segment by using a centre punch. (Fig 6)

Fig 7 shows the lead swing as found in the mixer taken as the example

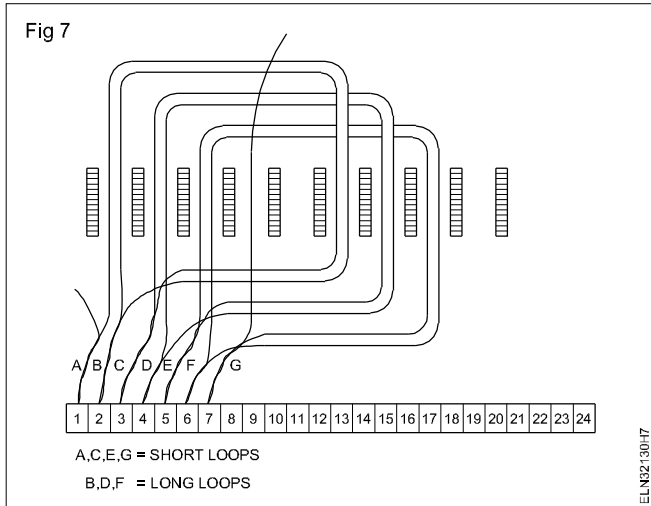

- 8 Record the findings in Table. 1
- 9 Cut the armature leads from the commutator raisers.
- 10 Apply a thinner to the armature slots and winding.
- 11 Remove the fibre/Hylam wedges from the armature slots (Fig 8).
- 12 Count the coil pitch and record it in Table. 1

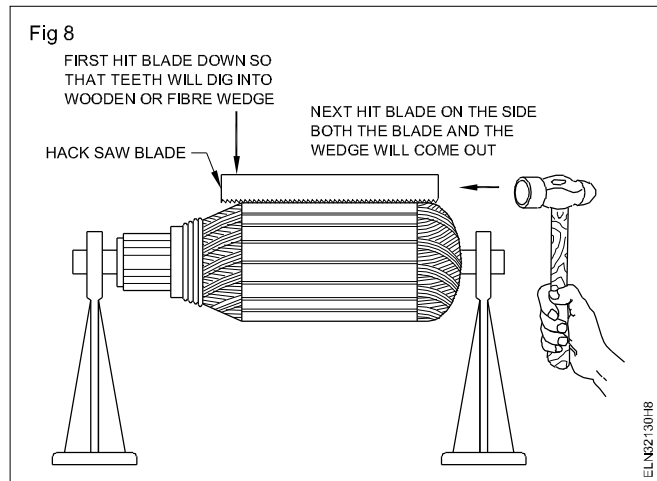

- 13 Remove the armature coil one by one from the slots
- 14 Count the number of turns, size of winding wires weight of each coil, weight of whole winding and type of slot insulation. Record them in Table 1.
- 15 Practice the exercise for three or four times with different armature assemblies.
- 16 Keep all the parts safely for using at the next exercise.

TASK 3: Perform winding of armature

- 1 Select the winding wire according to the original winding and mount the spool on a stand.

For sumeet mixer use winding wire of size 30SWG.

- 2 Insert a guide paper in the identified slots in which the coil is to be placed. (Fig 9)

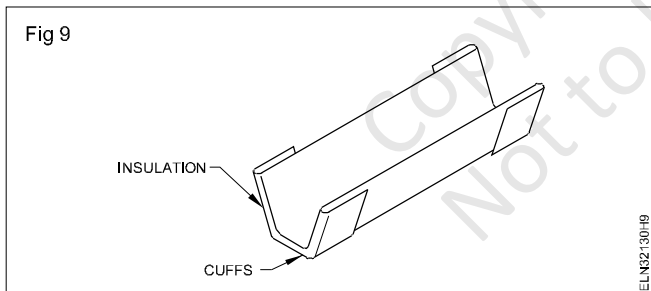

For the sumeet mixer, taken as an example, we have

Total number of slots = 12
Segments = 24
Winding wire = 30 SWG
Number of coil sides in each slot = 4

(2 coil sides are looped together and the loops are connected to the segments)

Number of turns in each coil = 36 turns identified slot pitch 1-6.

- 3 Place a guide paper in slots 1 and 6. (Fig 9)
- 4 Hold the armature in hand. (Fig 10)

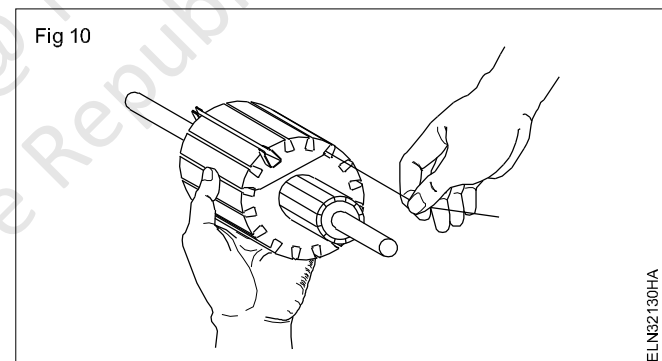

Large size armatures are to be supported by stands (horses during winding). (Fig 11)

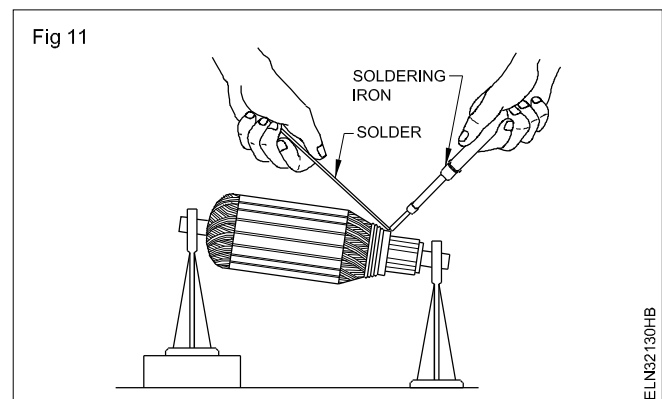

- 5 Wind the armature by hand placing one end of the coil side in slot No.1 and the other in slot No.6
- 6 Count 36 turns and then make a longer loop.

Do not make mistakes in counting. Wrong number of turns will result in unbalanced armature.

- 7 Make another 36 turns in the same solts (1 and 6) by holding the loop with your fingers of the hand.

- 8 Make a short loop at the end of the second coil and start winding the next coil in slot numbers 2 and 7.
- 9 Make a long loop at the end of 36 turns and wind the same number (36) of turns in the same slots (2 and 7).

TASK 4: Solder the armature after rewinding

- 1 Measure the lead swing length so as to reach the identified commutator raisers.
- 2 Remove the insulation of the winding wire loops at the connection points to the raisers.
- 3 Place the end connection wires in the risers in proper sequence and tie a rubber band on the commutator so as to hold the extended wire connections from the raisers in position.
- 4 Solder the end connections with the raisers properly (Fig 11).
- 5 Remove the excess solder from the raisers.
- 6 Check the connections and then bind the end connections with the armature. (Fig 12)
- 7 Test the armature with an external growler for shorts, open and grounding.
- 8 Varnish the armature after no fault in armature.
- 9 Remove the excess varnish after drying and check the rotor for balance in a dynamic balancing machine.
- 10 Assemble the mixer/liquidizer and test run the mixer with load.

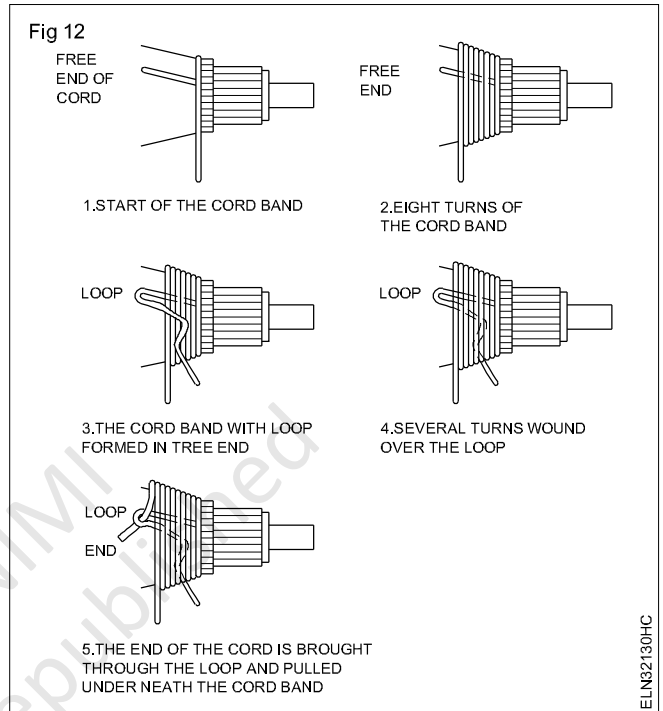

TASK 5: Test the armature

- 1 Test the armature winding for ground with a test lamp between the commutator segments and shaft. (Fig 13)

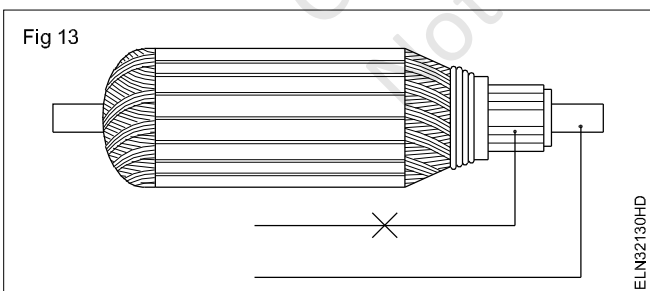

In case of grounding, trace the grounding by sequential de-soldering of the commutator connections and remove the grounding.

- 2 Place the armature on the external growler. (Fig 14)
- 3 Switch 'ON' the growler.
- 4 Hold the hacksaw blade over the top of the slot and along the length of it. (Fig 15)

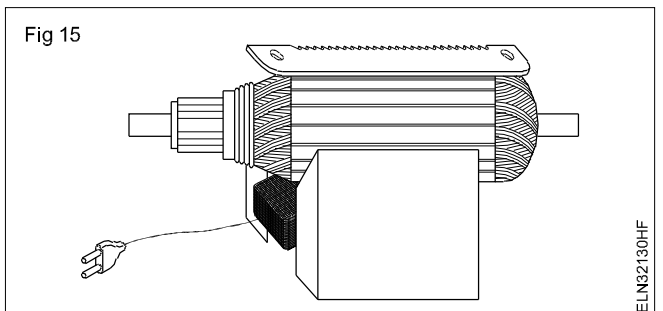
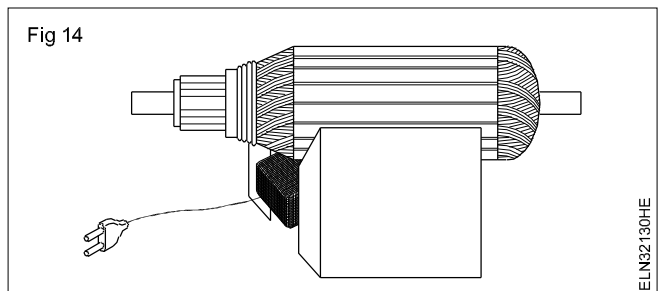

- 5 Rotate the armature slowly and observe the hacksaw blade vibration and the growling noise.
 - The blade does not vibrate-it is an indication of 'NO' short in the armature coils.
 - Vibration of the blade and a growling noise indicate short in the coil.

In case of a fault, rectify the same.

- 6 Connect the AC milli-volmeter/ammeter (normally provided with the growler) leads to the top two adjacent segments (Fig 16) by keeping the growler switches 'ON'.

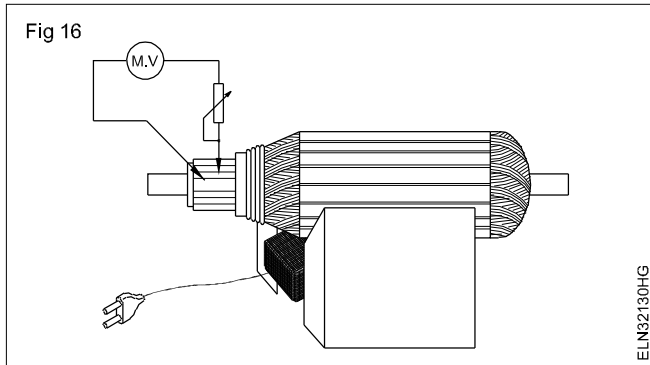

- 7 Rotate the armature and continue testing all the adjacent bars.

While rotating the armature, the geometrical position of the test-leads should not be changed for subsequent testings.

- Equal meter reading show correctness of winding.
 - Any higher value of reading shows open in-between the armature coil/coils
- 8 Consult the instructor in case of fault in the armature winding.
 - 9 Pre-heat and varnish the armature.

Care should be taken while varnishing the armature to ensure that the commutator is not exposed to the varnish.

- 10 Repeat the exercise for four or five armatures.

Identify parts and terminals of three phase AC motors

Objectives: At the end of this exercise you shall be able to

- read and interpret the name plate details of the given 3 phase squirrel cage induction motor and slipping induction motor
- identify their parts and write their names
- test the 3 phase squirrel cage induction motor for continuity test
- identify the terminals of 3-phase squirrel cage and slipping induction motors.

Requirements			
Tools/Instruments		Equipments/Machinery	
• Insulated combination plier 200mm	- 1 No.	• AC 3 phase squirrel cage induction motor - 5HP, 3-Phase, 415V, 50Hz	- 1 No.
• Insulated screw driver 200mm with 4mm blade	- 1 No.	• AC 3 phase slip ring induction motor - 5HP, 3-Phase, 415V, 50Hz	- 1 No.
• DE spanner set 5 mm to 20mm	- 1 Set	Materials	
• MI volt meter 0-300 V	- 1 No.	• PVC Insulated copper cable 1.5 sq mm	- 4 m
• MI volt meter 0-500 V	- 1 No.	• Pendent lamp-holder 240V 6A	- 2 No.
• Test lamp 240V, 60 Watts	- 2 Nos.		

PROCEDURE

TASK 1: Identify the parts of 3 phase squirrel cage induction motor

Instructor may arrange the AC 3 phase squirrel cage induction motor and slip ring induction motor in dismantled condition on the work bench. Explain the name of the parts and label them with numbers. Then ask the trainees to write the name of the parts for the labelled number parts. (or)

If the dismantled motors are not available provide the exploded view chart of the motor and hide the parts name, and explain and ask them to write their names.

- 1 Read and interpret the name plate details of the 3 phase squirrel cage induction motor and note down in Table 1

Table 1

Name-plate details

Manufacturer, Trade Mark.....	Rated frequency.....Hz
Type or model or	Rated power.....k.w/HP
Type of current.....	Rating class.....
Function.....	Insulation class.....
Serial number.....	Rated current.....Amps
Type of connection.....	Rated speed.....r.p.m
Rated voltage..... volts	Protection class.....

- 2 Identify the parts of the AC squirrel cage induction motor from the real objects or from the exploded view chart (Fig 1)
- 3 Label the each identified parts with number tags.
- 4 Write the name of the parts of each labelled number tag in Table 2
- 5 Get it checked with your instructor.

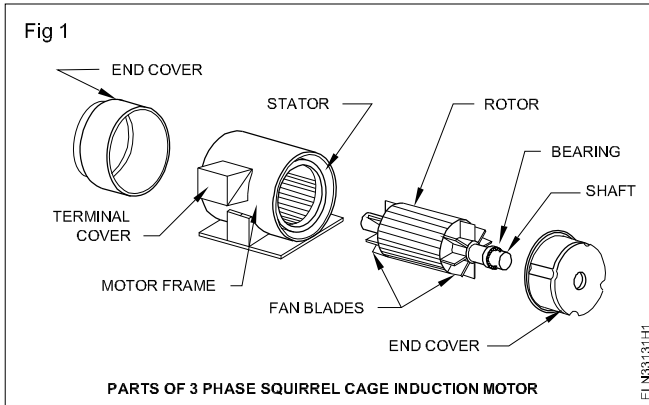

Table 2

S. No.	Label Number	Name of the parts of squirrel cage induction motor
1		
2		
3		
4		
5		
6		
7		

TASK 2: Identify the parts of AC 3 Phase slip ring induction motor

1 Read and interpret the name plate details of the 3 Phase slip ring induction motor and note down in Table 3.

Table 3

Name-plate details

Manufacturer, Trade Mark.....	Rated frequency.....Hz
Type or model or	Rated power.....k.w/HP
Type of current.....	Rating class.....
Function.....	Insulation class.....
Serial number.....	Rated current.....Amps
Type of connection.....	Rated speed.....r.p.m
Rated voltage..... volts	Protection class.....

2 Identify the parts of the AC 3 Phase slip ring induction motor from the real objects (or) from the exploded view chart (Fig 2).

Table 4

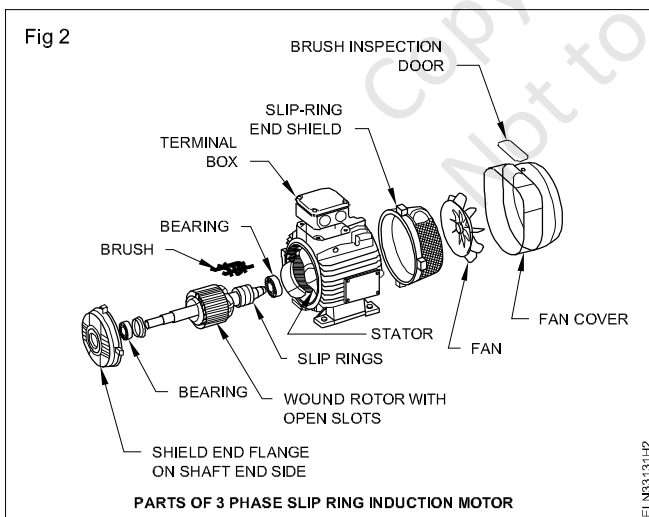

S. No.	Label No.	Name of the part
1		
2		
3		
4		
5		
6		
7		
8		
9		
10		
11		
12		

3 Label the each identified parts with number tags

4 Write the name of the parts of each labelled number tags in Table 4.

5 Get it checked with your instructor.

TASK 3: Identify the terminal of a 3 phase squirrel cage induction motor

METHOD 1: Identifying the terminals of a 3-phase induction motor with the help of two lamps in series

Lamps should be equally rated both in voltage and wattage. (Fig 3)

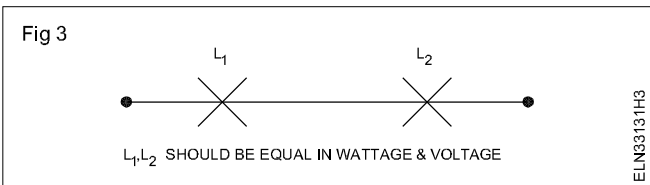

- 2 Test for continuity with the help of a test lamp and find the 3 pairs out of six terminals of the induction motor. (Fig 4)

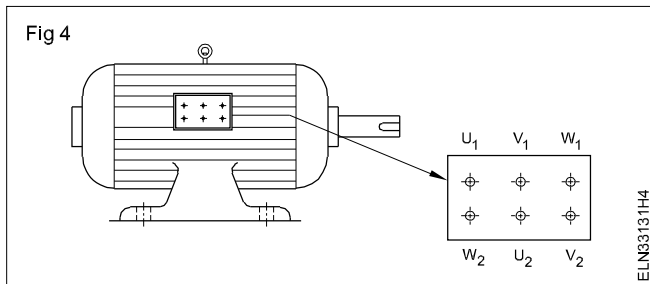

- 3 Identify the 3 pairs of terminals, name them as 'U' coil, 'V' coil and 'W' coil.
- 4 Tag U_1 and U_2 for 'U' coil only. For other coils tag V_1 and V_2 for 'V' coil and W_1 and W_2 for 'W' coil as shown in Fig 3.

Assuming the terminal marked as U_1 by you is the beginning of coil U, proceed as below.

- 5 Connect the terminals U_1 to V and then connect the series combination of the lamps to the winding ends U_2 and V as shown in Fig 5a and give 250 AC voltage across U_1 and U_2 .

If the lamps glow bright as shown in Fig 5a then the linked ends are similar ends. For example, the linked ends are U_1 and V_1 .

If the lamps glow dim as shown in Fig 5b, then the linked ends are dissimilar ends. For example, the linked ends are U_1 and V_2 .

- 6 Check to the test result in step 6 or 7, mark the name of V coil terminals as V_1 and V_2 .

When the current flows through the coils they produce magnetic fields. If similar ends are connected, the magnetic fields help each other and produce high voltage across the lamp terminals making them to glow bright. In the case of dissimilar connections the voltage at lamp terminals will be low and the lamps will give dim light.

- 7 Test in the same way for the remaining terminals of coil 'W' and mark them as W_1 and W_2 .

METHOD 2: Identifying the terminals of a 3-phase induction motor with the help of a voltmeter

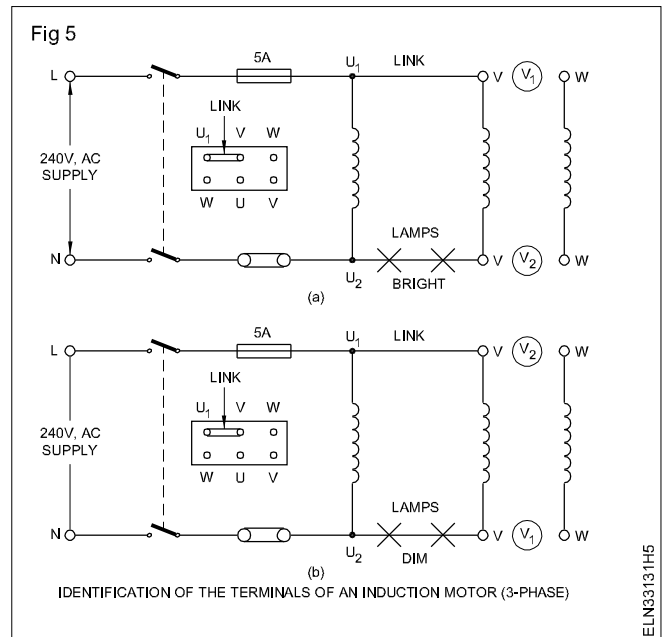

- 1 Repeat the steps 1 to 4 of Method 1.
- 2 Connect the terminals U_1 and V with a link, connect a voltmeter V_L of 500V range between U_2 and V and a voltmeter V_P of 300V range between U_1 and U_2 as shown in Fig 6.

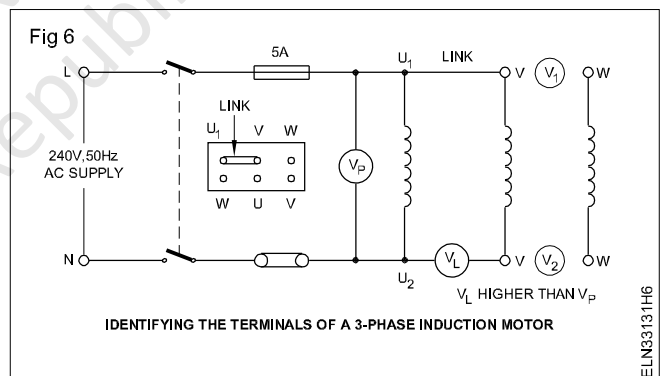

- 3 Switch 'on' the supply, if the voltmeter V_L reads more than V_P , then the linked terminals are similar as shown in Fig 4 (i.e U_1 and V_1).
- 4 Check the voltmeter V_L reads less than V_P , then the linked terminals are dissimilar (i.e U_1 and V_2). Mark them as U_1 and V_2 .
- 5 Test in the same way the remaining terminals of coil 'W' and mark them as W_1 and W_2 .

Normally small capacity, 3-phase induction motor terminals are arranged in the terminal box as shown in Fig 2 to facilitate either star or delta connection to be made in the terminal box itself by links and to be started by a D.O.L starter. Compare your terminal marking with the terminal marking given on the terminal plate. Discuss with your instructor and seek further clarification if there is any difference.

METHOD 3: Identifying the terminals of a 3-phase induction motor with the help of single lamp method

- 1 Connect the terminals as shown in Fig 7a. Connect it to a 240V AC supply and switch on the supply.
- 2 Check the lamp glows, the linked terminals are dissimilar. i.e U_2V_1 . Mark them as U_2V_1 .

If the lamp does not glow, the linked terminals are similar (i.e U_2V_2). (Fig 7b) Mark them as U_2 and V_2 .

When current flows through the coils they produce magnetic fields. If dissimilar ends are shorted (linked) they assist each other and voltage induces in the third coil and the lamp glows. If similar ends are linked, the magnetic fields oppose each other and no voltage will be induced in the third coil. Hence the lamp does not glow.

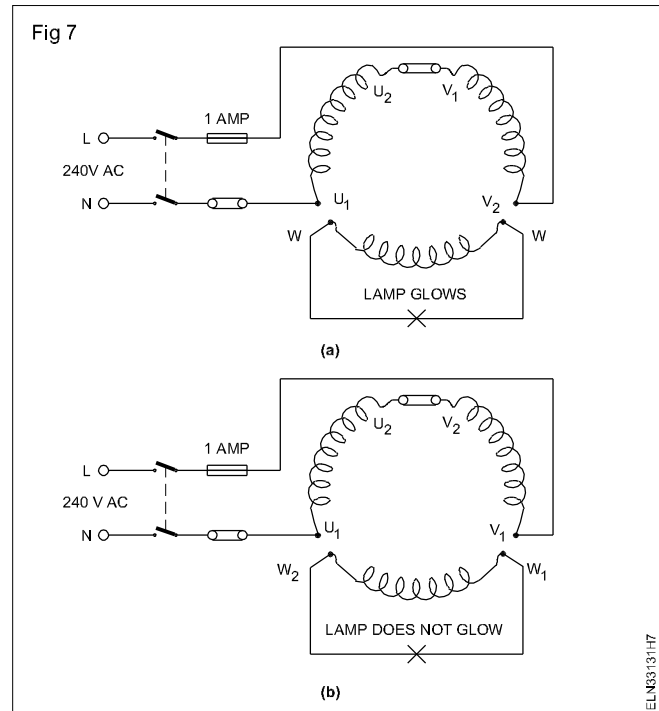

TASK 4: Identify the terminal of a slip ring induction motor

- 1 Remove the terminal box cover and sketch the layout of the terminals. (Fig 8)

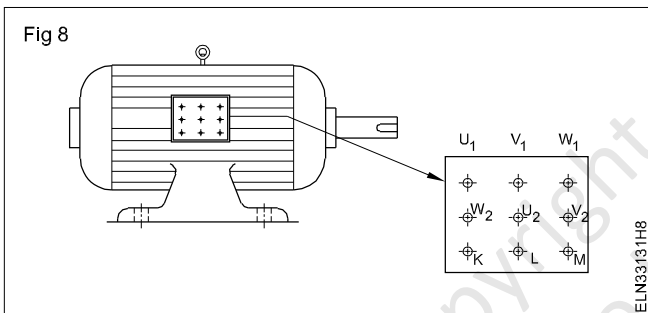

- 2 Test for continuity with the help of a test lamp and find out rotor's three terminals out of nine terminals of the slip ring induction motor
- 3 Connect prob - 1 to any one of the 3 slip rings or brush
- 4 Touch prob - 2 to terminals of motor one by one.
- 5 Check the test lamp burns then that terminals are rotor terminal.
- 6 Put name them as KLM and remaining six terminals are stator terminals.

The above test will not be valid until and unless the following conditions are observed.

Condition 1: Check and ensure that the earth continuity conductor (E.C.C) connected to them main earth electrode is in perfect continuity, having a resistance of less than 1 Ohm.

Condition 2: The resistance of the earth electrode should be less than 5 ohms unless otherwise stated.

- 8 Draw connection diagram for the 3 phase slip ring induction motor (Fig 9).

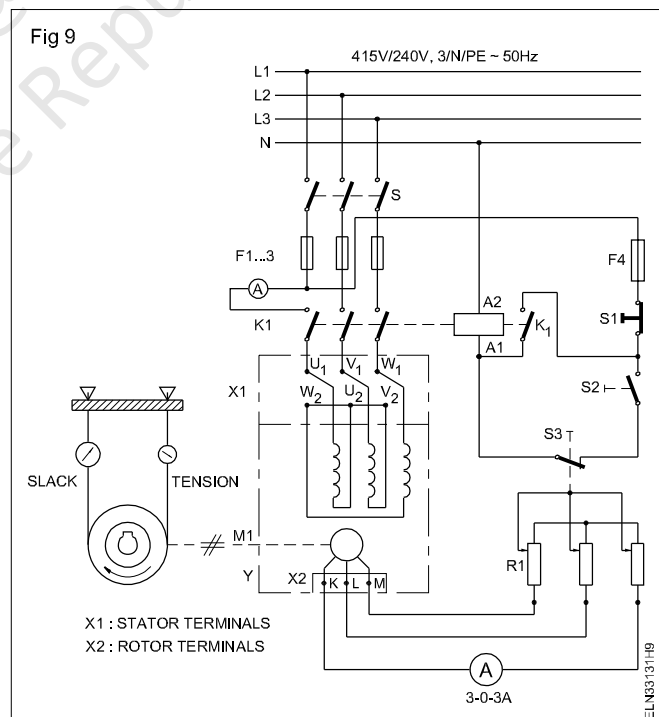

Make an internal connection of automatic star-delta starter with three contactors

Objectives : At the end of this exercise you shall be able to

- identify the major parts of semi automatic and automatic star delta starter
- read and trace the internal circuit diagram of the both starter
- make internal connections of a semi-automatic starter and automatic starter between contactors timer start-stop push button and over load relay
- check for the functioning of the starter no volt release
- connect the squirrel cage induction motor to starter
- set the timer unit in an automatic starter with appropriate timing.

Requirements			
Tools/Instruments		Materials	
• Connector /Screw driver 100 mm	- 1 No.	• PVC insulated copper wire 2.5 sq mm, 250V grade	- as reqd.
• Spanner Set (6mm -25mm)	- 1 Set	• Cleaning brush 3 cm dia	- 1 No.
• Multimeter	- 1 No.	• Carbon tetra chloride (CTC)	- 5 0 ml.
Equipment/Machines		• Grease type and quantity	- as reqd.
• Semi automatic star-delta starter 10A 415v,50Hz	- 1 No.	• Kerosene	- 1 litre
• Automatic star-delta starter 10 A 415v to 50 Hz	- 1 No.	• Lurbication oil type and quantity	- as reqd.
• 3 Phase 415V 3 Hp/5 Hp squirrel cage induction motor with 6 terminals	- 1 No.	• Cotton cloth	- as reqd.
		• Sand paper/sand cloth-grade and quantity	- as reqd.
		• Solder 60/40	- as reqd.
		• Soldering flux	- as reqd.

PROCEDURE

TASK 1: Make the internal connection of the semi-automatic star-delta starter with three contactors

- 1 Collect the various components of a semi-automatic star-delta starter from the instructor (i.e Contactors, overload relay, start-stop-push-button etc.)
- 2 Name the external parts indicated by numbers. (Fig 1)

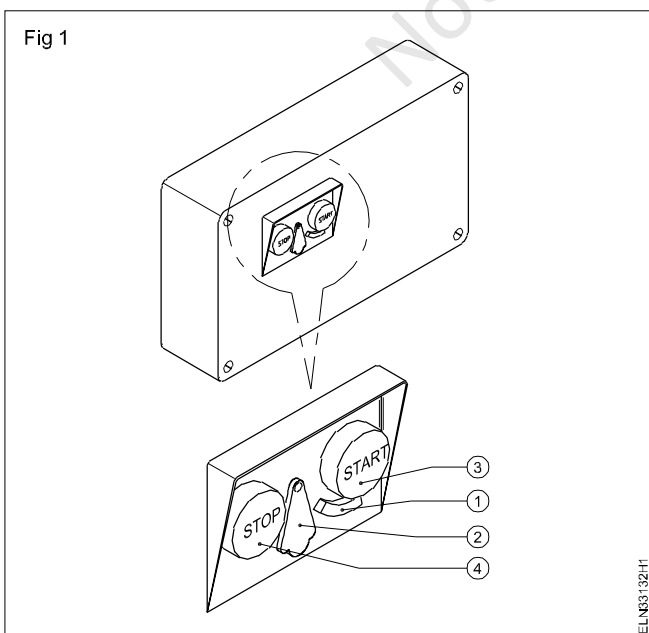

- 1
- 2
- 3
- 4
- 3 Draw and complete the connections in Fig 2 for the power circuit only confirming to Fig 5 (i.e connection between supply, contactors, overload relay and motor terminals).

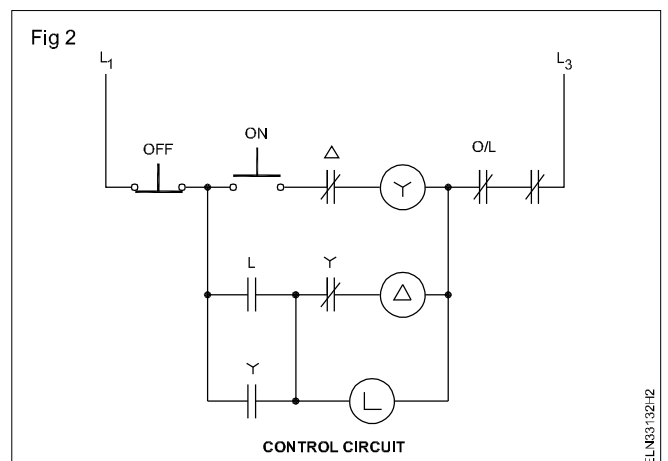

4 Read the control circuit diagram. (Fig 2) and draw the diagram (Fig 3) for semi automatic star-delta starter.

5 Open the cover of the semi-automatic star-delta starter. Read the circuit diagram given with it. (Fig 4 LT LK starter). Identify the major parts of semi-automatic star delta starter.

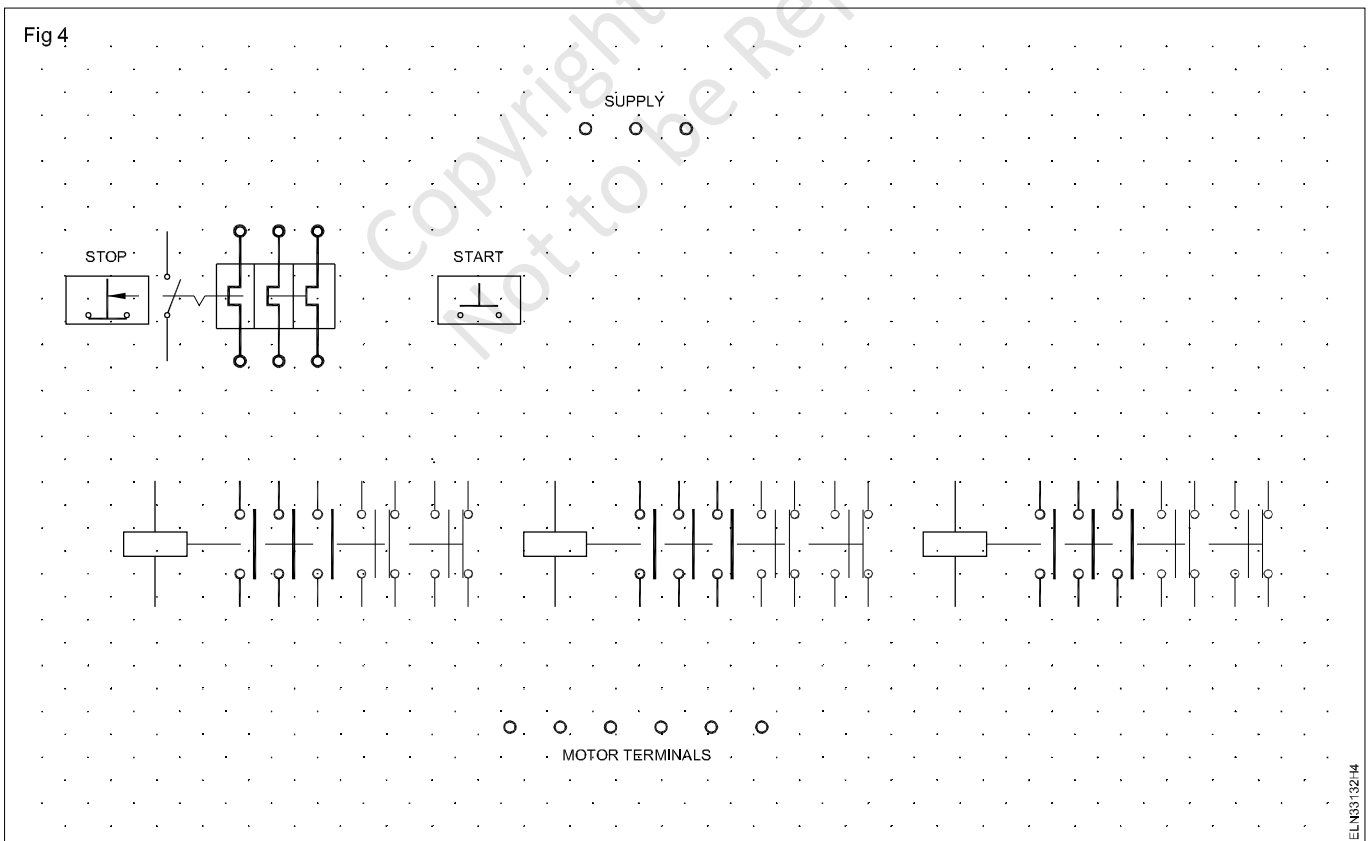
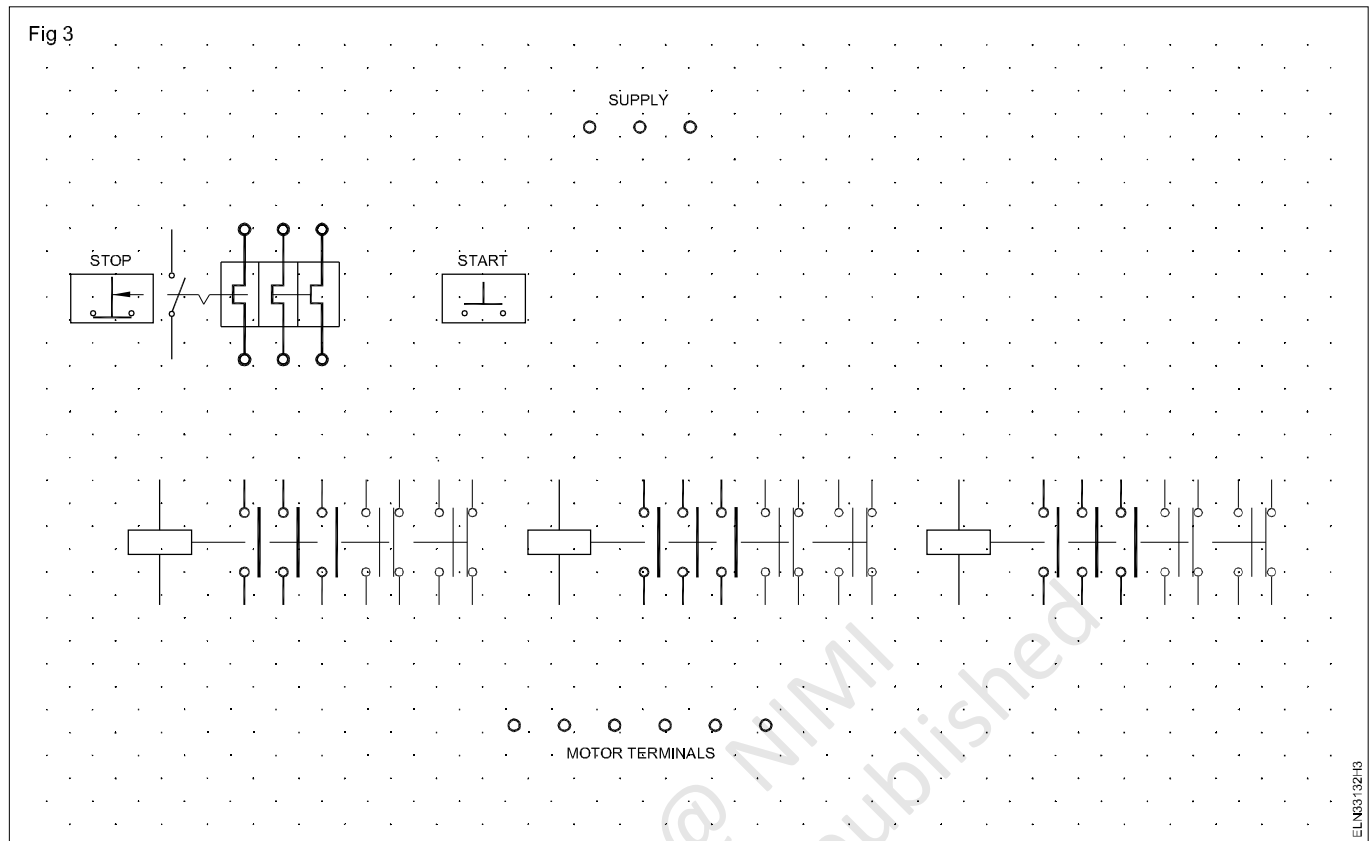

- 6 Check the working of the contactors with a multimeter by manually actuating the contactor.
- 7 Mount the contactors, overload relay etc. on a plain vertical board.
- 8 Name the contactors (i.e) main, star and delta.
- 9 Wireup the control circuit.

Use single strand conductors for control circuit connections. Make proper terminations.

- 10 Give supply to the control circuit and check for logical sequence of closing and opening the contactors.

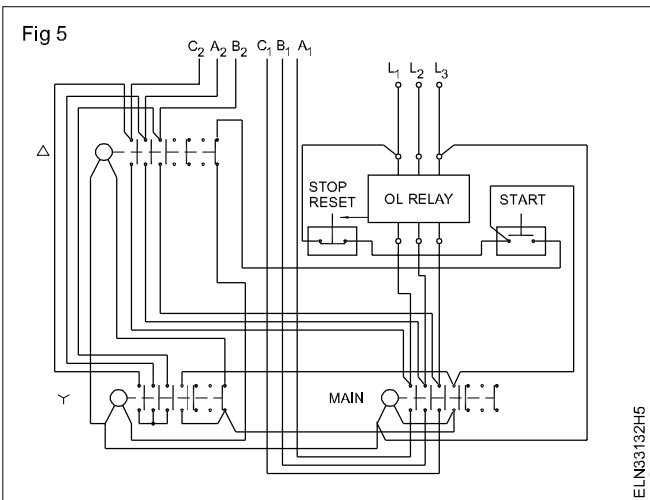

- 11 Call the instructor and get his approval to make the power circuit connections of the semi-automatic star-delta starter.

TASK 2 : Make internal connections of automatic star-delta starter with three contactors

- 1 Collect the automatic star-delta starter without inter connections from the instructor.
- 2 Name the external parts indicated by the numbers in Fig 6.

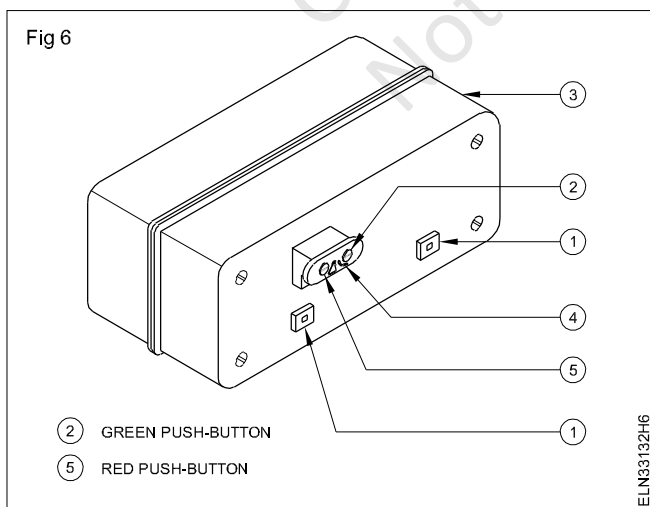

- 1
- 2
- 3

- 12 Wireup the power circuit for the semi-automatic star-delta starter according to the circuit diagram with the given starter.
- 13 Check the suitability of the starter for the given motor.
- 14 Connect the motor to the three phase supply through the semi-automatic star-delta starter.
- 15 Switch on the ICTP. Press the star-button of the starter. Observe the starting.

Check the fuse rating of ICTP which is suitable for the motor. Check the supply in all the phases.

- 16 Release the start-button and check the close and open condition of the contactors. When the motor reaches approximately 70% of the normal speed,
- 17 Press the start-button again and ensure there is no effect on the motor running.
- 18 Actuate the overload relay manually, and check its functioning.
- 19 Press the start-button to restart the motor. Record your observation.
The motor.....(fails to start/starts)
- 20 Record your findings for the motor not starting when the start-button is pressed immediately after overload relay tripping.

- 4
- 5
- 3 Name the internal parts of an automatic star-delta starter indicated in Fig 7.
1
- 2
- 3
- 4
- 4 Read the power and control diagrams (schematic) in Fig 8.
- 5 Draw and complete the connections in Fig 9 for power circuit only conforming to Fig 8 (i.e connection between supply, contactors, overload relay and motor terminals).
- 6 Draw the connections of the control circuit on the diagram provided (Fig 10) for automatic star-delta operation. Observe the sequence indicated in the schematic diagram. (Fig 8)
- 7 Open the cover of the automatic starter and read the circuit diagram given with it.
- 8 Check the working of the contactors with a multimeter by manually actuating the contactor.

Fig 7

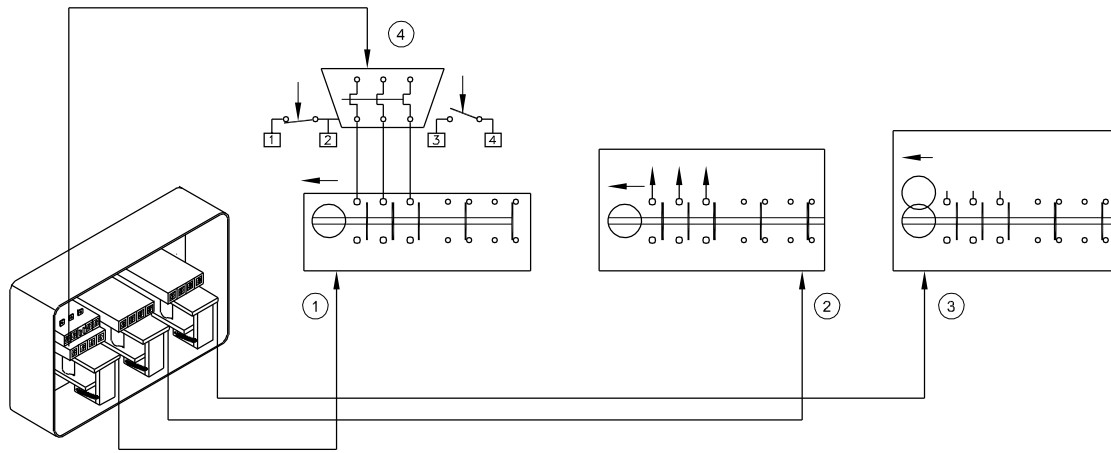

ELN33132H7

Fig 8

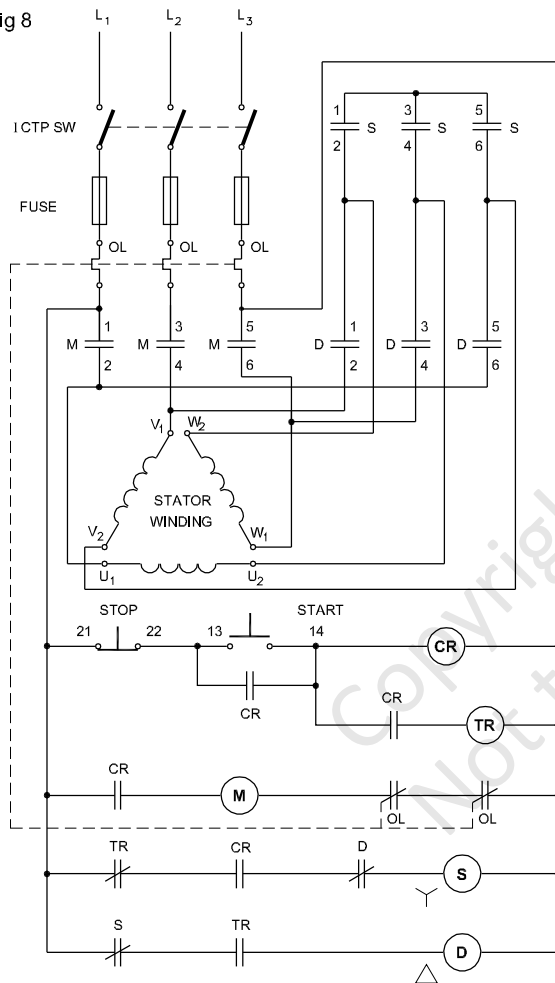

ELN33132H8

9 Mount the contactors, overload relay, stop and start push-buttons on the T.W board.

10 Wireup the control circuit with the help of connecting wires.

Use single strand conductors only. Make proper termination.

11 When separate contactors and other parts for an automatic star-delta starter are not available, remove the contactors, overload relay and the timer with the starter and mount on a plain vertical board for easy interconnections.

The space available within the starter is very limited and making connection consumes more time, and is a special skill of panel wiring.

12 Label the contactors, star, delta and main.

13 Give supply control circuit and check for the logical sequence of closing and opening contactors.

14 Call the instructor and get his approval to make the power circuit connections of the star-delta starter.

15 Wire up the power circuit on the star-delta starter according to the circuit diagram.

16 Read the name-plate details of the motor. Check the suitability of the fuse for the motor to be connected.

17 Connect the motor to the 3-phase supply through the starter.

18 Start the motor and observe the starting. Check what speed the starter switches over from the star to delta.

19 Answer the statement.

At what speed the switching over from star-y connection to Delta connection happens?

a) above 70% of normal speed

b) below 70% of normal speed

The turning of the set screw increases or decreases the gap between normal strip of timer relay causing more or less time to actuate contact mechanism.

20 Press the start-button again and check. There should not be any effect in the motor running.

21 Disconnect the motor from the supply after opening the ICTP isolating switch.

Fig 9

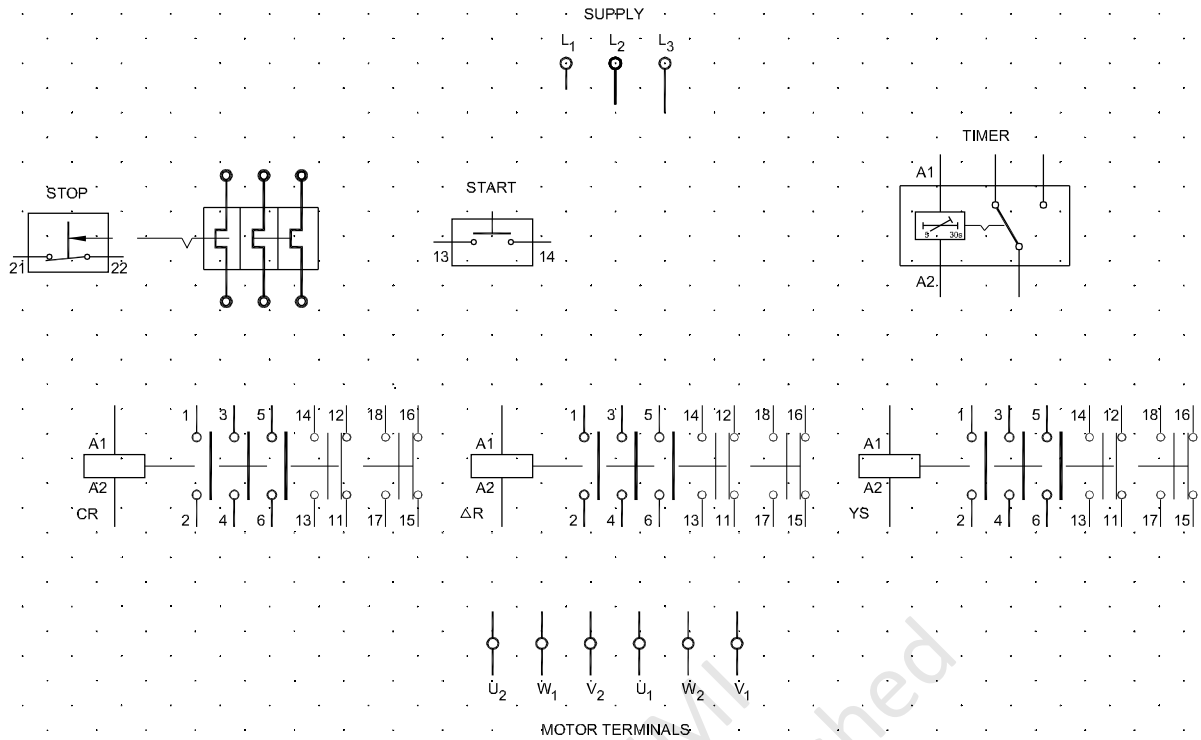

ELN3132H9

Fig 10

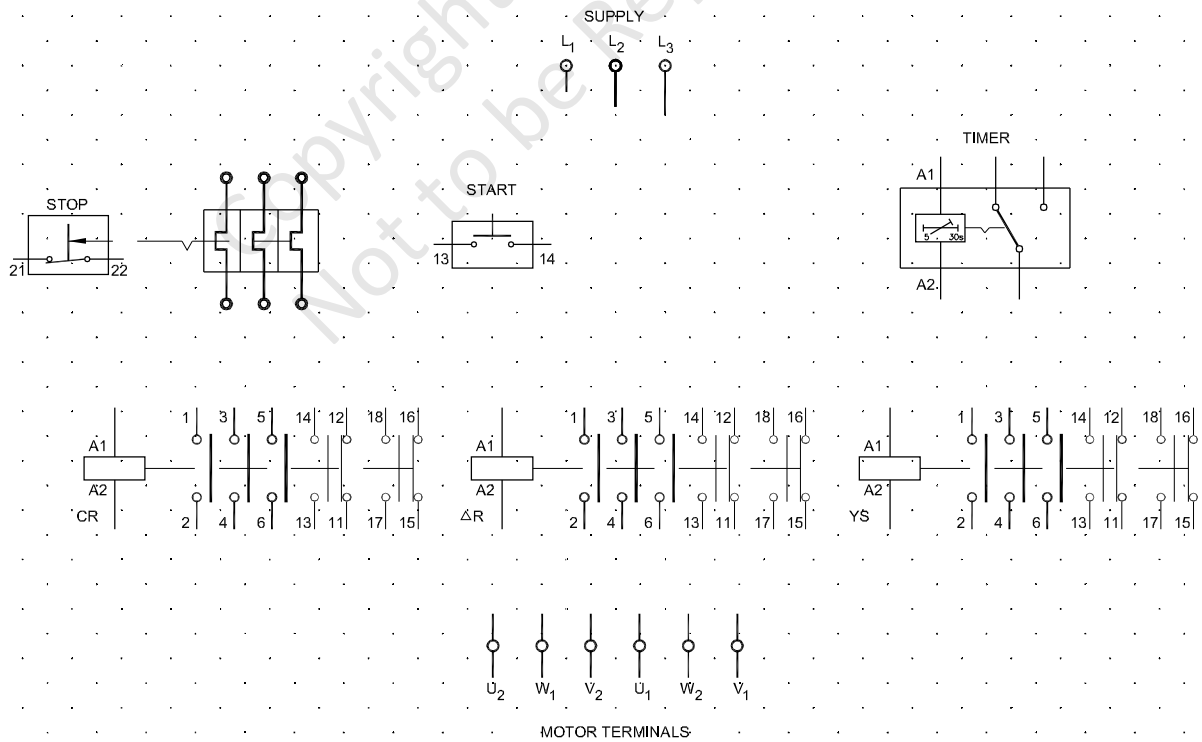

ELN3132HA

Connect, start and run three phase induction motor by using DOL, star-delta and auto transformer starters

Objectives: At the end of this exercise you shall be able to

- identify and collect the parts of a DOL starter
- assemble the DOL starter and make control circuit connection
- connect ICTP switch and DOL starter with 3 phase motor
- set the overload relay and replace correct capacity fuse
- start and stop the 3 phase motor through DOL starter
- Identify the parts of a manual star-delta starter and trace the connection
- connect the manual star delta starter with 3 phase squirrel cage motor
- adjust the over load relay according to the motor current rating
- start and stop the motor through the star delta starter
- reverse the direction of rotation of the motor
- connect a 3 phase induction motor with an auto transformer and contactor as starter
- start and run a 3 phase induction motor using auto transformer and contactor.

Requirements			
Tools/Instruments			
• Combination pliers 200 mm	-1 No.	• Delay time relay, 24V AC operating coil with 1 or 2 normally open contacts	- 3 No.
• Screw driver 200 mm, 300 mm	- 2 Nos.	• 3-phase Squirrel cage motor 415V, 50 Hz, 3HP, 5 HP	- 2 Nos.
• Connector screw driver 100 mm	- 1 No.	• DOL starter 10 Amp 415V	- 1 No.
• Wire stripper 150 mm	- 1 No.	• Manual star-delta starter 16A,415V	- 1 No.
• MI Ammeter 20A, 10A	- 2 Nos.	• TPIC switch 16A 415V	- 1 No.
• MI Volt meter 0-500V	- 1 No.		
• Tachometer 0-3000rpm	- 1 No.		
Equipment/Machines		Materials	
• Contactors 415V AC with 240V operating coil having 16A - 3 power circuit contacts 2A - 4 auxiliary change over contacts	- 4 Nos.	• PVC Insulated single strand copper cable 16 SWG, 18 SWG	- 0.5 m
		• Machine screw 2BA.30mm long with two washers and one nut	- as reqd.
		• Power cable single strand 2.5 mm ²	- as reqd.
		• GI wire 145WG	- 8 m

PROCEDURE

TASK 1: Identify the parts of a DOL starter connect, start and run the 3 phase induction motor

- 1 Note down the name-plate details of the given AC 3-phase squirrel cage induction motor in Table 1.
- 2 Collect the contactor unit, overload relay unit, start/stop push-button unit, the necessary fixing screws, hookup cables, I.C.T.P switch and D.O.L starter base and cover.

Table 1

Name plate details

Manufacturer, Trade Mark.....	Rated frequency.....
Type, model	Rated power.....k.w/HP
Serial number.....	Rated currentamps
Insulation class.....	Rated speed
Rated voltage.....volts	Protection class.....
Rated voltage..... volts	

- 3 List the items you received from your instructor in Table2.

Table2
List of items

1	_____
2	_____
3	_____
4	_____
5	_____
6	_____
7	_____
8	_____
9	_____
10	_____

- 4 Record the name plate details of the contactor and overload relay in your record respectively.
- 5 Investigate and check the contactor input and output terminals, auxiliary and main terminals, movable and fixed contacts, no-volt coil, overload relay, their rating, normally closed relay contacts and their operation.
- 6 Identify the connecting terminals for interconnecting no-volt coil, main supply to control circuit, normally open auxiliary contacts.

Refer and recapitulate the connection diagram

- 7 Identify the mounting screw holes in the contactor, overload relay and the corresponding holes in the starter base box.
- 8 Draw the complete circuit diagram for the given D.O.L starter with overload relay, no-volt coil, 'ON' and 'OFF' push-buttons.

For your guidance following diagrams are given for a starter of a particular make.

Fig 1 shows Base and cover of D.O.L starter.

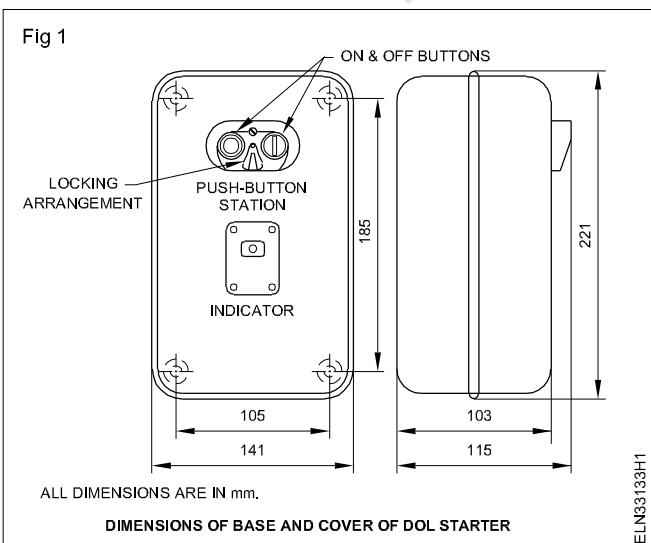

Fig 2 shows Push-buttons only.

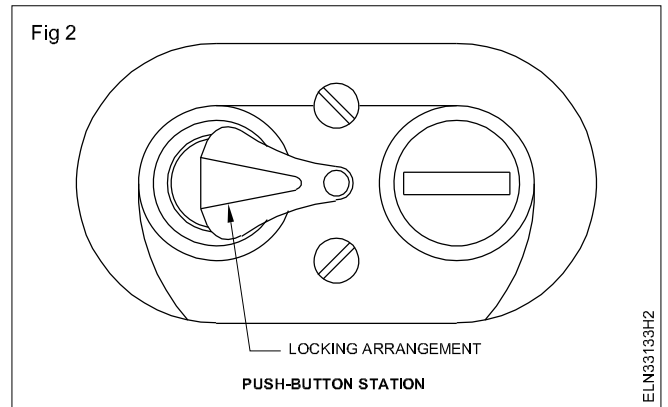

Fig 3 shows Overload relay package with push-button strips in the foreground which will get actuated when the push-buttons are pushed.

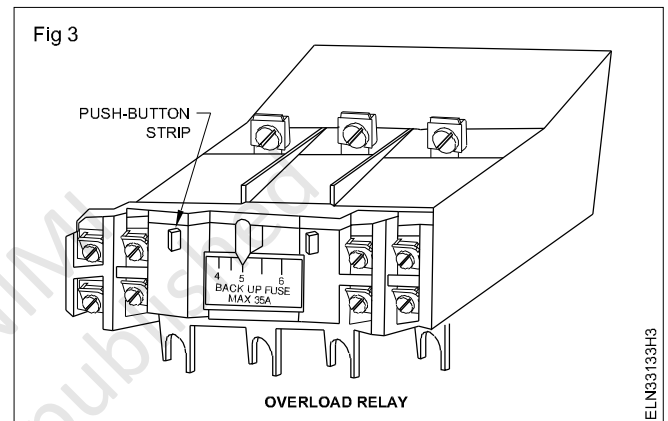
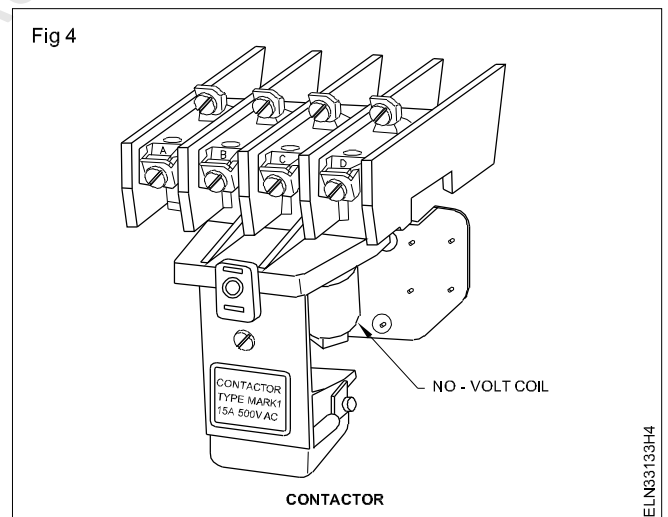

Fig 4 shows Contactor with no-volt coil.



- 9 Get the approval instructor for diagram.
- 10 Mount the accessories in the starter base box with the help of mounting screws.

Do not tighten the screws more than necessary as too much tightening of screws will break the PVC casing of the contactor and OL relay.

- 11 Identify the place of connection of the hook-up cables with the help of the approved diagram. Measure and cut the hook-up cables leaving allowance for harnessing.

- 12 Connect the hook-up cables according to the approved diagram.
- 13 Check harness of the hook-up cables such that the cables do not interfere with any moving mechanism of the starter.
- 14 Check up once again the complete connection of the D.O.L starter internal wiring.
- 15 Get the wiring approved by your instructor.
- 16 Identify the holes in the starter base box for mounting the starter on the wall/frame.
- 17 Mount the starter vertically on the wall/frame.

The position of the starter should be such that the no-volt coil mechanism works properly, taking advantage of the gravitational pull while disengaging.

Use a plumb bob or spirit level to check the verticality.

- 18 Connect the main supply to the starter incoming terminals through the I.C.T.P switch. (Fig 5)

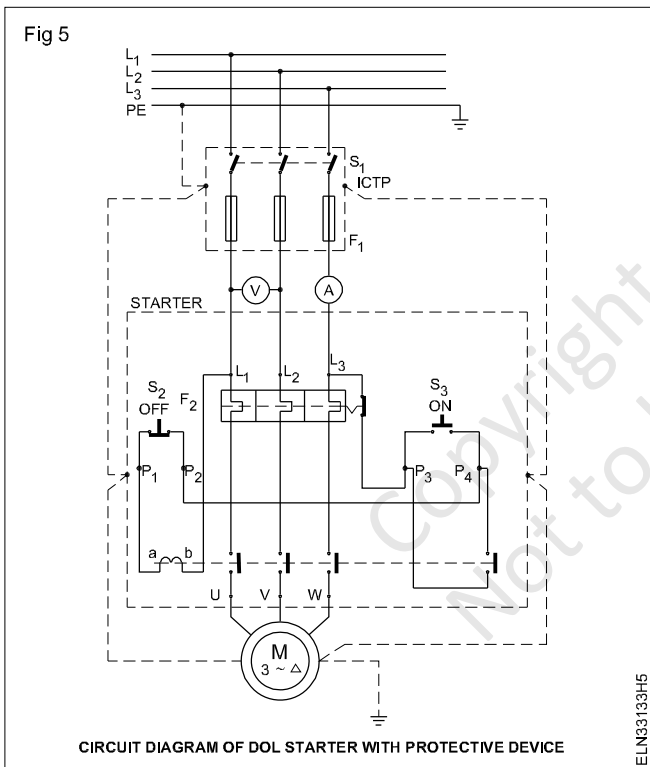

A complete diagram showing the internal diagram of a starter of a particular make along with I.C.T.P switch and motor is given for your guidance. You can replace the internal diagram of the given starter in the place of the starter diagram. (Fig 5)

- 19 Connect the starter outgoing terminals to the 3-phase squirrel cage induction motor along with the ammeter and voltmeter. (Fig 5)

Before connecting the 3-phase squirrel cage motor, test it for continuity and insulation.

- 20 Connect the protective earthing continuity conductors (two separate PE connections) to the motor and starter case, ICTP switch, and connect securely the PE continuity conductors to the main earth. (Fig 5)
- 21 Investigate the full load current of the motor and set the overload relay of the starter to that rating.
- 22 Provide a backup fuse as recommended by the manufacturer of the starter considering the horsepower rating of the motor.

For your guidance the backup fuse rating for a specified horsepower/kw rating.

Preferably check for the backup fuse rating in the pamphlet supplied alongwith your starter.

- 23 Get the main connections, earth connections, overload setting and the backup fuse rating approved by your instructor.
- 24 Switch on the ICTP.
- 25 Start the motor by the start (S_3) button of the starter.
- 26 Read the ammeter for the starting current at the time of starting.
- 27 Read the voltmeter and ammeter values when the motor shows normal runnings.
- 28 Measure the actual speed of the rotor with the help of a tachometer.
- 29 Switch OFF the motor using stop (S_2) button of the starter.
- 30 Switch OFF the mains, remove the fuses and disconnect the connections.
- 31 Determine the synchronous speed and enter the value in Table 3.

Table 3

S No	Starting Current	Volt meter	Running Current	Actual Speed	Syn Speed

- 32 Show the readings to your instructor.

TASK 2 : Start, run and reverse a AC 3 phase squirrel cage induction motor by manual star/delta starter

- 1 Read and interpret the name-plate details of the starter and enter in Table4.

Table4

Starter : Name Plate details

- 2 Switch 'off' the mains, remove the fuse-carriers and keep them in safe custody.
- 3 Remove the terminal cover of the motor and the front cover of the starter.

To connect a star-delta starter, the squirrel cage induction motor must have six terminals, which are normally marked as U_1, V_1, W_1 & U_2, V_2, W_2 .

- 4 Identify the parts of the given star-delta starter, trace the connections and verify its operation. Draw the traced out circuit and get it approved by the instructor.

The layout diagram in Fig 6, the schematic diagram of a star-delta starter in Fig 7 and two types of practical circuits in Figs 8 and 9 are all given for your guidance only.

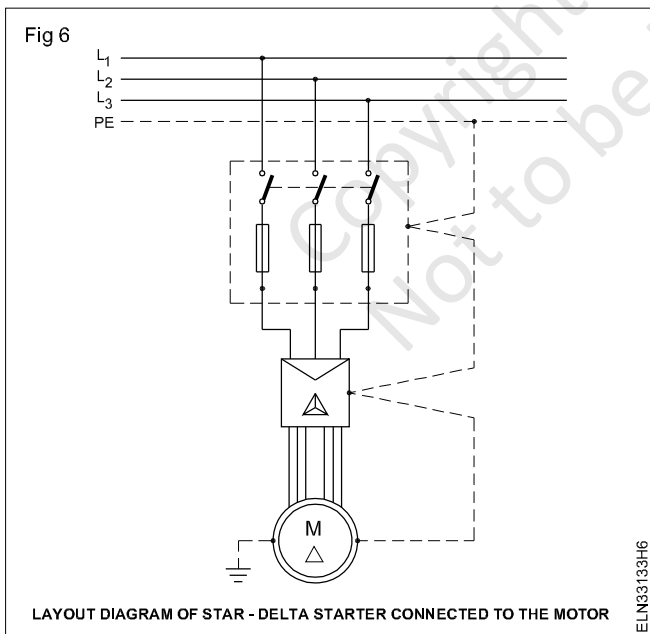

- 5 Draw the complete connection diagram incorporating the ICTP switch, the given star-delta starter and motor and get it approved by your instructor.
- 6 Make the connections of the motor, starter and the ICTP switch as per the approved diagram.
- 7 Connect three cables from supply L_1, L_2 & L_3 to the main switch. (Fig 8 or Fig 9)

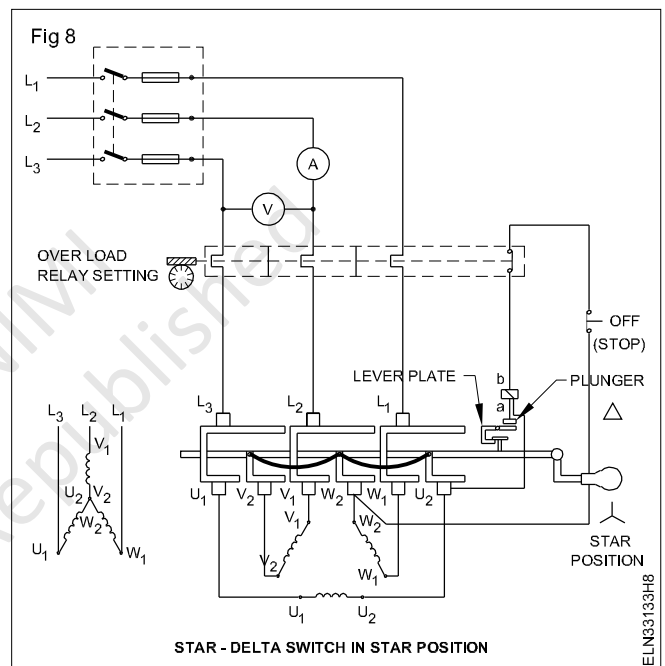
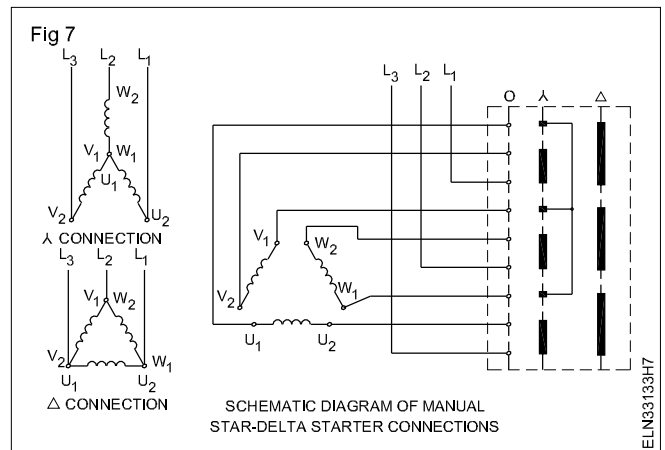

- 8 Insert the ammeter in series with one of the line cables from the main switch and a voltmeter across two line cables. (Fig 8 or Fig 9)
- 9 Wire the proper fuse element according to the given motor rating in the fuse-carrier and insert the carriers in the main switch.
- 10 Set the overload relay according to the full load current rating of the motor.
- 11 Provide double earth to the metal body of the main switch, starter and the motor frame.

ASSUMPTION : Check the connections for correctness and tightness. Get it approved by the instructor.

- 12 Switch 'on' the main, observe the voltmeter reading and move the handle to the star position positively and at the same time observe the starting current and enter it in Table 5.
- 13 Allow the motor to start, race initially and let the sound of the rotating shaft come to a steady state; then move the handle to the delta position positively.

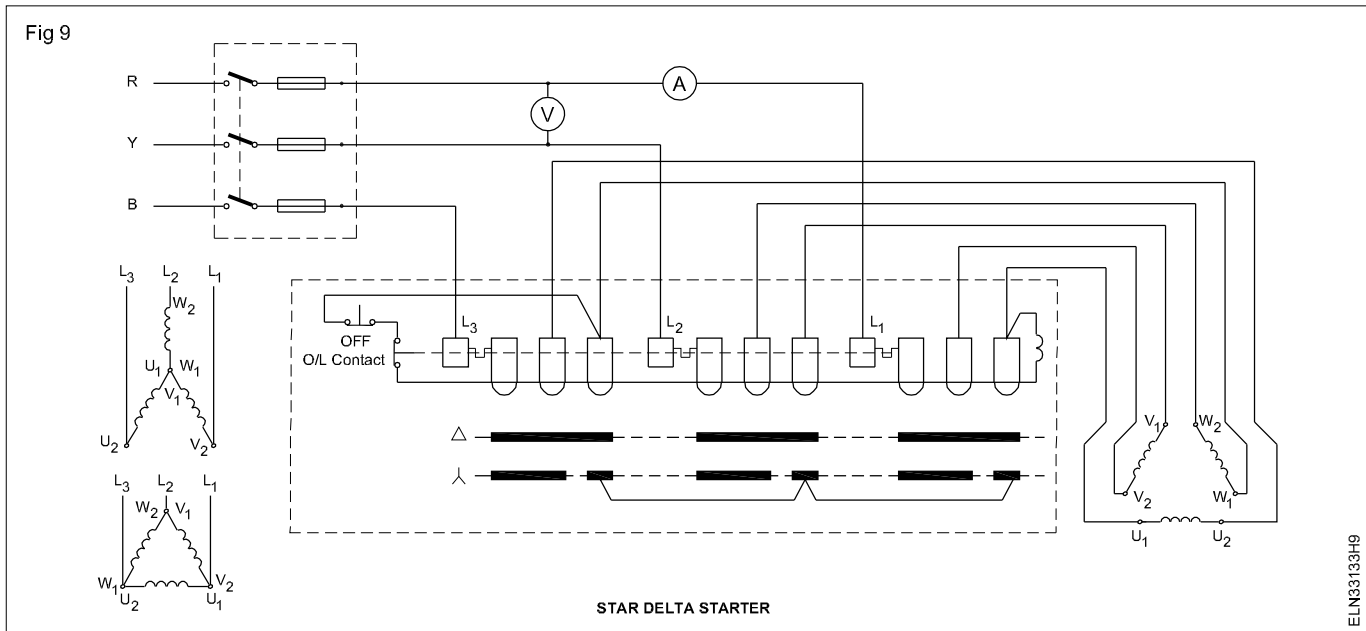

14 Note down the direction of rotation and enter it in Table 5

Table 5

SI. No.	Description	1st Start	2nd Start	3rd Start	Unit
1	Supply voltage				Volts
2	Starting current (Star position)				Amps
3	Running current (Delta position)				Amps

15 Note down the current taken by the motor in running condition and enter the value of the current in Table 6.

Table 6

S.No.	Description	Direction of rotation
1	1st start Connection R to L ₁ Y to L ₂ B to L ₃	
2	2nd start Connection R to L ₂ Y to L ₁ B to L ₃	
3	3rd start Connection R to L ₂ Y to L ₃ B to L ₁	

16 Stop the motor by pressing the stop-button of the starter.

17 Switch 'OFF' the main switch and remove the fuses.

18 Interchange the two line cables R' and Y' to terminals L₂ and L₁ respectively as shown in Fig 10.

19 Insert the fuse-carriers in the main switch.

20 Repeat steps No.12 to 15 and record the information in Tables 5 and 6.

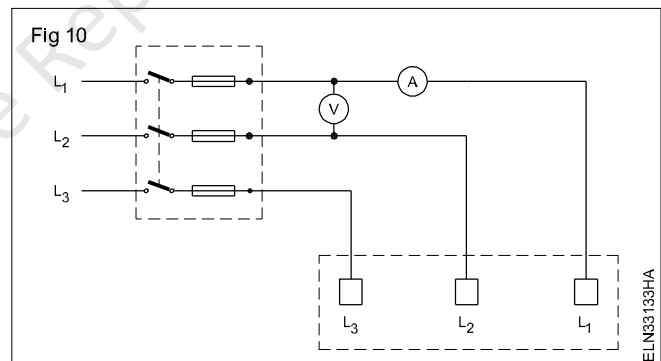

21 Stop the motor, switch off the supply and remove the fuse; then interchange the line cables Y' and B' terminals L₃ and L₁ respectively. (Fig 11)

22 Insert the fuse-carriers in the main switch.

23 Repeat steps Nos.13 to 16 and record the information in Tables 5 and 6.

24 Stop the motor and write your observations about the method of changing the direction of rotation.

25 Switch 'off' the mains, remove the fuse-carriers and remove all connections.

TASK 3 : Connect and run 3-phase induction motor through auto-transformer starter operated by contactors

- 1 Check the insulation and continuity of three-phase induction motor.
- 2 Check the earthing connection for its effectiveness.
- 3 Examine the diagrams. (Fig 11 and 12) What the following symbols in the diagram indicate? Write your response in the space provided).

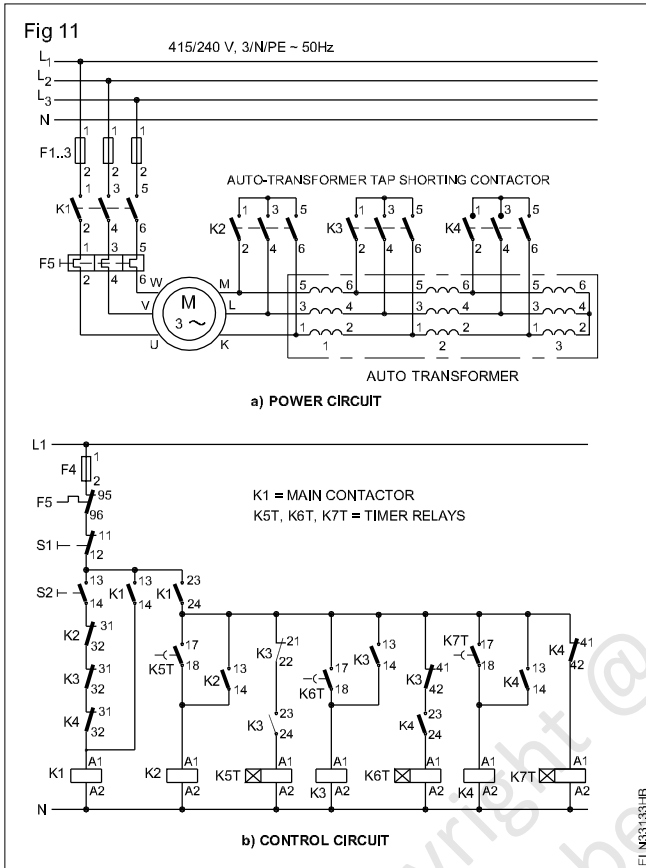

- 4 Draw the power lines connecting the contactors, auto-transformer and motor for sequential operation. (Fig 13)

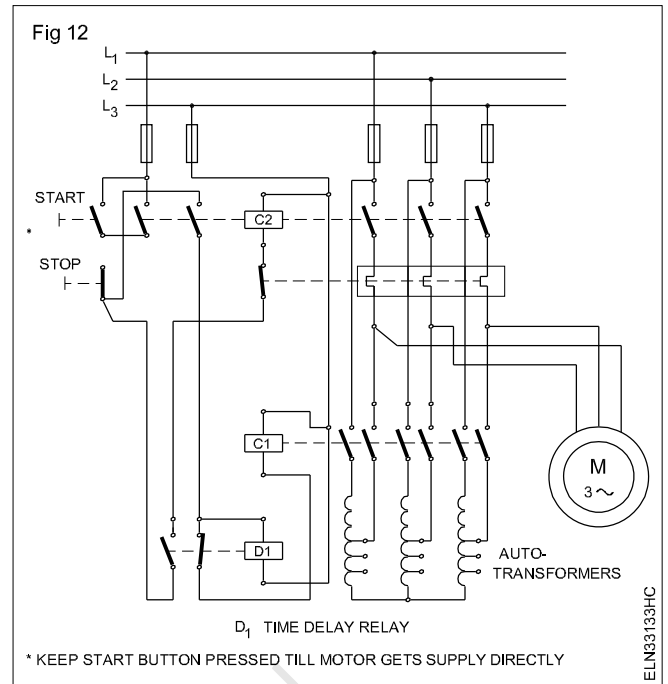

- 5 Mark the different terminals of contactors corresponding to the actual panel provided.
- 6 Draw the control circuit connections including timer and overload trip for sequential operation in Fig 13.
- 7 Complete the connections external to the panel in Fig 13.

Get the circuit checked by the instructor before proceeding.

- 8 Make connections as per diagram.
- 9 Switch on S₁. Switch on the contactor.
- 10 Check when the full voltage to the induction motor is given by the auto-transformer.
- 11 Measure rpm of the induction motor.
- 12 Switch 'OFF' the contactor and then the S₁.

Fig 13

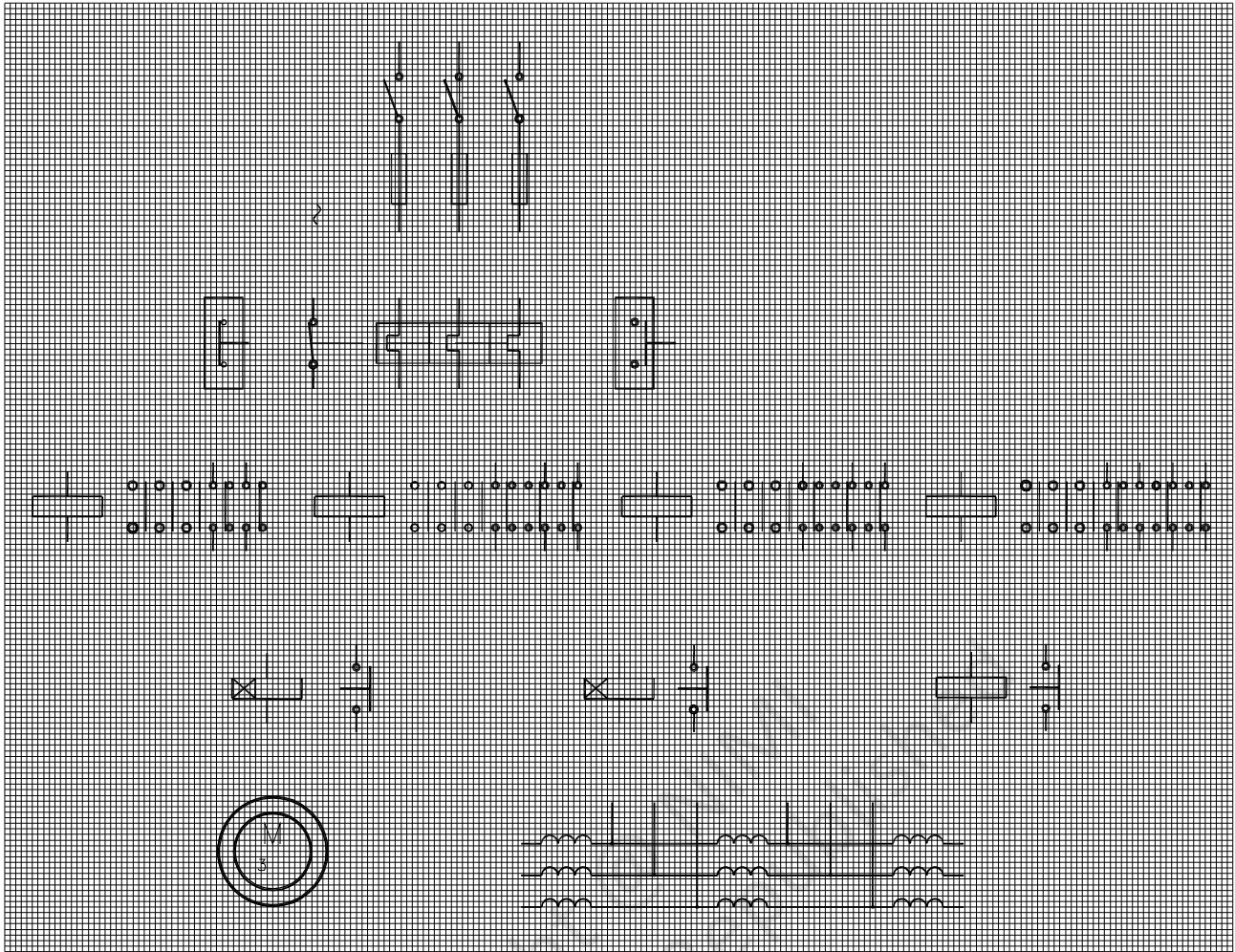

ELN3133HD

Connect, start, run and reverse direction of rotation of slip-ring motor through rotor resistance starter and determine performance characteristic

Objectives: At the end of this exercise you shall be able to

- read and interpret the name-plate details of a 3-phase slip-ring induction motor
- identify the terminals of 3-phase slip-ring induction motor
- identify the parts of a rotor resistance starter, trace the circuit and investigate the operation
- connect the 3-phase, slip-ring induction motor through the rotor resistance starter, start and run the motor
- measure the starting and running current and speed
- reverse the direction of rotation
- load a 3 phase slip ring induction motor and measure the slip.

Requirements			
Tools/Instruments			
• Insulated cutting pliers 200mm	- 1 No.	• Rotor resistance starter, complete set, suitable for 5HP 415V 3-phase slip-ring induction motor	- 1 Set
• Connector screwdriver 100mm	- 1 No.	• Mechanical loading arrangement complete set	- 1 Set
• Electrician's knife 100mm	- 1 No.		
• Screwdriver 200mm	- 1 No.	Materials	
• MI Voltmeter 0-500V	- 1 No.	• PVC insulated, stranded aluminium cable 2.5 sq.mm	- 15 m
• Tachometer 300 r.p.m to 3000 r.p.m	- 1 No.	• PVC insulated, flexible cable 14/0.2mm	- 2 m
• MI Ammeter 0-20A, 0-10A	- 1 each	• Black insulation tape	- 0.2m
• Megger 500V	- 1 No.	• G.I. wire 8 SWG	- 10 m
• MI Ammeter centre zero 5-0-5A	- 1 No.		
Equipment/Machines			
• AC 3-phase, slip-ring induction motor 415V, 5HP, 50Hz	- 1 No.		

PROCEDURE

TASK 1: Connect start, run and reverse the slip-ring induction motor through rotor resistance starter

- 1 Record the name-plate details of the given motor and the starter, and enter them in Tables 1 and 2 respectively.
- 2 Identify the terminals of the 3-phase, slip-ring induction motor.

Slip-ring terminals can be identified by checking the continuity from terminals to the slip-ring.

- 3 Open, identify and trace the internal connections of the rotor resistance starter, draw the diagram and get it approved by the instructor.

Fig 1 gives the layout, Fig 2 gives the power circuit connection diagram, Fig 3 gives the control circuit diagram, and Fig 4 gives the generalised circuit diagram of a rotor resistance starter. Compare it with the traced-out diagram.

- 4 Select the ICTP switch, cables and fuse-wire according to the rotating of the motor.

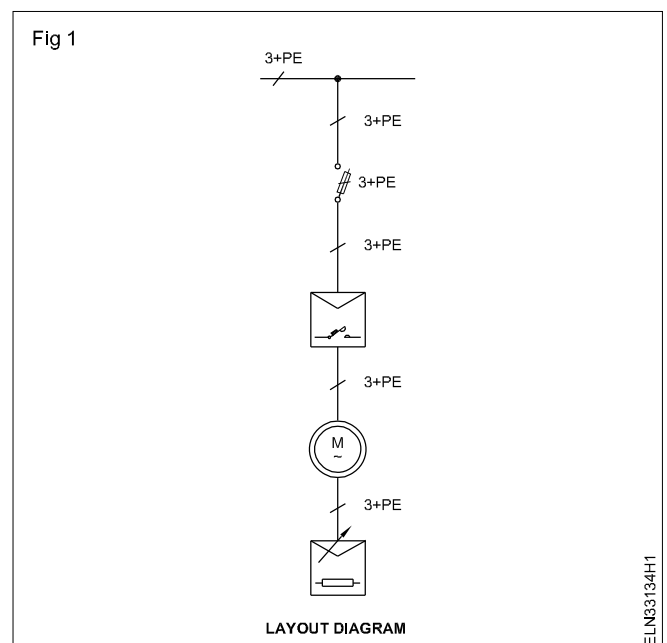

Table 1

Name-plate details of Motor

Manufacturer, Trade Mark	:	Rated frequency	:Hz.....
Type, model	:	Rated power	:Hp.....
Serial number	:	Insulation class	:
Rated current	:	Rated speed	:
Rated voltage	:	Rated current	:

Table 2

Name-plate details of starter

Manufacturer	:	No of Phase	:
Voltage	: Volts	HP/kW	:
Current	: Amp	No.of steps	:
Rotor resistance/phase:	Max. current	:
Serial No.	:	Type of starter	:
Starting current	:		

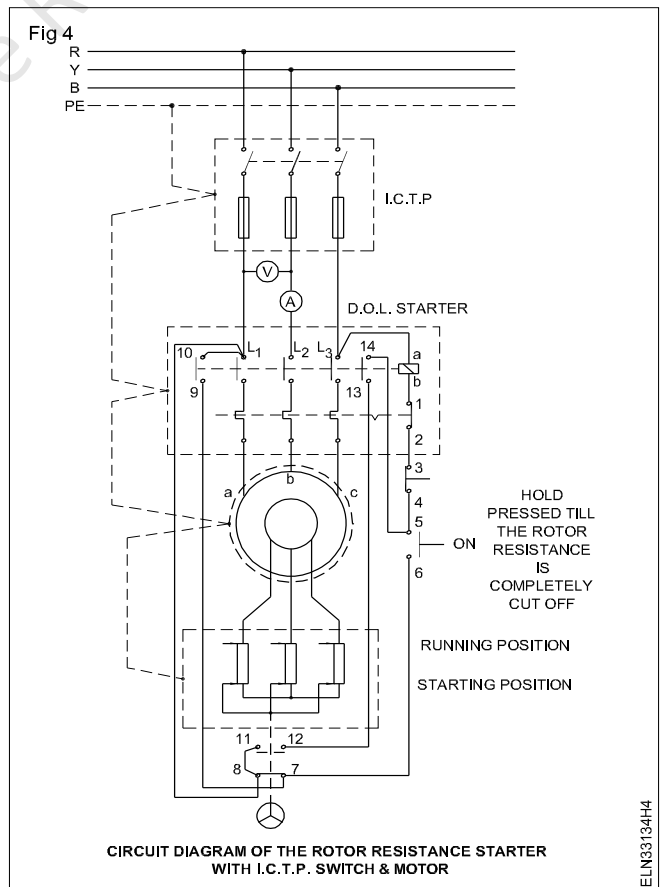
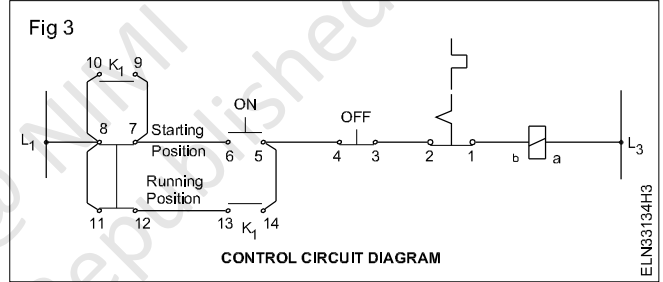
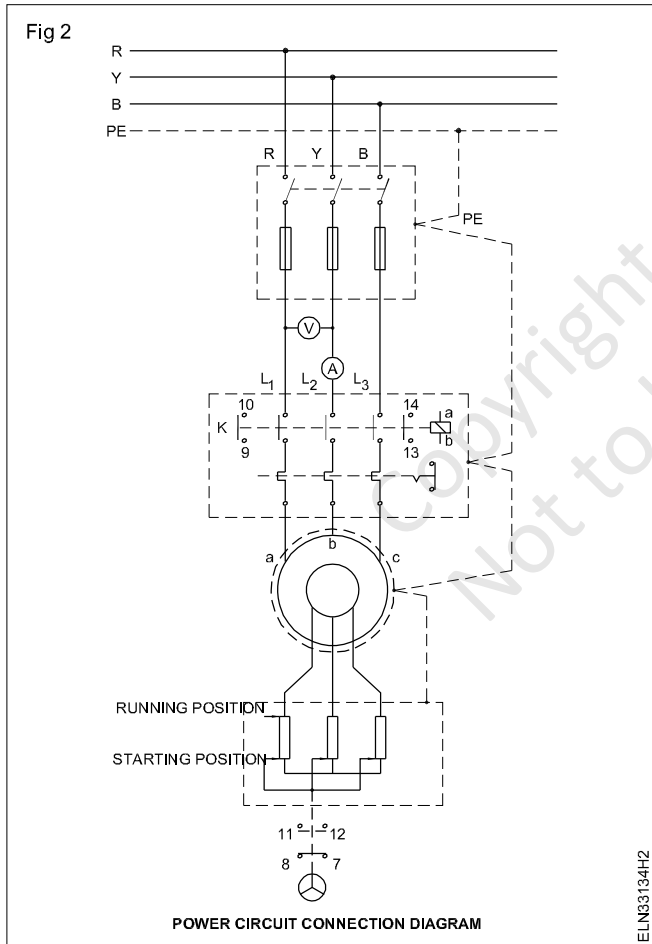

- 4 Select the ICTP switch, cables and fuse-wire according to the rating of the motor.
- 5 Draw the circuit diagram connecting the ICTP, starter, rotor-resistance and the motor, and get it approved by the instructor.

Fig 4 is given to you for your guidance. There may be variations in the practical circuit.

- 6 Connect double earth independently for the main switch starter and the motor. (Use G.I wire No.8 SWG as earth wire)
- 7 Connect the motor, starter, main switch meters as per the approved diagram (Fig 4) and get it checked by the instructor.
- 8 Check the supply and provide proper rating fuses in the main switch according to the motor rating.

To start and run the motor

- 9 Keep the rotor resistance starter handle in the starting position (cut in) of the rotor resistance.

'Cut in' position of the rotor resistance is generally indicated in the starter as 'starting position' or 'off position'.

- 10 Press the start-push button of the starter. While pressing the start-push button, slowly move the handle of the rotor resistance from the starting position towards the running position till it settles down at 'run' position.

- 11 Note down the reading of the voltmeter, ammeter at the time of just starting and normal running positions. Record them in Table 3.
- 12 Release the pressure from the start-push button.
- 13 Note down the direction of rotation. The direction of rotation is
- 14 Measure the speed and enter in Table 3.
- 15 Press the 'OFF' button of the starter to stop the motor.
- 16 Do not start the motor when the rotor-resistance handle is in the running position. The motor starts only when the rotor-resistance handle is in the starting position. (Fig 4) The motor will not start in any intermediate position or in the running position.

Investigate the following:

- Whether the motor could be started when the rotor resistance handle is at the running position.
- Whether the motor could be started when the rotor resistance handle is at an intermediate position between the starting and running positions.

Table 3

(L-with air gap)

Measured resistance = ...ohms

Sl. No	Line voltage in volts	Starting current in amp	Running current in amp	Full load current as shown in the name plate in amps	Speed rpm

- Whether the motor could be started when the rotor resistance handle is at the starting position.

Write your conclusion.

- 17 Switch OFF the ICTP switch and make sure the supply is disconnected, and the fuses are removed and kept in safe custody.
- 18 Interchange any two of the line wires, either in the starter terminal (Fig 5a) or in the motor terminals. (Fig 5b)

Change either the outgoing cable of switch ICTP or the incoming cables of the starter, whichever is easier.

- 19 Replace the fuses, switch 'ON' the mains and run the motor, observe and record the direction of rotation. The direction of rotation is

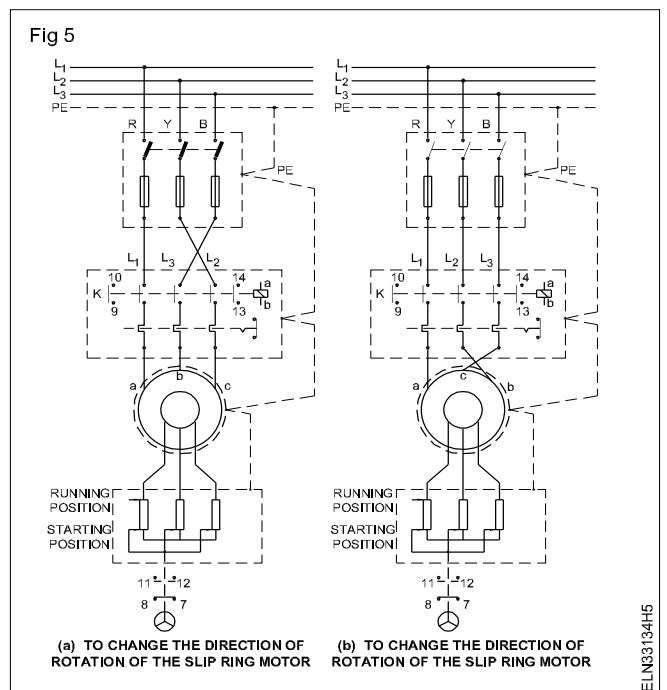

20 Stop the motor, switch 'off' the mains, remove the fuses and disconnect the cables.

TASK 2 : Determine the performance characteristics of a slip ring induction motor

- 1 Make the connections as per diagrams (Figs 6 & 7).
- 2 Check and ensure the control circuit wiring of the starter panel is same as Fig 7.

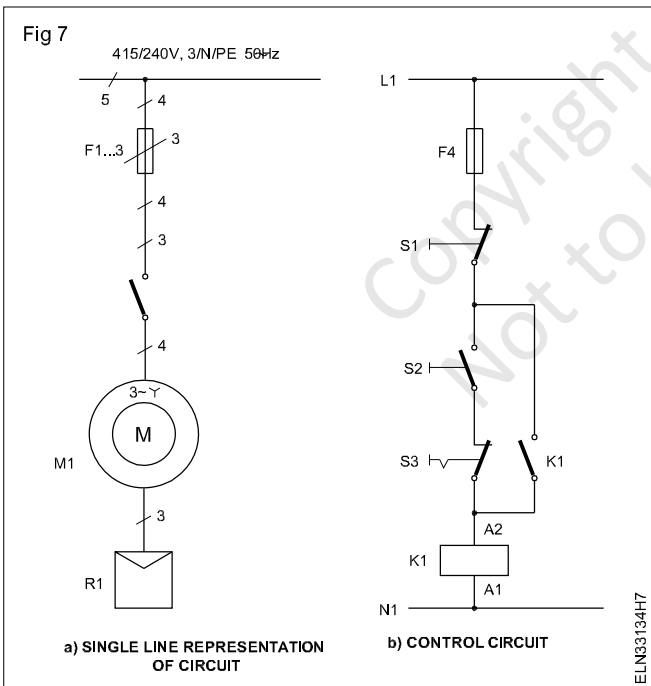
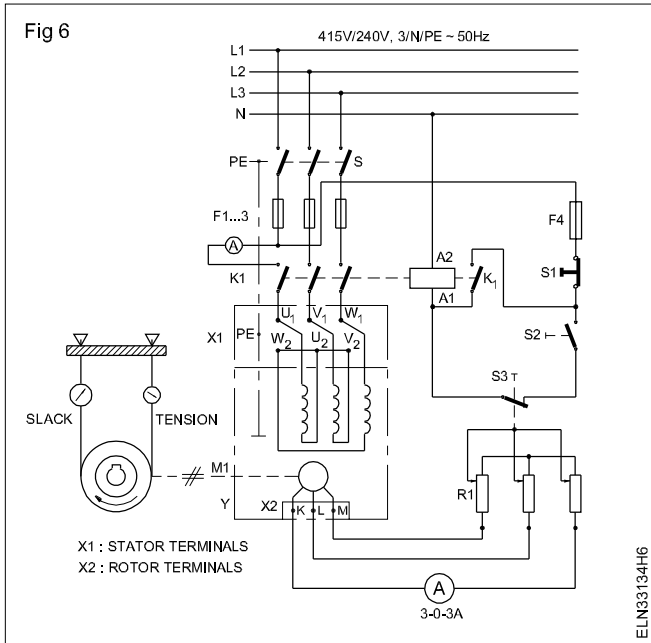

Use the diagram shown in Fig 8 if the motor starter is drum type one.

3 Check the supply voltage for the rated value and switch on the ICTP switch.

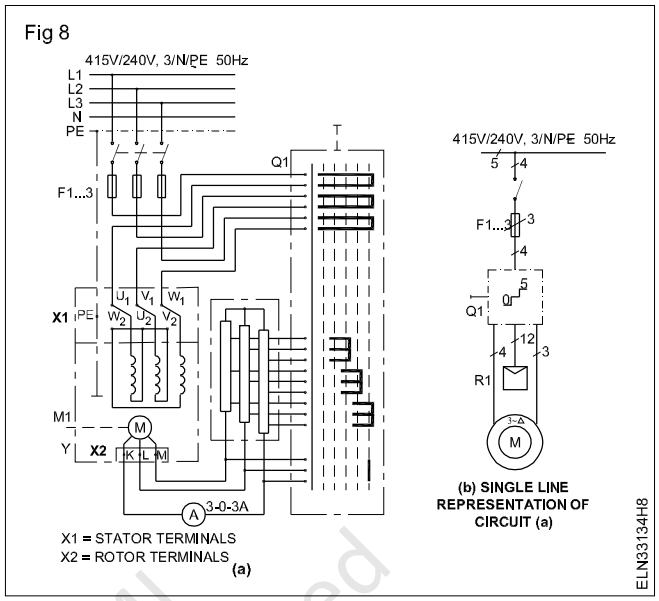

4 Start the motor on no-load.

Make sure the rotor resistance starter handle is in the starting position. Otherwise the motor will not start.

- 5 Cut down the rotor's circuit resistance to zero gradually observing the increasing speed of the motor.
- 6 Watch the deflections of the ammeter pointer in the rotor circuit and note that it oscillates on either side.
- 7 Start the stop watch and measure the oscillations of the ammeter pointer for one minute and record in Table 4.
- 8 Load the motor with a brake load to about 25%, 50%, 75% & 100% and record the number of oscillations of the ammeter per minute in each case. (Table 4)

The load on motor is determined by the current taken by it from supply.

9 Determine the rotor current frequency at standstill is equal to the supply frequency to the stator.

Rotor current frequency (f_r) while running is supply frequency f_s $f_r = s \times f$

10 Apply the formula

$$\text{Slip} = \frac{\text{rotor frequency } f_r}{\text{supply (stator) frequency } f}$$

Table 4

Load current in Ampere	Ammeter Oscillation	Oscillation per second	Slip ($S = f_r/f$)
No load			
About 1/4 FL			
About 1/2 FL			
About 3/4 FL			
Full load			

Copyright @ NIMI
Not to be Republished

Determine the efficiency of squirrel cage induction motor by brake test

Objectives: At the end of this exercise you shall be able to

- select suitable instruments from the name-plate details of the motor
- connect and conduct the test for actual loading with brake
- calculate the output from the readings of the spring balance
- calculate the efficiency of the motor
- draw the graph of load versus efficiency.

Requirements	
Tools/Instruments <ul style="list-style-type: none"> • Tachometer: multi-range 300 to 3000 r.p.m - 1 No. • MI Voltmeter (0 - 500V) - 1 No. • MI Ammeter (0 - 10A) - 1 No. • Wattmeter dynamometer type 500V, 10A, 3000W - 2 Nos. • Spring balance 10 kg - 1 No 	Equipment/Machines <ul style="list-style-type: none"> • 3-phase squirrel cage induction motor 415V, 3 HP 50Hz - 1 No. • Brake loading arrangement DOL starter 415V AC 3-phase, 50Hz, 10A - 1 No. • Connecting cables - as reqd. • ICTP switch 16A, 415V - 1 No. • Graph sheet (A4 Size) - 1 No.

PROCEDURE

- 1 Note the name-plate details of the squirrel cage induction motor in Table 1.
- 2 Select the voltmeter, ammeter and wattmeter range suitable to the specification given in name-plate details. Make connection as per circuit diagram. (Fig 1)
- 3 Fix the brake drum's rope or belt with the spring balances in slack condition.
- 4 Switch 'ON' ICTP switch 'S' and start the motor at no-load.
- 5 Measure the speed and record in Table 2.
- 6 Tighten the belt to apply brake action on the brake drum, until the motor takes 1/4 full load current.

Check the mounting of the motor to the base is firm. Check the brake drum is properly keyed to the shaft.

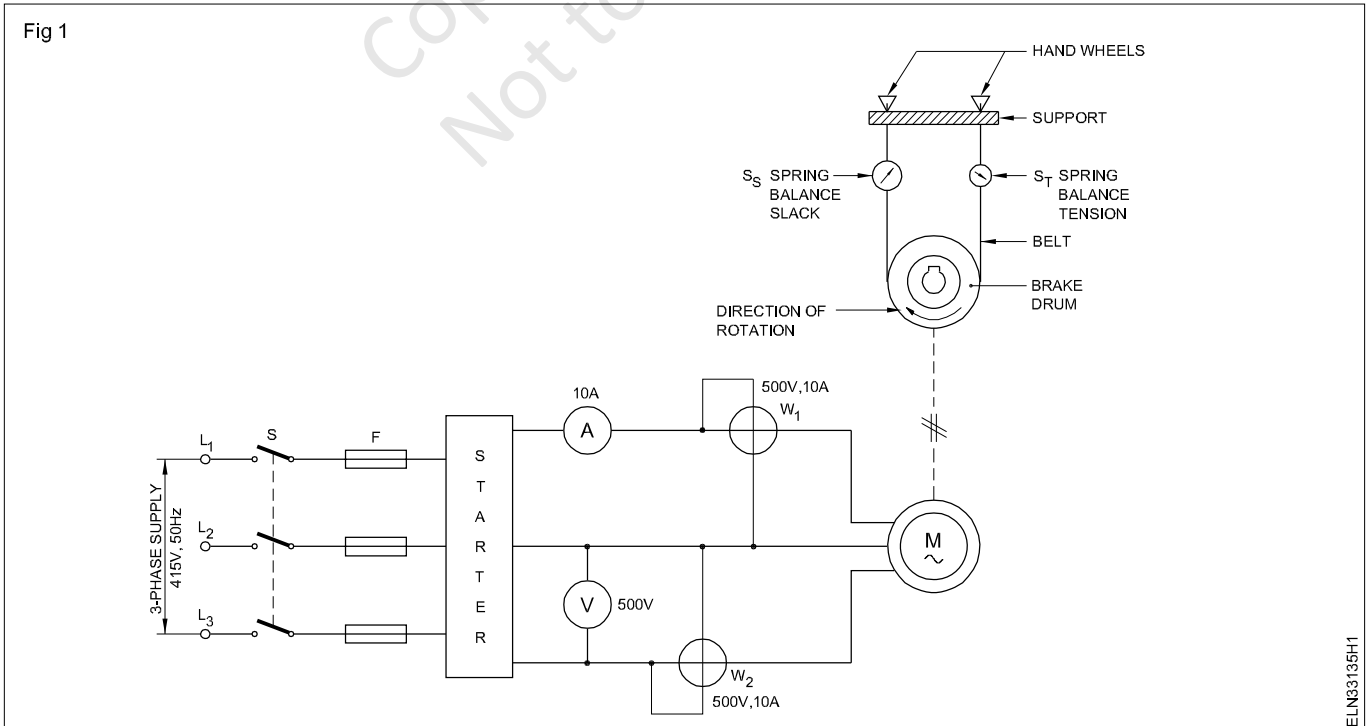

Apply and regulate the required amount of cooling water to the brake drum.

- 7 Read the spring balances (Tension side S_T , slack side S_S) and record in Table 2.
- 8 Record the voltmeter, ammeter and wattmeter readings in Table 2.
- 9 Measure the speed of the motor at this loaded condition and record in Table 2.
- 10 Repeat the steps 6 to 9 for different load currents, say about 1/4, 1/2, 3/4 and full load.
- 11 Measure the diameter of the brake drum and the thickness of the rope/belt.
- 12 Drum radius 'R' = _____ m.
Rope/belt thickness 't' _____ m
- 13 Calculate the torque

Torque, $T = (S_T - S_S) \times (R + t)$ Kg m

where $(R + t)$ is in metre, $(S_T - S_S)$ is in Kg.

Record the torque and output in Table 3.

- 14 Calculate the output applying the formula,

Output = $1.027 NT$ watt

where N - revolutions per minute, T - torque in Kg m

- 15 Calculate the motor input and record in Table 3.

Input = $(W_1 + W_2)$ watt

- 16 Calculate the efficiency of the motor and record.

(Efficiency = Output/Input)

- 17 Plot the graph for the relationship - load in KW versus efficiency in %.

Conclusion

Efficiency of induction motor.

Table 1

Manufacturer's name :	_____		
Voltage :	_____	Phase :	_____
Current :	_____	Speed :	_____
Power factor :	_____	KW/HP :	_____
Connection :	_____	Rating :	_____
Starting current :	_____	Serial No. :	_____

Table 2

S No.	Speed in rpm	Reading of spring balance tension		Volt meter reading	Ammeter reading	Wattmeter reading
		S_T	S_S			

Table 3

S No.	Speed	Torque T	Output	Input ($W_1 + W_2$)	Efficiency
1					
2					
3					
4					
5					

Determine the efficiency of 3 phase squirrel cage induction motor by no-load test and blocked rotor test

Objectives: At the end of this exercise you shall be able to

- conduct a no-load test for a given 3-phase squirrel cage induction motor
- conduct blocked rotor test for the above 3-phase squirrel cage induction motor
- determine the constant losses and copper loss at full load.

Requirements	
<p>Tools/Instruments</p> <ul style="list-style-type: none"> • MC Voltmeter (0-30V) - 1 No. • MI Ammeter 0-2.5A - 1 No. • MI Ammeter 0-2A - 1 No. • MI Ammeter 0-10A - 1 No. • Wattmeter 500V, 1A/2.5A low power factor - 2 Nos. • Wattmeter 125/250V, 10/15A multi range - 2 Nos. • Voltmeter MI 0-500V - 1 No. • Voltmeter MI 0-75, 150, 300V multi range - 1 No. 	<p>Equipment/Machines</p> <ul style="list-style-type: none"> • 3-phase induction motor 500V, AC, 50Hz, 3 HP - 1 No. • DOL starter 500V, AC, 50Hz, 3 HP - 1 No. • 3-phase auto-transformer input 415V, output 0-500V 3 KVA - 1 No. • Lock bar/locking arrangement - 1 No. <p>Materials</p> <ul style="list-style-type: none"> • Connecting cables - as reqd. • ICTP switch 16A, 500V - 1 No.

PROCEDURE

TASK 1 : Conduct No-load test

- 1 Record the name-plate details of the induction motor in Table 1.

Table 1

Manufacturer's Name :		Phase :	
Voltage :		Speed :	
Current :		KW/HP :	
Power factor :		Rating :	
Connection :			

- 2 Collect the instruments to form the circuit. (Fig 1)
- 3 Make the connections as per circuit diagram. (Fig 1)

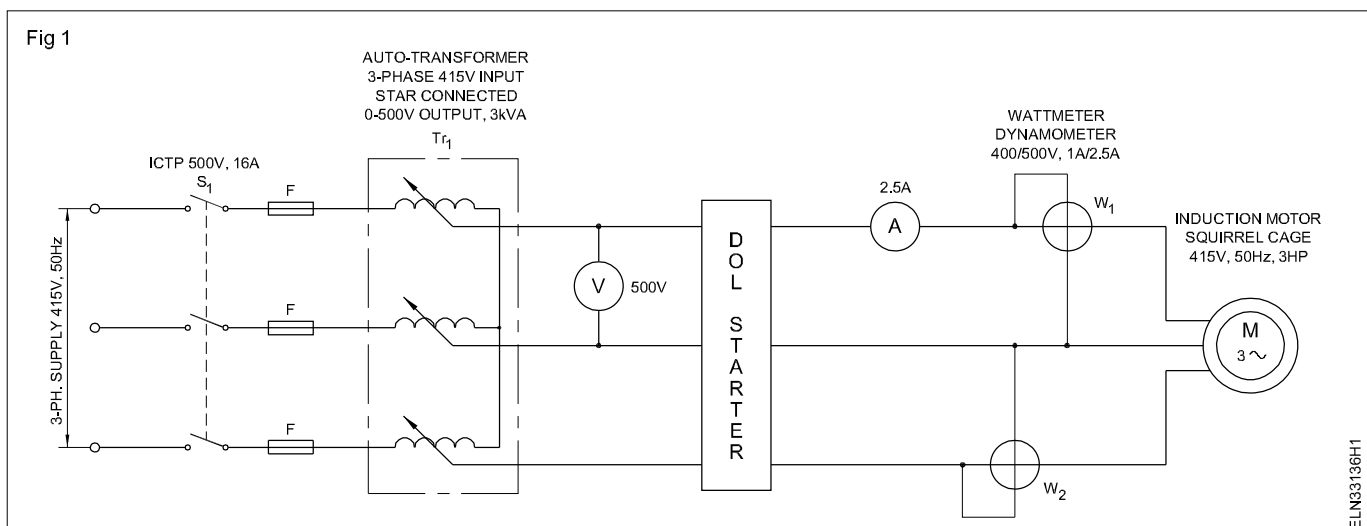

- 4 Check the supply for the rated value and switch 'ON' the ICTP switch (S_1) (If the value is not correct adjust by auto transformer)
- 5 Start the motor without any load.
- 6 Read and record the wattmeter, ammeter and voltmeter readings in Table 2.
- 7 Switch 'OFF' the supply and disconnect all connections of the meters, and the motor.

Table 2

Input voltage	Power input $W_o = (W_1 + W_2)$	No-load current I_o

- 8 Check the connections of the 3-phase supply leads to the motor terminals. If six terminals are available identify each phase winding.
- 9 Measure the resistance of the stator using DC low voltage supply, ammeter and voltmeter. Record the reading in Table 3.

Table 3

DC supply voltage	Ammeter reading	Resistance of stator (one phase)

- 10 If the motor has only 3 terminals, and the internal connections are marked on the name plate, make calculations as below.

For star connection

$$\text{Resistance per phase } R_p = \frac{V}{I} \times \frac{1}{2}$$

$$\text{Therefore } R_p = \frac{R}{2}$$

For Delta connection

$$\text{Resistance between two terminals } R = \frac{V}{I}$$

Let the resistance per phase = R_p

$$R = R_p \parallel 2R_p \text{ (} R_p \text{ parallel to } 2R_p \text{)}$$

$$\text{i.e. } \frac{1}{R} = \frac{1}{2R_p} + \frac{1}{R_p}$$

$$\text{Resistance measured} = \frac{2}{3}R_p$$

Therefore R_p (resistance per phase of stator) is = $\frac{2}{3}R$

Calculations

The no-load input: $W_o =$ No load copper loss

$$= (I_{oph}^2 R_p) \times 3$$

(I_{oph} = no load phase current)

For star connected motor $I_o = I_{oph}$

For delta connected motor $I_{oph}^2 = \frac{I_o^2}{3}$

The losses at no load are

- $I^2 R$ loss in the stator winding
- Core losses in the stator and rotor
- friction and windage losses

Core losses and friction and windage losses practically remains constant in induction motor

$$\text{Constant losses} = W_o - (I_{oph})^2 R \cdot 3$$

TASK 2 : Conduct blocked rotor test

- 1 Collect the instruments to form circuit as per diagram. (Fig 2)
- 2 Make the connections as per circuit diagram. (Fig 2)

Keep the auto-transformer at zero output voltage position.

- 3 Switch on ICTP switch ' S_2 '.
- 4 Increase the output of the auto-transformer voltage gradually, watching the ammeter, till the current is equal to full load current.

- 5 Read and record the wattmeter, voltmeter and ammeter readings in Table 4.

Table 4

Input voltage V	Power input W	Blocked current I

Calculation

Wattmeter reading = full load $I^2 R$ loss.

$$= 3I^2 R_e,$$

Fig 2

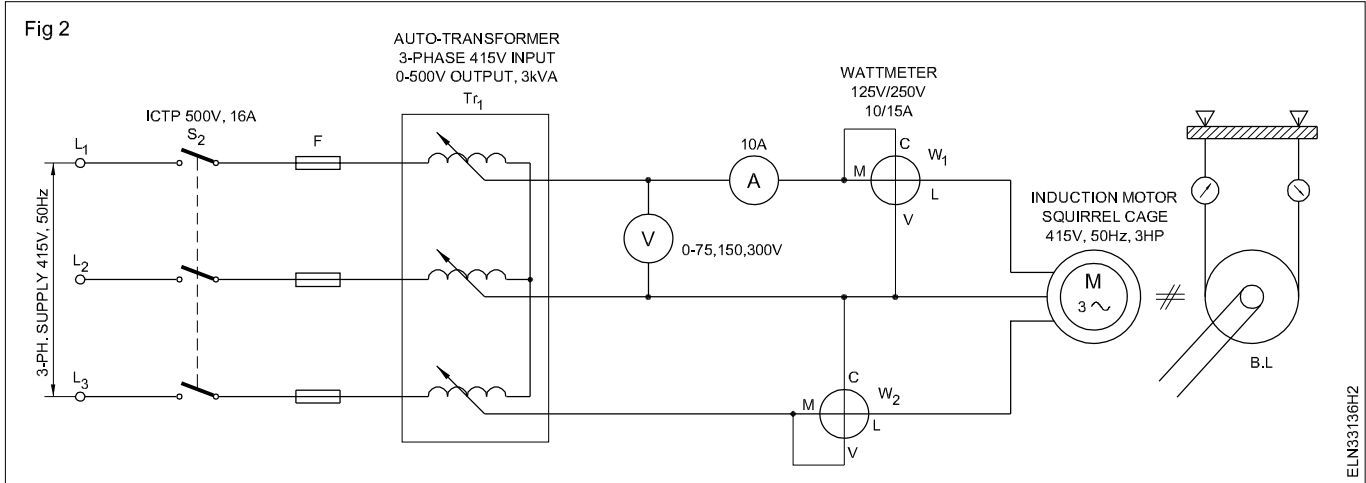

where R_e = Resistance of stator winding per phase

$$\text{Wattmeter reading} = 3I_p^2 R_e,$$

$$I^2 R \text{ at no load} = 3I_0^2 R_e$$

Magnetic losses = No load input – copper loss.

Total loss = full load $I^2 R$ loss + Magnetic losses

= Block rotor wattmeter reading + Magnetic losses

$$\text{Efficiency} = \frac{\text{Output}}{\text{Input}} = \frac{\text{Input} - \text{Losses}}{\text{Output} + \text{Losses}}$$

Determine the efficiency of the motor at full load.

Constant losses

$$= \text{Copper loss at full load} = 3I_p^2 R_e \text{ watts}$$

where R_e – equivalent resistance/phase

I_p – full load current/phase

Copper loss at full load = _____ watts.

Input

$$= \sqrt{3} \times v \times I \times \text{pf} = \text{_____ watt.}$$

Total losses = constant losses + copper loss

Therefore, efficiency = _____

6 Determine the efficiency when the input current is 0.7 full load and p.f is 0.8.

Conclusion

Measure slip and power factor to draw speed torque (slip/ torque) characteristics

Objectives: At the end of this exercise you shall be able to

- identify the terminals of a slip ring induction motor
- wire up and connect resistance starter
- start, run the slip ring induction motor
- plot the graph of speed torque characterisitc of slip ring induction motor.

Requirements

Tools/Instruments

- MI Ammeter 5/10A multirange - 1 No.
- MI Voltmeter 250/500V multirange - 1 No.
- Tachometer multi-range 300, 1000, 3000 rpm - 1 No.

Equipment/Machines

- 3-phase auto-transformer input 415V star connected, output 0-500V, 3kVA - 1 No.

- 3-phase slip ring induction motor, 3HP, 415V, 50 Hz with rotor resistance starter - 1 No.

Materials

- ICTP switch 16A 415V - 2 Nos.
- Connecting cables - as reqd.
- Graph sheet (A4 Size) - 1 No.

PROCEDURE

- 1 Read the name-plate details of slip ring induction motor and record in Table 1.
Select the instruments of suitable range to form the circuit as per diagram. (Fig 1)
- 2 Make the connections as per circuit diagram (Fig 1) and Set the output of three-phase auto-transformer to minimum.
- 3 Switch on ICTP 'S₁' and adjust the output of the 3-phase variac to 40% of the rated input voltage of the motor.

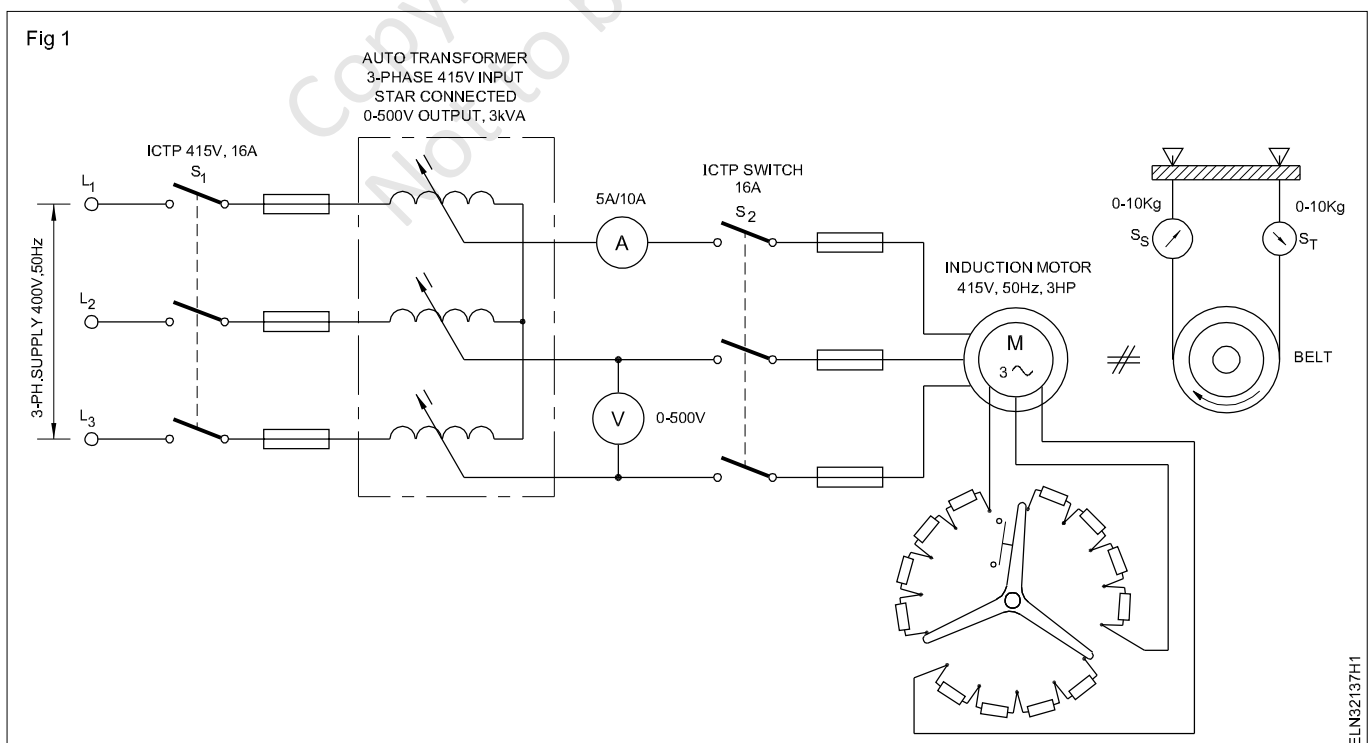

Table 1

Manufacturers's name :	Phase :
Voltage :	Speed :
Current :	KW/HP :
Power factor :	Rating :
Connection :	Serial No :
Rotor resistance/Phase:	

- 4 Check the load on the brake drum which is totally removed.
- 5 Set the rotor resistance starter not to include any resistance in the rotor circuit (i.e rotor terminals are shorted by the starter).
- 6 Close the switch S_2 and start the motor.
- 7 Measure the speed, current and record in Table 2

Table 2

	Stator input voltage	Stator current	Speed	Slip	S_T	S_s	Motor output torque
Without extra resistance in rotor circuit							
With additional resistance in rotor circuit							
-do-							
-do-							

- 8 Load the motor by adjusting the spring tension of the belt on the brake drum/pulley until the speed falls to a very low value.
- 9 Check the speed, stator current, voltage for each setting of a load and record in Table 2.
- 10 Remove the load on the motor and allow it to run in no load condition.
- 11 Increase the resistance in the rotor circuit by adjusting the rotor starter handle in two or three steps and repeat steps 7 to 10.
- 12 Apply the formula and calculate the torque.
- 13 Record the calculated value of torque and slip in Table 2.
- 14 Plot the graph of speed/slip - torque for each rotor resistance.

S_s - spring balance reading and slack side of belt in kg
 R - radius of Drum/pulley in metre
 t - thickness of belt in millimetre

Conclusion

Torque (T) = $(S_T - S_s) (R + t)$

where

S_T - spring balance reading on tension side in kg

Test for continuity and insulation resistance of three phase induction motors

Objectives: At the end of this exercise you shall be able to

- read and interpret the name-plate details of a 3-phase squirrel cage induction motor
- identify the terminals of the 3-phase induction motor
- perform insulation resistance test between phase windings
- perform insulation resistance test between winding and body
- test the effectiveness of earth connection.

Requirements			
Tools/Instruments			
• D.E spanner 5mm to 20m	- 1 Set	• M.I voltmeter 0-50V	- 1 No.
• Cutting pliers 150mm	- 1 No.	• M.I voltmeter 0-25A	- 1 No.
• Screwdriver 200mm	- 1 No.	Equipment/Machines	
• Megger 500V	- 1 No.	• AC 3-phase, 415V / 3 H.P.	- 1 No.
• Ohmmeter low range 0-10 Ohm	- 1 No.	squirrel cage induction motor	
• Test lamp 240V, 60W	- 1 No.	Materials	
• Earth tester with spikes and connecting lead	- 1 Set	• Connecting cables 2.5 mm ² of length 40m	- 1 No.
• Hammer straight peen 1.5kg	- 1 No.	• Connecting cables 2.5 mm ² of length 10m	- 1 No.
• M.C voltmeter 0-10V	- 1 No.	• Testing prods	- 1 Pair
• M.C ammeter 0-20A	- 1 No.		
• Calibrated rheostat 0.1 ohm, 10 amp	- 1 No.		
• Battery 6V, 60 A	- 1 No.		

PROCEDURE

TASK 1 : Test the continuity of 3 phase induction motor

- 1 Note the name-plate details of the induction motor and enter them in Table 1.
- 2 Identify the terminals of the given AC induction motor from the markings.
- 3 Connect the test loads of the megger to the terminals U₁ and U₂. (Fig 1)
- 4 Rotate the megger at its rated speed and note down the readings in Table 2.
- 5 Repeat the steps 3 and 4 by connecting the megger terminals between V₁ and V₂ and also between W₁ and W₂. Record the finding in Table 2.

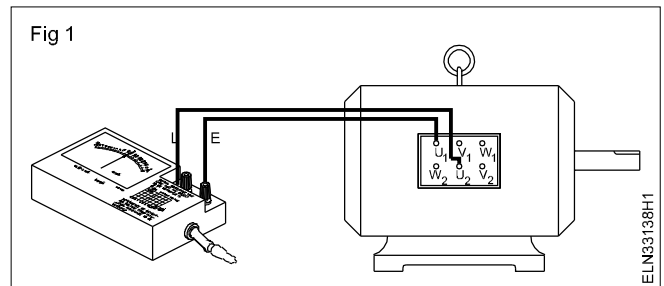

The megger reading should be zero, if the winding of the motor is having continuity.

The megger reading should be high or infinity (∞) if the winding of the motor is open.

Table 1

Manufacturer, Trade Mark :.....	Rated frequency:.....Hz.....
Type, model number :.....	Rated power :KW/HP
Type of Current :	Rating class :
Serial number :	Insulation class:
Type of connection :.....	Rated current :amps
Rated voltage :Volts...	Rated speed: r.p.m
	Protection class :

Table 2

Continuity test for 3 phase induction motor

Sl.No	Between terminals	Meter reading	Remarks
1	U ₁ and U ₂		
2	V ₁ and V ₂		
3	W ₁ and W ₂		

TASK 2: Measure the insulation resistance value between the windings

- 1 Connect the test leads of the megger to the terminals U₁ and V₁. (Fig 2)
- 2 Rotate the Megger at its rated speed and note down the readings in Table 3.

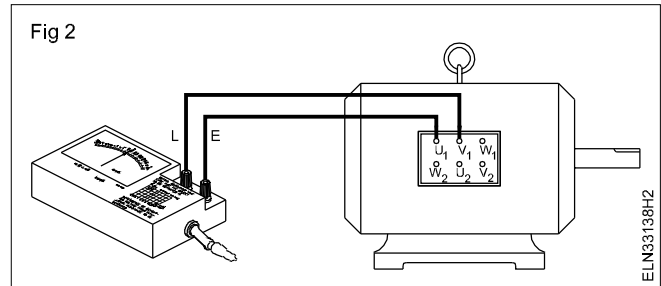

Table 3

Insulation resistance of 3-phase induction motor

Sl. No	Between terminals	Insulation resistance	Remarks
1	U ₁ and V ₁		
2	U ₁ and W ₁		
3	V ₁ and W ₁		
4	U ₁ and frame		
5	V ₁ and frame		
6	W ₁ and frame		

- 3 Repeat the steps 1 and 2 by connecting the Megger terminals between U₁ and W₁, and also between V₁ and W₁. Record the findings in Table 3.

Recommended standard insulation resistance

$$R_1 = \frac{20 \times E_n}{1000 + 2P} \text{ in megohm .}$$

where

R₁ = insulation resistance in megohms at 25°C.

E_n = rated phase-to-phase voltage

P = Rated power in kW.

If the resistance is measured at a temperature different from 25°C, the value shall be corrected to 25°C.

The equation given here is used to calculate the insulation resistance as a standard value. However the accepted insulation value should not be less than 1 megaohms.

TASK 3 : Measure the insulation resistance between each winding and body or frame

- 1 Connect the test leads of the Megger to the frame of the motor and terminal U₁. (Fig 3)

The Megger connection to the frame should be done at the earthing stud of the frame. Before connecting, remove the varnish, dust, dirt and grit thoroughly at the earthing stud.

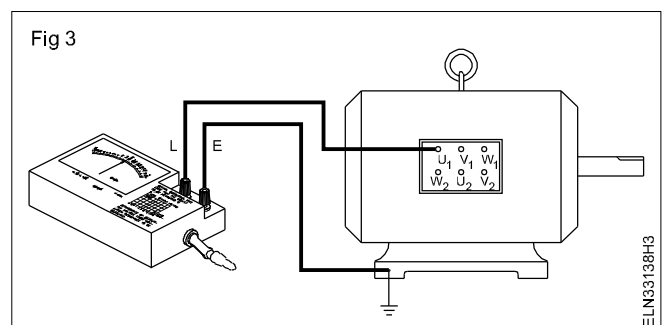

- 2 Rotate the Megger at its rated speed and note down the readings in Table 4.
- 3 Repeat steps 1 and 2 for the other two windings (V_1 and W_1).
- 4 Compare the measured value with the standard value.

TASK 4 : Measure the resistance of the earth continuity conductor (E.C.C)

- 1 Measure the resistance of the earth continuity conductor (ECC) and enter the value in Table 4.
- 2 Measure the earth electrode resistance and enter the value in Table 4.
- 3 Write the conclusion in the remarks column of table indicating whether the fuse will blow in case of earth fault in the above circuit, or suggest methods to be adopted to have effective earth connection in the above case.
- 4 Write below your suggestion to have effective earth connection to isolate the circuit under earth fault by fuse or circuit breaker.

Table 4

Insulation resistance of 3-phase induction motor

SI No.	Resistance E.C.C. R_{ECC}	Resistance earth electrode R_{EE}	Total earth resistance $R_e = R_{ECC} + R_{EE}$	Voltage between phase and earth E_p	Earth fault current $I_F = \frac{E_p}{R_E}$	Fuse rating of the motor Circuits	Remarks
1	U_1 and V_1						
2	U_1 and W_1						
3	V_1 and W_1						
4	U_1 and frame						
5	V_1 and frame						
6	W_1 and frame						

Perform speed control of 3-phase induction motors by various methods like rheostatic control, auto transformer etc.

Objectives: At the end of this exercise you shall be able to

- connect the 3 phase slipping induction motor through rotor resistance starter
- control the speed of a 3-phase slipping motor by rotor resistance starter
- connect a 3 phase induction motor to an auto transformer starter
- control the speed of a 3 phase induction motor by auto transformer starter.

Requirements	
Tools/Instruments	
<ul style="list-style-type: none"> • Insulated cutting pliers 200mm - 1 No. • Cconnector screw driver 100 mm - 1 No. • Electrician's knife 100 mm - 1 No. • Screw driver 200mm - 1 No. • MI Voltmeter - 0-500 V - 1 No. • Tachometer 300 rpm to 3000 rpm - 1 No. • Megger 500V - 1 No. 	<ul style="list-style-type: none"> • Rotor resistance starter complete set suitable for 3HP - 1 No. • AC 3 phase squirrel cage induction motor 500V, 5 HP - 1 No. • Auto - transformer starter complete set suitable for 5 HP - 1 No.
Equipment/Machines	
<ul style="list-style-type: none"> • AC 3 Phase slipping induction motor 415V/3HP - 1 No. 	<ul style="list-style-type: none"> • PVC Insulated flexible cable 2.5 sqmm - 20 m • IC TP switch 10A 500V - 2 Nos. • Test Lamp 40 W 250V - 1 No.

PROCEDURE

TASK 1 : Control the speed of a slipping Induction motor by a rotor resistance starter

- 1 Check the Insulation and continuity of the motor winding.
- 2 Make the connection as per circuit diagram. (Fig 1)
- 3 Check the supply and provide proper rating fuses in the main switch according to the motor rating.
- 4 Keep the rotor resistance starter handle in the starting position (cut in) of the rotor resistance.

Cut in position of the rotor resistance is generally indicated in the starter as starting position or off position.

- 5 Press the start button of the starter, while pressing the start push button, slowly move the handle of the rotor resistance from the starting position towards the running position step by step till it settles down at run position.
- 6 Measure the speed at every step of rotor resistance and record them in Table 1.

Table 1

SI No.	Rotor Resistance Handle position	Speed in RPM

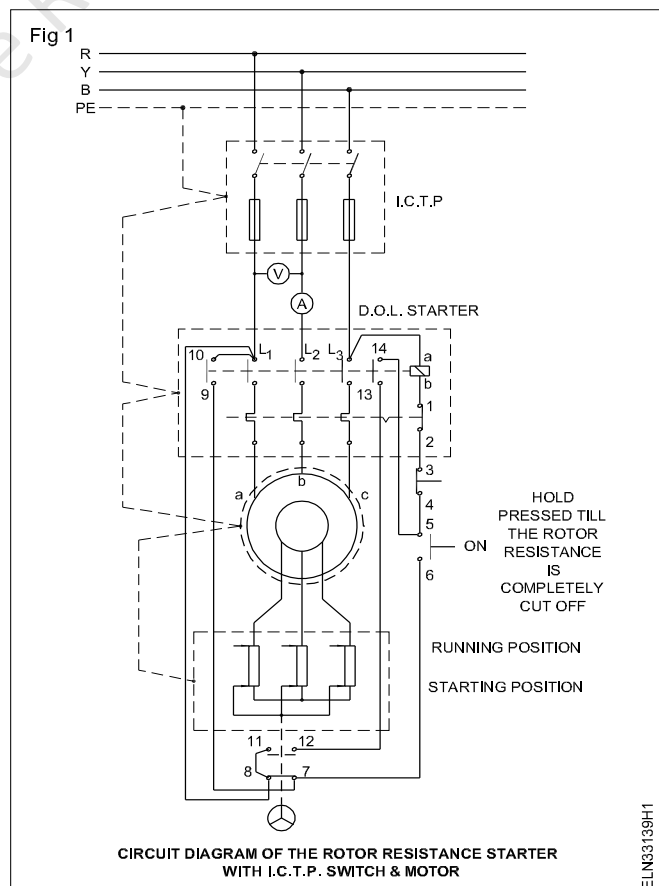

7 Release the pressure from the start push button.

8 Press the off button of the starter to stop the motor.

TASK 2 : Control the speed of 3-phase Induction motor by an auto transformer starter

- 1 Check the insulation and continuity of the motor winding.
- 2 Make connections as per diagram. (Fig 2)

- 3 Switch on the main switch 'S1' and then press start push button. (keep auto-transformer for 100V output)
- 4 Start moving the auto transformer starter contacts such that the induction motor will start getting more voltage in stages upto full voltage.
- 5 Note the speed and voltage at every stage.
- 6 Reduce the applied voltage to the induction motor by resetting the auto-transformer contacts.
- 7 Measure the rpm of the induction motor at every stage and note in Table 2.

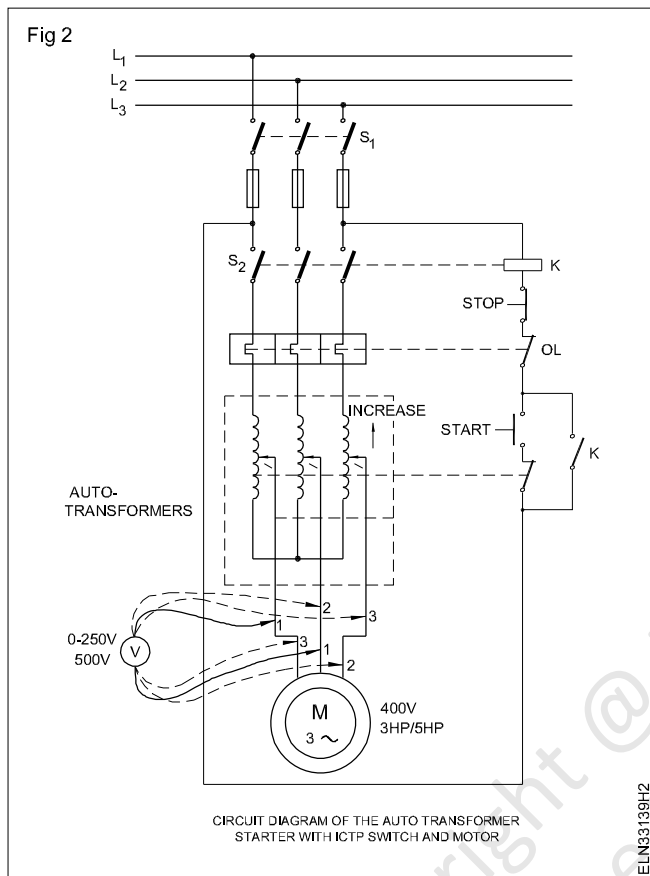

Table 2

Sl.No.	Line voltage (V1)	rpm

8 Switch off by pressing stop button and then switch off the main switch (S1)

Conclusion

State in what proportion the speed changes with respect to applied voltage to induction motor.

Get the circuit checked by the instructor before proceeding.

Perform winding of three phase AC motor by developing connection diagram, test and assemble

Objectives: At the end of this exercise you shall be able to

- **dismantle the motor**
- **read, record and interpret the winding data for a 3-phase squirrel cage induction motor**
- **strip the old winding from the stator**
- **prepare and provide slot insulation**
- **prepare and lay the coils for the distributed type winding, concentric group of coils**
- **make end connections and terminate the lead wire**
- **insulate, bind and shape the overhangs**
- **assemble the motor**
- **test the motor for performance.**

Requirements

Tools/Instruments

- Screwdriver 100, 150 and 200 mm - 1 No each
- DE spanner 5mm to 30 mm - 1 Set
- Ring spanner 5 mm to 30 mm - 1 Set
- Cold chisel 25 mm x 200 mm - 1 No.
- Ball pein hammer 500 grams - 1 No.
- Nylon mallet 75 mm x 100 mm - 1 No.
- Pulley puller 200 mm with 3 jaws - 1 No.
- Centre punch 10 mm x 150 mm - 1 No.
- Insulated cutting pliers 200 mm - 1 No.
- Side cutter 150 mm - 1 No.
- Micrometer outside 0-25 mm - 1 No.
- Hacksaw frame 300 mm - 1 No.
- Steel rule 300 mm - 1 No.
- Scissors 200 mm - 1 No.
- Fibre or Hylam knife of assorted sizes - 4 Nos.
- Soldering iron 125 W, 250V - 1 No.
- D.B.electrician knife 100 mm - 1 No.
- Multimeter - 1 No.
- Megger (insulation tester) 500V - 1 No.
- Ammeter (or multi-range) M.I. 0-10A - 1 No.
- Voltmeter M.I.Multi-range 0-300V-500V - 1 No.
- Tachometer 0-500-5000 r.p.m. - 1 No.
- Allen key - 1 Set
- Readymade former universal size - 1 Set
- Awl of required length and thickness - 1 No.
- Spatula - 1 No.
- Magnetic compass 15 mm dia. - 1 No.
- Blow lamp - 1 No.

- Electirc air blower - 1 No.

Equipment/Machines

- Burnt out 3-phase motor with single layer distributed winding of available capacity & double layer - 1 No.
- Baking oven with temperature control - 1 No.
- Coil winding machine - 1 No.
- Burnt out 3 phase motor with single layer concentric half coil winding - 1 No.

Materials

- Super-enamelled copper wire - as reqd.
- Milinex sheet or triplex paper - as reqd.
- 20 or 25 mm cotton tape - 1 Roll
- Fibre glass sleeves 1 mm, 2 mm, 4 mm, 6 mm - as reqd.
- Bamboo/fibre wedges - as reqd.
- 25 mm painting brush - 1 No.
- Soldering lead 60%, Tin 40%, - 100 g
- Resin flux - 25 g
- Insulating varnish - 1 litre.
- Tray 600 mm x 600 mm x 100 mm - 1 No.
- Thinner - 500 ml
- Hemp thread - 1 Roll
- Used power hacksaw blade - 2 Nos.
- Leatheroid paper - as reqd.
- Empire sleeve - as reqd.

PROCEDURE

Instructor may select a motor having burnt out single layer distributed winding for this exercise.

TASK 1 : Dismantling of the motor, recording winding data and stripping the winding

- 1 Collect the name-plate details and record in Table 1.
- 2 Calculate the number of poles from the name-plate details.

Using the formula $P = \frac{120 \times f}{N_s}$

where P - number of poles

f - frequency in Hertz

N_s - synchronous speed in r.p.m.

(little higher than the rotor speed noted in the name-plate).

3 Enter the number of poles in Table 2.

Table 1

Induction motor name-plate details

Make	Frame No.....	Model
Phase	Kilo watt	r.p.m
Volts.....	Amperes	Frequency
Rating		Insulation
Connection.....Star/Delta		Class

Table 2

Winding Data

No.of coils	No.of slots.....	Coil pitch
No.of Poles		
Overhang projection	a) connection end	mm
	b) Non-connection end	mm

Alternatively calculate the poles using the rated rotor speed and round off the value to full number.

4 Remove the shaft key or the grub screw by holding the pulley. (Fig 1)

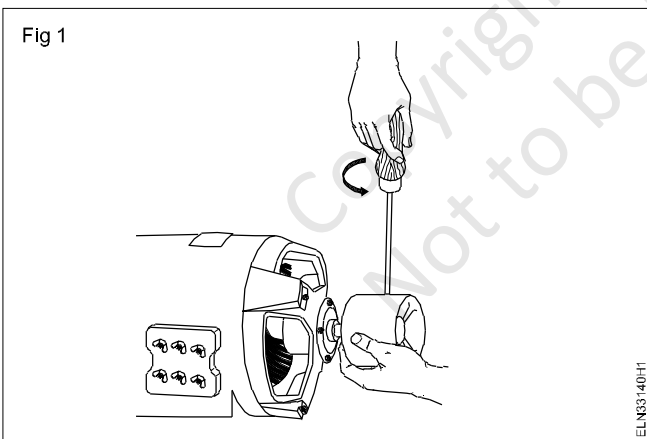

5 Remove the pulley by using a suitable pulley puller. (Fig 2)

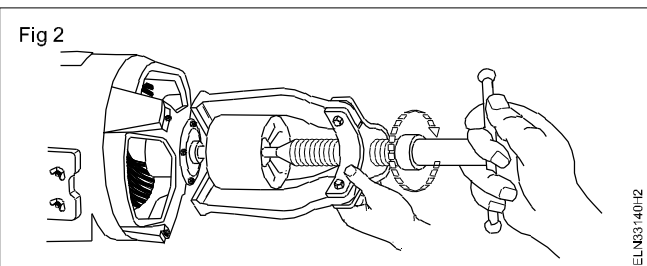

6 Make a centre punch alignment mark on the stator and the end shield cover. (Fig 3)

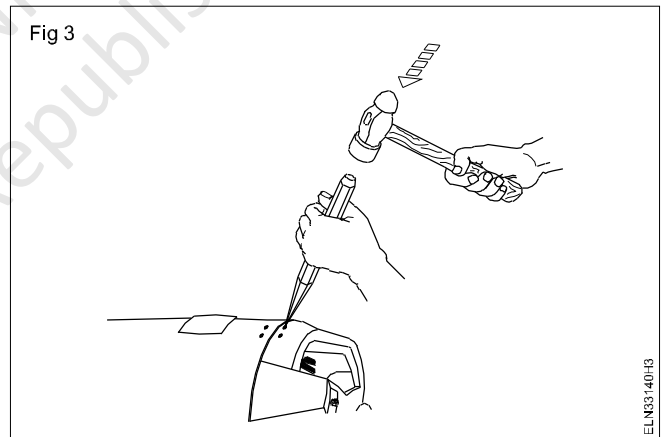

To avoid confusion make a single punch mark on one side and a dual punch mark on the other end of the motor.

7 Remove the grease cup screw.

8 Loosen the bolts gradually, switching from side to side till they are removed. (Fig 4)

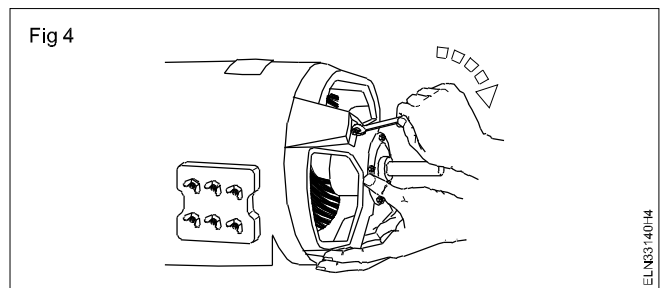

9 Keep the cold chisel tip between the stator and cover and gently tap the chisel with a hammer and separate the stator and the end shield cover. (Fig 5)

Fig 5

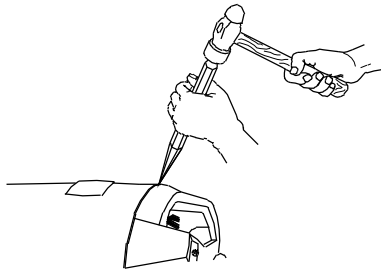

ELN33140H5

10 Pull off the end shield cover and rotor together, parallel to the motor shaft. (Fig 6)

Fig 6

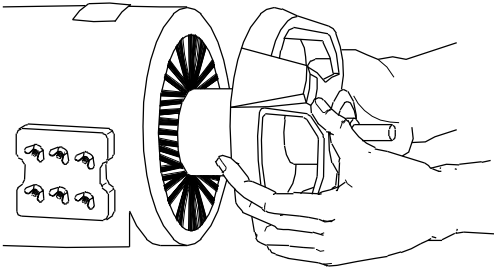

ELN33140H6

11 Hold the shaft in one hand, rotate the end cover and tap it lightly with a nylon mallet to remove it from the rotor. (Fig 7)

Fig 7

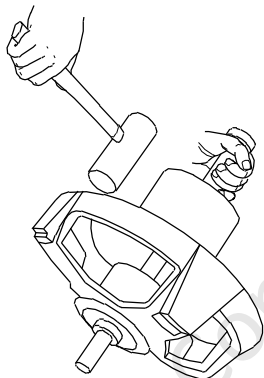

ELN33140H7

12 Remove the other end shield cover also by gently priming it out.

13 Inspect the rotor for any defect and the bearing for its condition.

If the bearing is worn out replace it with a new one. All fastening devices should be kept in a separate tray. The dismantle parts are shown in Fig 8.

Fig 8

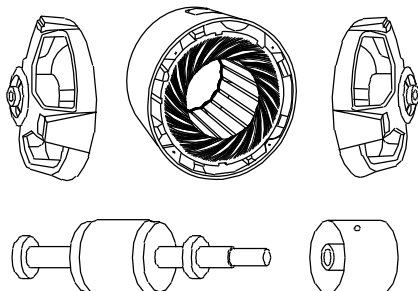

ELN33140H8

14 Identify whether the winding is a single layer distributed type.

In a single layer distributed type winding, the number of coils is equal to half the number of slots and the same size of coils are used throughout the winding.

15 Record the number of coils, number of poles, number of slots, pitch and record the overhand projection at both ends of the stator in table 2 and if required prepare templates by cardboard or similar materials for overhang projection. This will help to check the overhangs after rewinding.

16 Open the end binding of the end and lead connections from the overhang.

17 Trace the group/lead connections and draw the same for reference in your record.

The number of coil groups shall be equal to the number of phase x number of poles in the case of whole coil connection whereas in the case of half coil connection the number of coil groups shall be equal to the number of phases x pair of poles. Hence ascertain the group and connection.

18 Remove the wedges. The wedge can be removed by using a power hacksaw blade as shown in Fig 9 or by a wedge remover.

Fig 9

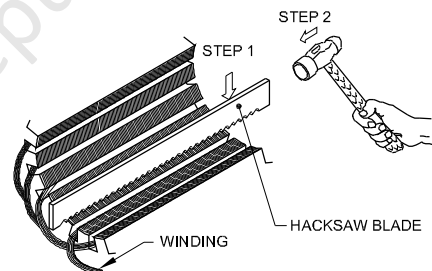

ELN33140H9

19 Cut off the coils in the non-connection end of the stator with a chisel. (Fig 10)

Fig 10

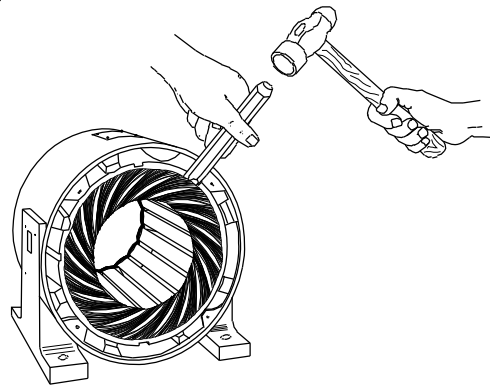

ELN33140HA

20 Pull out the coils with pincers or pliers. (Fig 11)

Fig 11

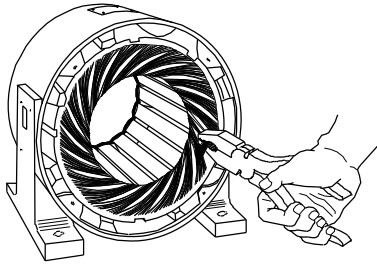

ELN83140JIB

In case the varnish on the winding is hard, heat the winding in an oven to about 200°C for about one hour or heat it by a blowlamp. While heating it is important that the heat should be controlled such that the excess heat will not damage the stampings and warp the frame or core. In the case of loose coils, cutting of the coils may not be required and it can be removed out through the slots.

- 21 Check, record the total weight of the coils, count the number of turns, measure the size of the wire, and record them in Table 3.

Some manufacturers may use parallel conductors of the same size or different sizes of wires instead of using a single wire. Take care of this while recording and entering the details in Table 3 against 'wire multiple'.

- 22 Remove all the remaining foreign matter from the slots by scraping with a knife.
- 23 Clean it by blowing compressed air.
- 24 Measure the size and shape of the coil. If the full shape of the coil is available record the details in Table 4.

In case the full shape of the coil is not available, prepare a trial coil of single turn and insert it in the slots at the given pitches. Verify the overhang projection, clearance, correct size etc.

Table 3

No. of circuits.....	Turns/Coils.....	Size of the wire.....
Wire multiple.....	Wt.of scrap.....	Wire insulation.....

Table 4

Coil shape: Diamond / Rectangular / Oval	
A.	Coil length mm
B.	Coil width mm

TASK 2 : Prepare and provide slot insulation

- 1 Check the slot dimension and record it in Table 5.
- 2 Check the core thickness and record the same in Table 5.
- 3 Select the slot liner of thickness as in the original.
- 4 Cut the paper as per slot length/core thickness with an additional length of 10 to 15 mm so as to make the insulation paper to project 5 mm on either side of the slot with cuffed ends.

10 to 15mm on either side is just an approximate requirement. Large motors may require a longer length or vice versa.

- 5 Cuff either end of the slot liner (Fig 12) and fold the same to the slot size.

Fig 12

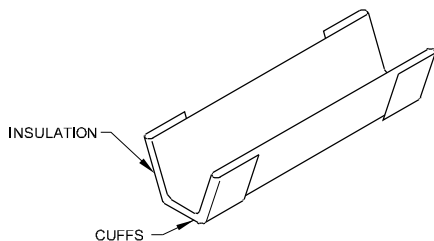

ELN83140HC

Prepare a sample of the slot liner and try inserting it in the slot to see the correctness.

- 6 Cut and prepare the necessary number of slot liners as per the correct sample.
- 7 Insert the slot liners in all the slots properly and see that the slot liners project evenly on both sides of the core. (Fig 13)

Fig 13

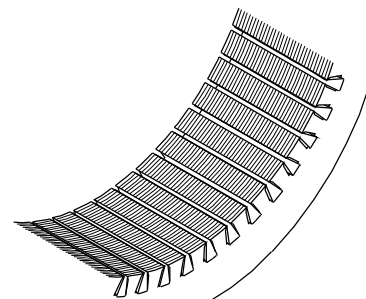

ELN83140HD

The slot liner should properly adhere to the surface of the slots as shown in Fig 14(a). A wrong method of placing the slot liner. (Fig 14b).

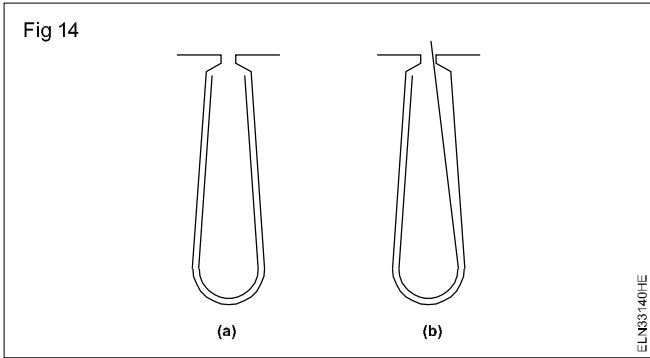

8 Check the group/lead connections drawn in step 17 of Task 1 and also draw the developed diagram of the winding for the given motor.

For your guidance the end connections and the developed diagram are given in Figs 15 and 16 respectively for a certain motor having a single layer distributed type winding with the following data: 24 slots, 12 coils, 4 poles, 3-phase balanced winding.

Table 5

Slot dimension

Lower width	mm
Upper width (W)	mm
Depth	mm
Slot length	mm

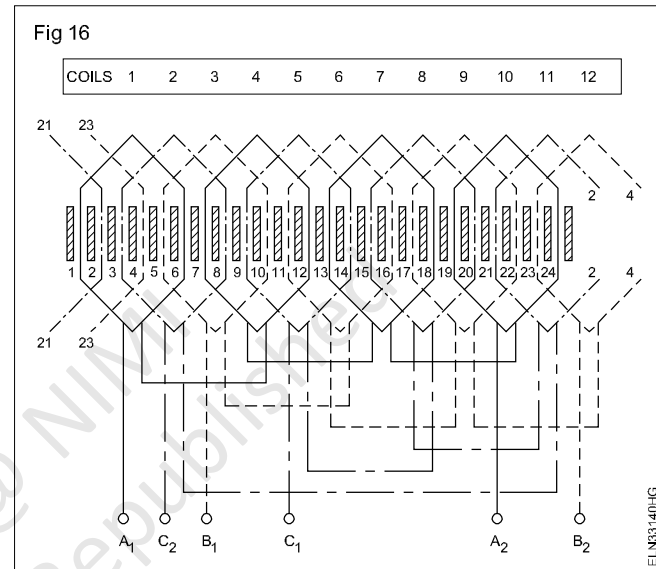
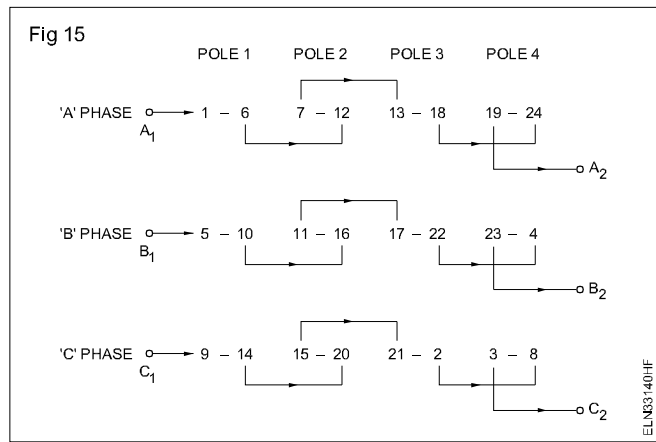

TASK 3 : Prepare coil winding and forming

1 Select a suitable size of former according to the dimension recorded in Table 4.

The former is cut with a distinct bevel edge for two reasons: to permit the coil to slip off the former and to allow a longer peripheral length of the coil at the back. Only one size of former is sufficient for the distributed type of winding.

2 Attach the former securely to the winding stand. (Fig 17) .

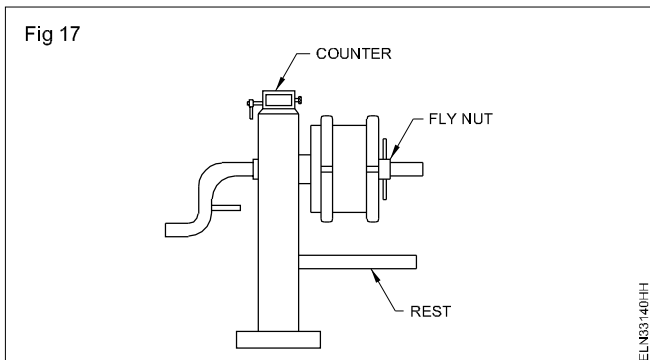

3 Confirm and select the size of winding wire i.e. given in Table 3.

4 Wind the designated number of turns (Table 3) by leaving 150 mm extension wire.

Make sure the number of turns is small as in the original.

5 Tie the coil tightly with twine thread on either side of the coil, after winding the coil.

6 Cut the remaining length of wire by leaving 150 mm extension.

7 Remove the coil from the former and check its correctness by inserting in the slots.

If the size is found OK proceed to step 8. Otherwise make necessary changes in the former till the coil shape is correct.

8 Make the required number of coils.

9 Shape the coils by folding the ends of the straight parts of the coils. (Fig 18)

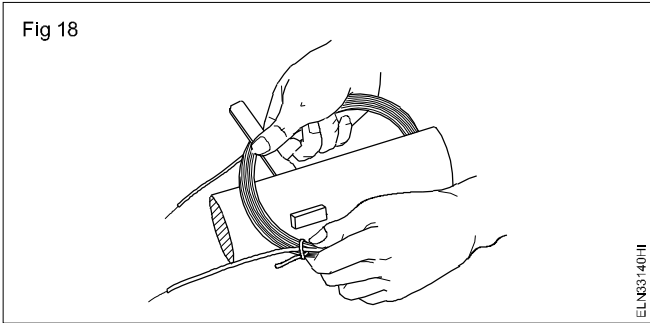

TASK 4 : Insert the coils in the slots in proper sequence

Procedure for 24 slots, 12 coils, 4 pole distributed winding is given below. You can adopt the same procedure for other stators of different slots and poles with necessary modification. Observe keenly the developed diagram shown in Fig 16.

- 1 Follow the procedure given below. First insert the left coil sides of 1st coil, 2nd coil and 3rd coil in slot 1, 3 and 5 respectively. (Fig 19)

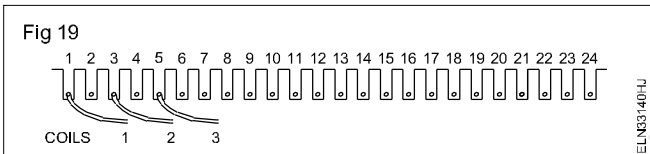

- 2 Insert the right coil side of the 1st coil in slot number 6. (Fig 20)

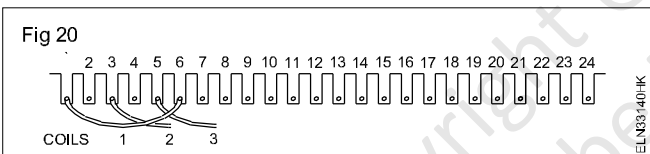

- 3 Insert the left coil side of coil 4 in slot 7 (Fig 21) and then insert the right coil side of coil 2 in slot 8. (Fig 22)

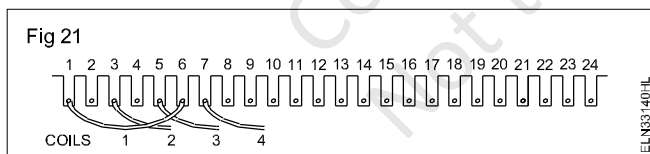

- 4 Insert left coil side of coil 5 in slot 9 and then insert the right coil side of coil 3 in slot 10. (Fig 23)

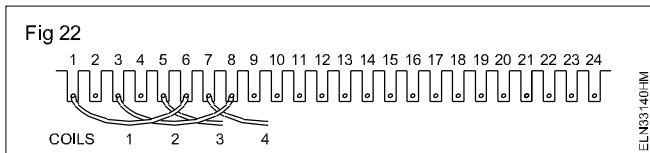

- 5 Proceed likewise till you are left with the right coil sides of coils 11 and 12.

- 6 Insert the 11th coil right coil side in slot 2 and then the 12th coil right coil side in slot 4. (Fig 24)

- 7 Insert the wedges in the slots so that the coil sides are well packed in the slots. (Fig 25)

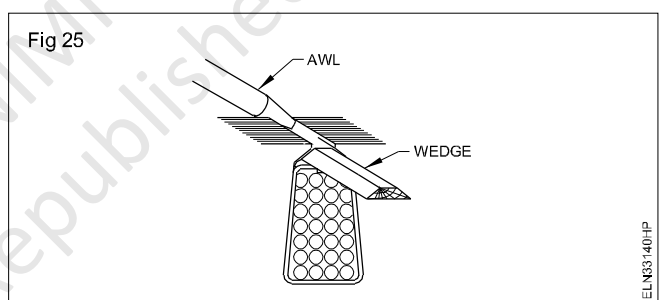
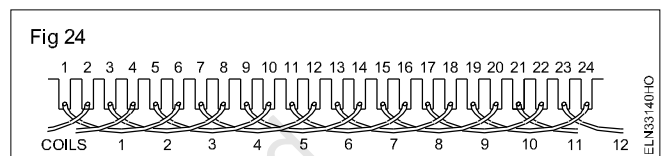
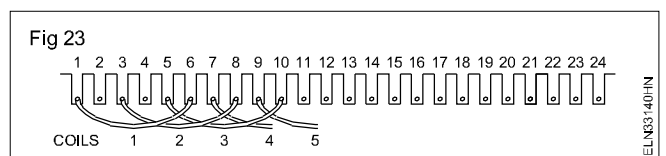

- 8 Insert the half moon shaped phase insulation paper between each coil in both sides of the overhang.
- 9 Follow the developed diagram and connect the end, group and terminal connections.
- 10 Tie the connections with overhangs and shape the overhang.
- 11 Test the winding .
- 12 Measure the resistance between $A_1 - A_2$, $B_1 - B_2$ and $C_1 - C_2$ and record the values in Table 6.

Table 6

Resistance between A1 - A2	ohm
Resistance between B1 - B2	ohm
Resistance between C1 - C2	ohm

All the three resistances should be equal.

- 13 Measure the insulation resistance between the windings and the stator core with 500 V Megger and record it in Table 7.

Table 7

Insulation resistance

between core and A phase.....MEGOHM
 between core and C phase.....MEGOHM
 between core and B phase.....MEGOHM

14 Measure the insulation resistance between the windings with a 500V Megger and record it in Table 8.

The above values should not be less than one megohm in any case.

Table 8

Insulation Resistance

Between A phase and B phase...MEGOHM
 Between B phase and C phase...MEGOHM
 Between C phase and A phase...MEGOHM

15 Varnish the winding,

16 Assemble the motor and test run the motor with load for 8 hours.

The instructor should select a 3-phase induction motor having a single layer concentric (half coil) winding for this exercise.

TASK 5 : Record winding data and strip the winding

- 1 Collect the name-plate data and record in Table 9.
- 2 From the name-plate details, calculate the number of poles and write it below.
 Number of poles.....
- 3 Dismantle the given motor. Record the details of the existing winding details before and after removing the coils from the stator in Table 13.
- 4 Identify the windings of the given motor - whether it is single layer concentric winding.

Table 9

Induction motor

MakeFrame No.Model
 PhaseKilowatt/HPr.p.m
 VoltsAmperesFrequeency.....

In single layer winding, the number of coils is equal to half the number of slots. In concentric winding the pitch of coils in the group will be different and will be in concentric form.

5 Record the number of slots, number of coils and the pitch of the coils in Table10

Table 10

No. of slots No. of coilsCoil Pitch
 No. of poles..... No. of coils/slot
 End connections(Half coil/whole coil)

6 Trace the group/lead connections and draw the same for reference in the space given.

In whole coil connected winding, the total number of groups shall be equal to the number of phases multiplied by the number of poles, and in the case of half coil connected winding, the total number of groups shall be equal to the number of phases multiplied by the number of pairs of poles. Hence ascertain the number of groups, and, thereby, the type of connection.

- 7 Record the length of the overhang projection and prepare a template which could be used to check the overhangs after rewinding.
- 8 Remove the wedges from the slots.
- 9 Strip all the coils out from the stator except one complete group of coils.
- 10 Use a thinner in the winding and remove carefully one complete group of coils without damage.
- 11 Check the total coil weight and record it in Table 11.

Table 11

No. of circuits.....Turns/coil.....
 a)
 b)
 c)
 Size of the wire.....Wire multiple.....
 Total weight of scraped coils.....Wire insulation.....

12 Clean the stator slots.

13 Using the complete set of coils, measure the size and shape of the coils and record the details in Table 12.

Table 12

Shape of the coil.....diamond/Rectangular/Oval

	Outer coil	Inner coil
A	Coil length mmmm
B	Coil width mmmm
C	Coil thickness m	

In case the full shape of a coil is not available, use a single turn of 16 or 18 SWG copper wire and measure the inner dimensions of the coils of the coils of the set, one after the other. Insert it in the slots at the given pitches. Verify the length of overhang projection and clearance etc. taking into account the thickness of the coils. If found satisfactory, use the same for recording the measurement.

TASK 6 : Prepare slot insulation

- 1 Prepare slot liners and insulate the slots.

TASK 7: Prepare stepped former and coils

- 1 Select a suitable sized former according to the dimensions recorded in Table 12.
- 2 Set the adjustable stepped former to the dimensions of the coils taken as data from Table 12.
- 3 Wind the designated number of turns in each coil of the group by referring to table 3. Leave about 150mm in the starting end of the coil for connection.
- 4 Tie the turns of the coil tightly with twine thread on either side of the coil after winding.

- 5 Cut the remaining length of wire leaving 150 mm extension.
- 6 Remove the coil from the former, without damage.

Wind one set of coils of the group for trial and verify the size with the stripped out coils. Preferably insert one set of groups of coils in the assigned slots in the stator and check the correctness with respect to overhand etc.

- 7 Wind the required number of coil groups similarly .
- 8 Shape the coils by folding the ends in the straight part of the coils.

TASK 8 : Lay coils in the slots

The Procedure for 24 slots, 12 coils, 4 poles, single layer concentric winding (half coil) is given below. You can adopt the same procedure for the other stators of different slots and poles with necessary modifications.

The end connection and developed diagrams for the above stated winding are given in Fig 26 and 27 for your guidance.

In the concentric type of winding the insertion of coils should start from the inner coil which is having the shortest pitch.

- 2 Check the connection side of the winding with respect to the stator and hold the connection end of the coil in that side.
- 3 Place a leatheroid paper of length equal to the width of the core in the right side of the core. (Fig 28).

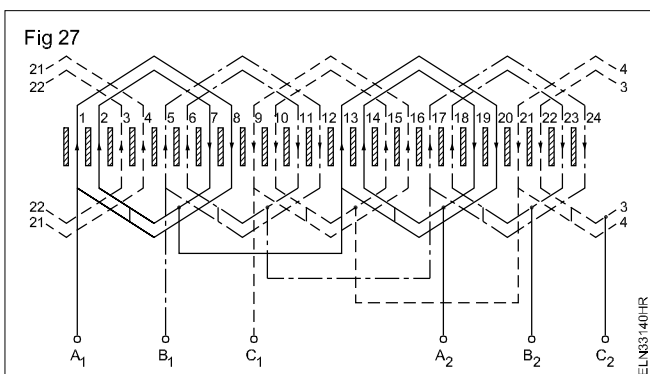
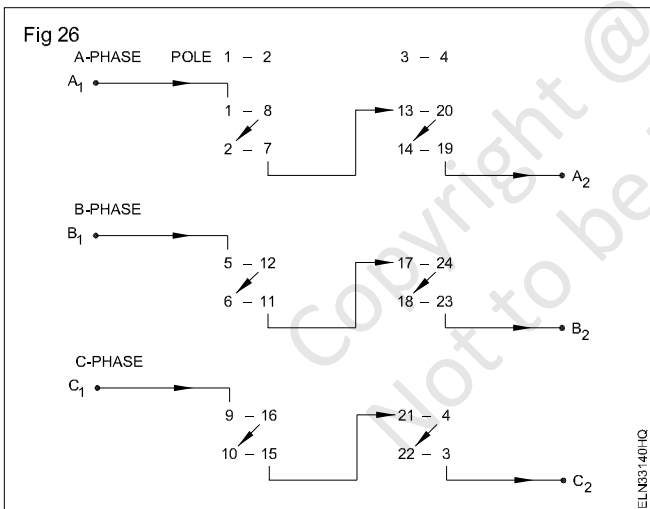

- 1 Insert the guide papers in the grooves of slot No.2 (Fig 27) where the winding will begin.

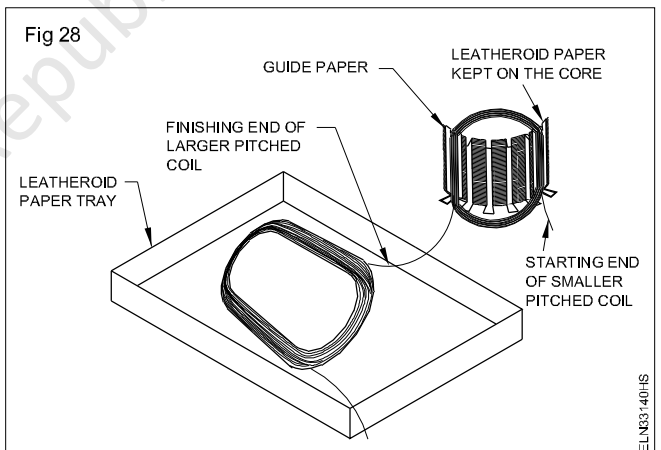

To avoid insulation damage to the winding wires, check at intervals the position of the leatheroid paper which is kept on the core between the right coil side and the core

- 4 Separate the inner coil from the group, hold the smaller coil in hand and keep the larger coil in front of the stator in a leatheroid paper tray. (Fig 28)
- 5 Insert the left coil side of the smaller coil in slot No. 2. (Fig 28)
- 6 Remove the guide papers and insert them in slot No. 7.
- 7 Insert the right coil side of the smaller coil in slot No. 7.
- 8 Remove the guide papers from slot No. 7 and insert them in slot No. 1.

- 9 Insert the left coil side of the larger coil in slot No. 1
- 10 Remove the guide papers and insert in slot No. 8 and then insert the right coil side of the larger coil in slot No. 8.

See to it that the current direction in the group is correct according to the developed diagram.

- 11 Insert the 2nd coil group having smaller and larger coils in slot No. 6, 11, 5 and 12 respectively.

- 12 Insert likewise 3rd, 4th, 5th and 6th coil groups in the respective slots. (Refer to the developed diagram)
- 13 Insert a separate paper in all the slots over the inserted coils.
- 14 Fold the slot liner and insert the wedge in all the slots.
- 15 Insert a half moon shaped insulation paper as phase insulator between the coils on either side of the overhang.

TASK 9 : Connect the coil groups

- 1 Connect the group connections of the same phase and solder them according to the end connection and developed diagrams (Fig 26 and 27). Sleeve the joints.
- 2 Connect the phase leads with the coil groups and insert the sleeve over the joints.

- 3 Use a nylon mallet and shape the overhang to the original size.

Check the size of the overhang with the help of overhang template.

- 4 Tie the hemp thread to bind the soldered joints along with the overhang.

TASK 10 : Test the winding

- 1 Test the winding by megger continuity, short and insulation resistance test and note down results. (Task : 1, 2, 3 exercise 3.3.138)

TASK 11 : Varnish the windings

- 1 Varnish the winding .
- 2 Dry the moisture by using lamp loads.
- 3 Check the varnish dry level.

TASK 12: Test and assemble the motor

- 1 Test and run the motor to ascertain its performance. (Steps 18 to 31 exercise 3.1.33)

TASK 13 : Calculate winding for the developed diagram

For easy understanding of the steps a 24 slots, 24 coil, 4-pole, 3-phase motor is considered as an example. For the motor given as an example winding calculations are as under.

$$1 \text{ No. of coils / phase} = \frac{\text{Total No. of coils}}{\text{No. of phases}} = \frac{24}{3}$$

= 8 coils/phase.

$$2 \text{ No. of coils / phase / pole} =$$

$$= \frac{\text{Total No. of coils}}{\text{No. of phases} \times \text{No. of poles}}$$

$$= \frac{24}{4 \times 3} = 2 \text{ coils / phase / pole.}$$

$$3 \text{ Pole pitch} = \frac{\text{No. of slots}}{\text{No. of poles}} = \frac{24}{4} = 6 \text{ slots / pole}$$

- 4 Coil pitch possible

A	5 (1 to 6) Short chorded
B	6 (1 to 7) Full pitched

C 7 (1 to 8) Long chorded

- 5 Coil pitch selected = 5 (1 to 6)

- 6 Coil pitch selected is short chorded.

- 7 Total electrical degrees = $180^\circ \times \text{No. of poles}$
 $= 180^\circ \times 4 = 720^\circ$

$$\text{Slot distance in degrees} = \frac{\text{Total electrical degrees}}{\text{No. of slots}}$$

$$= \frac{720}{24} = 30$$

- 9 Req'd displacement between phase in terms of slots =

$$\frac{120}{\text{Slot distance in degrees}}$$

$$= \frac{120}{30} = 4 \text{ slots}$$

10 Winding sequence

If 1st phase starts in the 1st slot.

2nd phase starts in the (1+4) i.e in 5th slot.

3rd phase starts in the (5+4) i.e in 9th slot.

11 Arrangement of coils

The coils are to be arranged in the slots in the sequence:

1-6, 2-7, 3-8, 4-9, 5-10, 6-11, 7-12, 8-13, 9-14, 10-15, 11-16, 12-17, 13-18, 14-19, 15-20, 16-21, 17-22, 18-23, 19-24, 20-1, 21-2, 22-3, 23-4, 24-5.

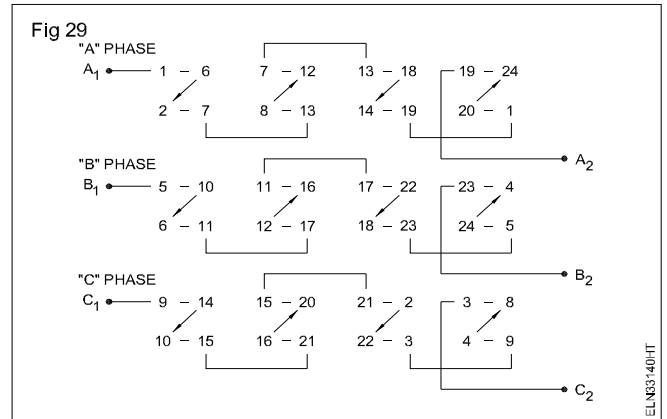

Fig 29 and 30 show the connection diagram and developed diagram for the above motor.

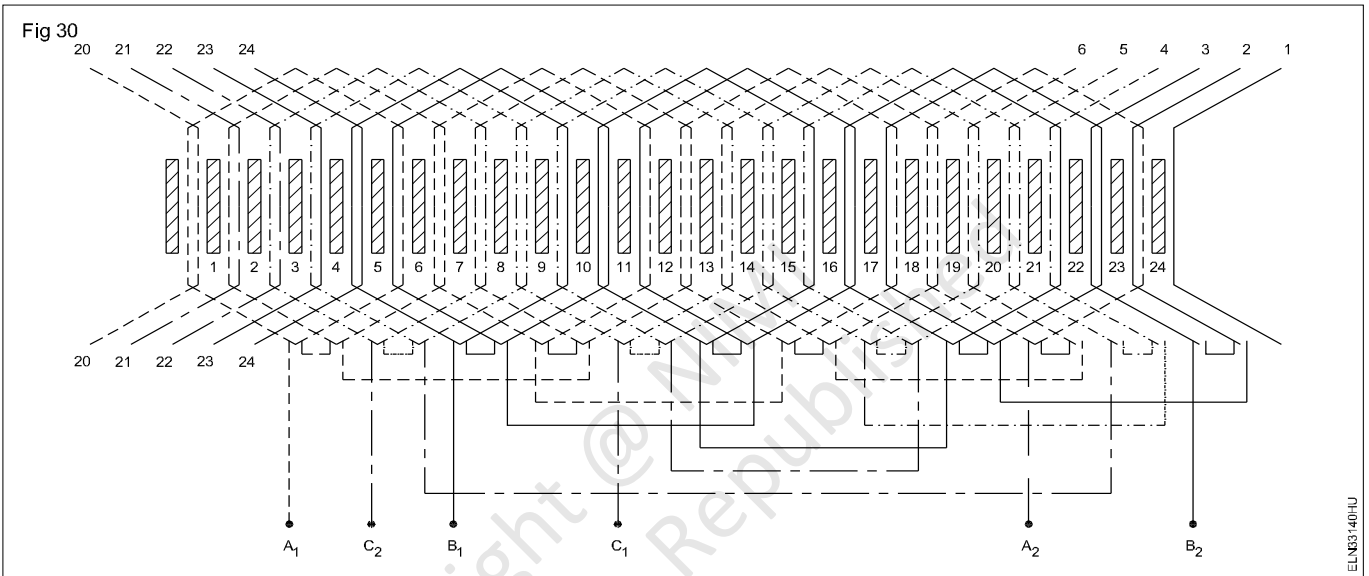

Table 13

Data to be taken from the stator (before removing the coils)

- No. of slotsNo. of coils Coils per group
- Group connectors Wire insulation
- Coil throw Type of windingDistribution/Concentric
- Wedge material Size Binding materialSize
- Overhang dimension Outer dia.mm Inner dia.mm
- Lengthmm Shape (make template).

Data to be taken (after removing the coils)

- Size of wiremm No. of parallel wires No. of turns
- Size of coil lengthmm(inside) widthmm(inside) Thicknessmm
- Type of sleeve size Type of lead size
- 1
- 2
- 3
- Slot insulation Type Thickness Dimension
- Type of coilNumber of coils
- Weight of single coilWeight of the total winding
- Front end bearing numberRear end bearing number
- Size of connection lead
- Connection lead side with respect to terminal box

With the reference given in the winding calculations fill up the winding data for the motor given to you.

- 1 No. of coils / phase = $\frac{\text{Total No. of coils}}{\text{No. of phases}}$
= coils/phase
- 2 No. of coils / phases / poles
= $\frac{\text{Total No. of Coils}}{\text{No. of phases} \times \text{No. of poles}}$
= slots/poles
- 3 Pole pitch = $\frac{\text{No. of slots}}{\text{No. of poles}}$ = slots / poles
- 4 Coil pitch possible A)
B)
C)
- 5 Coil pitch as per the data collected is
- 6 Coil pitch selected is

(short chorded/full pitched/long chorded)

- 7 Total electrical degrees = $180^\circ \times \text{No. of poles}$
= $180^\circ \times \dots\dots = \dots\dots$
- 8 Slot distance in degrees = $\frac{\text{Total electrical degrees}}{\text{No. of slots}}$
- 9 Req'd. displacement between phases in terms of slots
= $\frac{120}{\text{Slot distance in degrees}}$
- 10 Winding sequence
1st phase starts in the
2nd phase starts in the
3rd phase starts in the
- 11 Arrangement of coils
The coils are to be arranged in the sequence.

Draw the connection diagram and the developed diagram for the motor given to you, on a separate paper.

TASK 14 : Prepare the stator to receive the winding

- 1 Set the core, if it is mangled (lightly tap with a nylon mallet to correct the core) and clean the slot to remove any old insulation paper.
- 2 Select the insulation paper of the same grade and thickness or its equivalent as in the original and cut the insulation paper to the same size.

Slot insulation paper must be approximately 10 to 15 mm longer than the slot length and is to be formed according to the shapes of the inner walls of the slot. The ends of the insulation are often cuffed to avoid the insulation paper from sliding off from its position.

TASK 15 : Prepare coils

- 1 Make a ganged former or select a readymade former according the old coil size. (Figs 31 and 32)

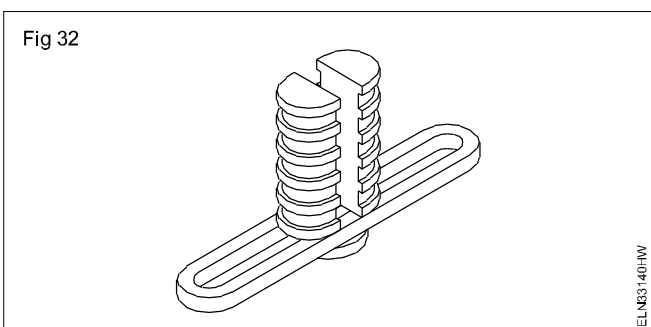
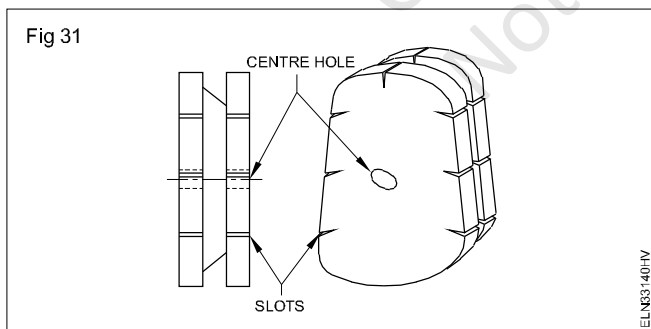

- 2 Select the correct size of winding wire as per the data taken.
- 3 Attach the former to the winding machine, wind the designated turns and make one set of ganged coils.
- 4 Insert the ganged coils in the designated slots and check their correctness.

While checking make sure that the coils are of the correct dimension so that the two coil sides could be accommodated as top and bottom coil sides in the same slot of the double layer winding, and the overhang dimensions are comparable to the template (as in the original).

- 5 Make necessary sets of ganged coils, if coil dimensions are correct

In the example given, two coils are forming the gang. Choose the former according to the number of gang coils.

TASK 16 : Lay coils in double layer winding (Fig 30)

Carefully examine the developed diagram in which the slot pitch is given as 1-6 and there will be two coils in a group. The left coil side of coil 1 is in slot 1 as bottom coil and the right coil side of coil 1 is in slot 6 as top coil. In double layer winding the coil sides should be placed in adjacent slots. Modify the procedure to suit the requirement of the given motor winding.

- 1 Insert the left coil sides of the first set of ganged coils in slots 1 and 2.
- 2 Leave the right coil sides of the ganged coils over the stator with a leatheroid insulation paper between the coil sides and core.

- 3 Insert likewise two more sets of ganged coils in slot numbers 3,4,5 and 6 like step 1 and 2. (Fig 33).

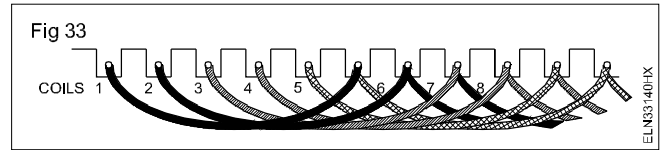

- 4 Place a separator insulation over the bottom coils side of slot 6.
- 5 Insert the right coil side of the 1st coil in slot number 6 as the top coil side.

TASK 17: Connect group leads - testing and varnishing

- 1 Bring out the group ends, connect, solder and insulate the groups. (Fig 34)

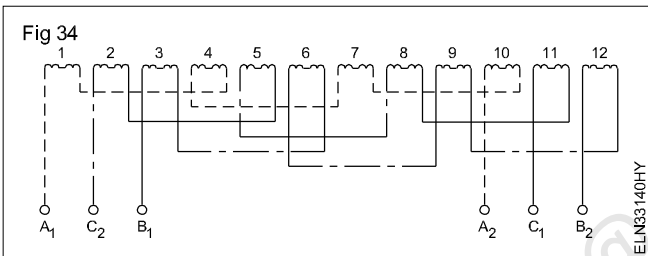

- 2 Connect the lead cables to the group connections and solder them.

- 3 Tie the hemp threads in the overhangs, to secure the sleeved joints and phase separator insulations.
- 4 Shape the overhangs and check with a template.
- 5 Test the winding for continuity and ground as per Exercise 3.3.138.
- 6 Assemble the motor if the test results are satisfactory and run it for ten minutes.
- 7 Dismantle the motor, impregnate the windings and dry them, if the results are O.K.
- 8 Assemble and test the motor on load.

Maintain, service and troubleshoot the AC motor starter

Objectives: At the end of this exercise you shall be able to

- identify the parts of the AC starters
- trace and draw the schematic diagram of the starters
- check volt coil, moving contactors, fixed contactors, NC and NO
- set the over load relay and timer.

Requirements	
<p>Tools/Instruments</p> <ul style="list-style-type: none"> • Combination pliers 200 mm - 1 No. • Screw driver 200mm - 1 No. • Multimeter - 1 No. • Megger 500V - 1 No. <p>Equipments/Machines</p> <ul style="list-style-type: none"> • D.O.L Starter - 1 No. • Star Delta starter - 1 No. • Rotor resistance starter - 1 No. • Auto transformer starter - 1 No. 	<p>Materials</p> <ul style="list-style-type: none"> • PVC insulated, stranded aluminium cable 2.5 sq. mm 650V grade - 25 m • Fuse wire 10 amps - as reqd. • Black insulation tape - as reqd. • ICDP switch 16A 500V - 1 No. • TPIC switch 16A - 500V - 1 No. • Push button station - 1 No. • Over load relay - 1 No. • Contactor - 1 No. • Time delay relay - 1 No.

PROCEDURE

TASK 1: Check and service AC motor starters

- 1 Identify the parts of AC starters, like contactor, unit, overload relay unit, start/stop push button unit, necessary fixing screws, hook up cables, starter base cover and timer. (Fig 1, 2, 3 & 4)

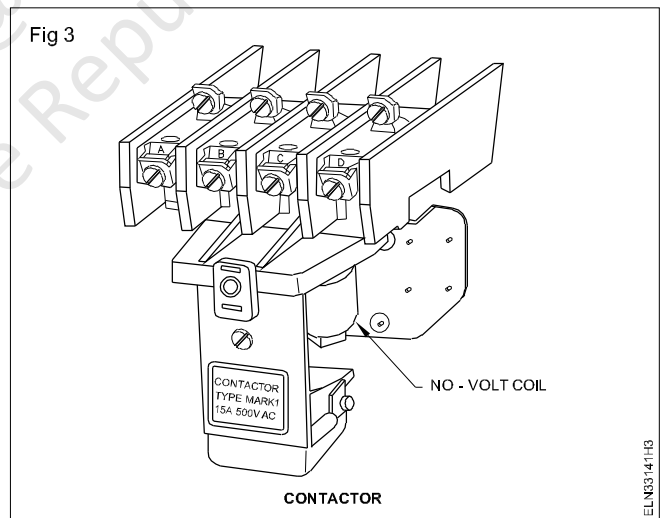
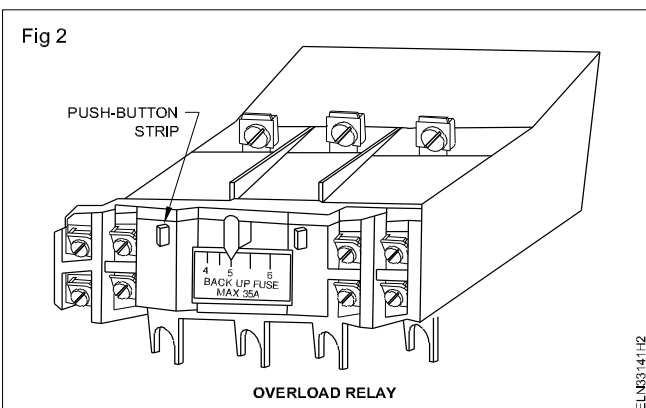
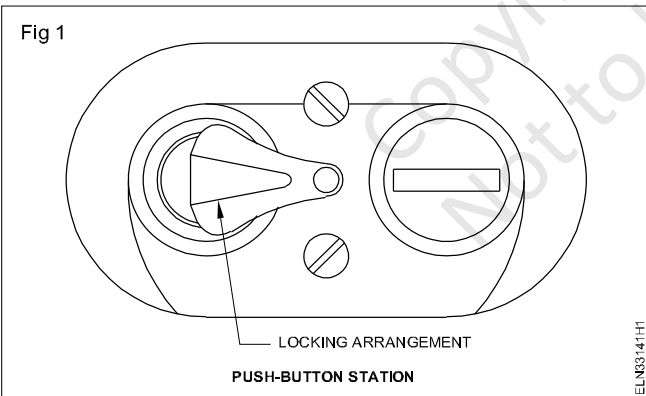

- 2 Investigate and check the contactors input and output terminals, auxiliary and main terminals, movable and fixed contacts, no volt coil, over load relay, their rating, normally closed relay contacts and their operation.
- 3 Identify the connecting terminals for inter connecting no volt coil, main supply to control circuit, normally open auxiliary contacts.
- 4 Draw the complete circuit diagram for D.O.L starter, star delta starter, rotor resistance starter and auto transformer starter. (Fig 5, 6, 7 & 8)
- 5 Get the diagram approved by the instructor.
- 6 Follow the trouble shoot chart -.

Fig 4

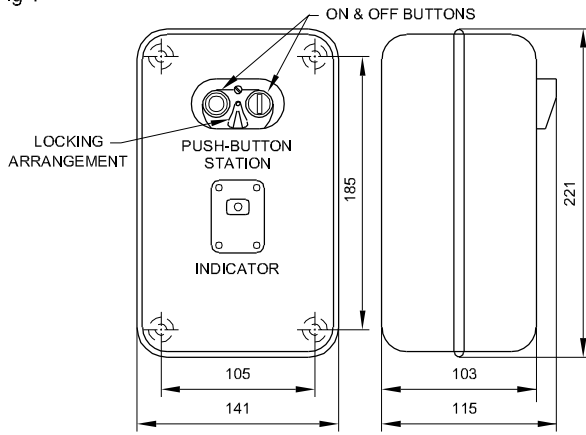

ALL DIMENSIONS ARE IN mm.

DIMENSIONS OF BASE AND COVER OF DOL STARTER

ELN83141H4

Do not tighten the screws more than necessary as too much tightening of screws will break the PVC casing of the contactor and OL relay.

A complete diagram showing the internal diagram of a starter of a particular make along with I.C.T.P and motor is given for your guidance. You can replace the internal diagram of the given starter in the place of the starter diagram shown in Fig 5.

Fig 5

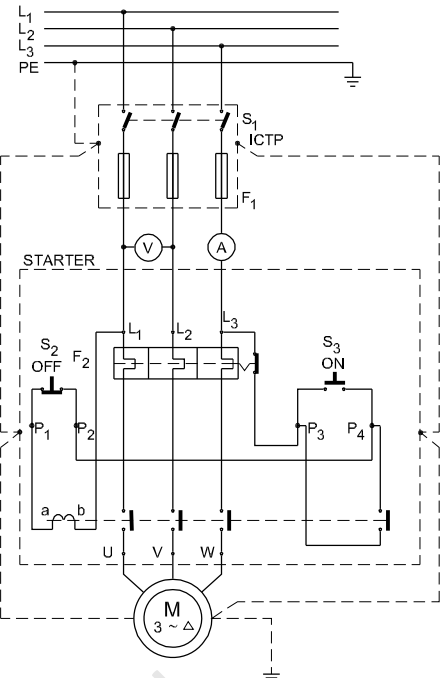

CIRCUIT DIAGRAM OF DOL STARTER WITH PROTECTIVE DEVICE

ELN83141H5

Fig 6

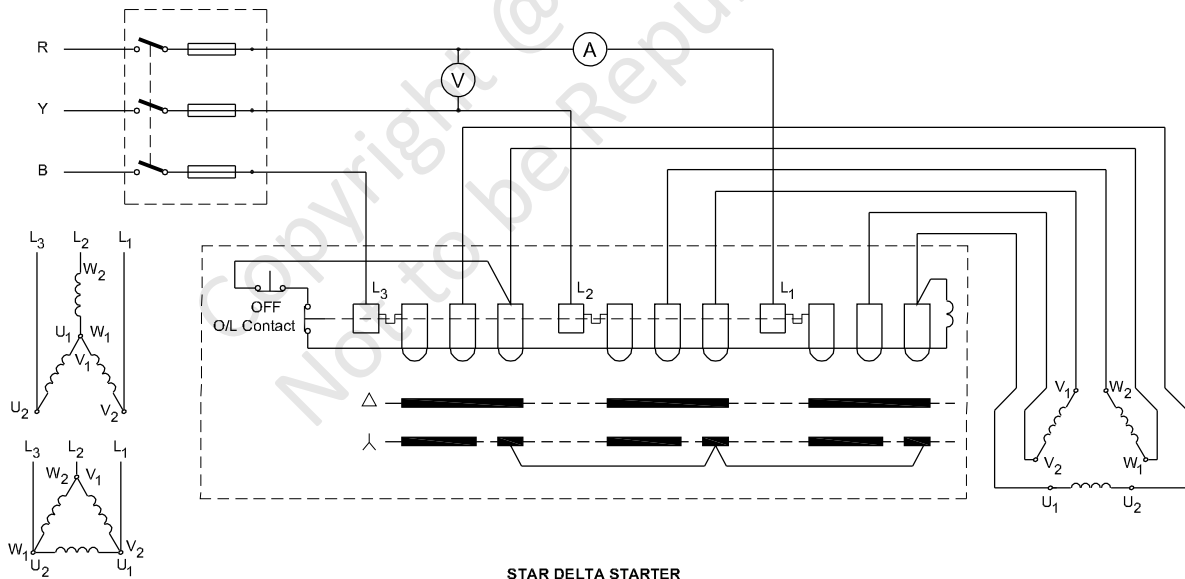

STAR DELTA STARTER

ELN83141H6

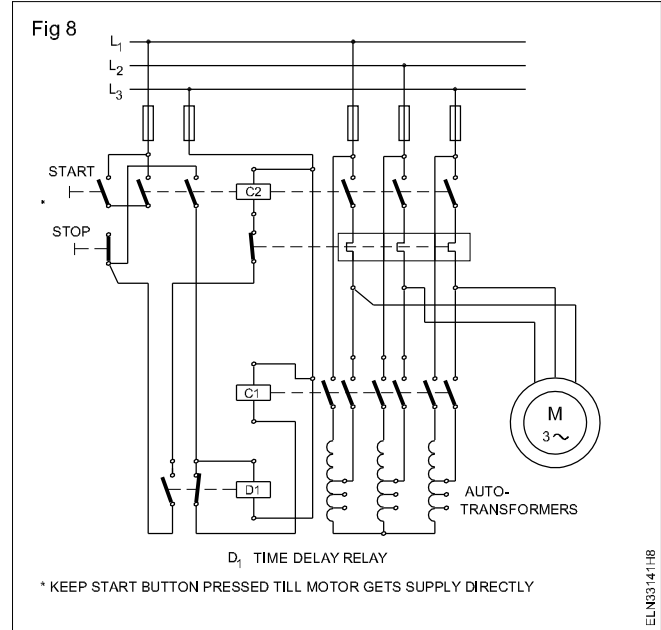
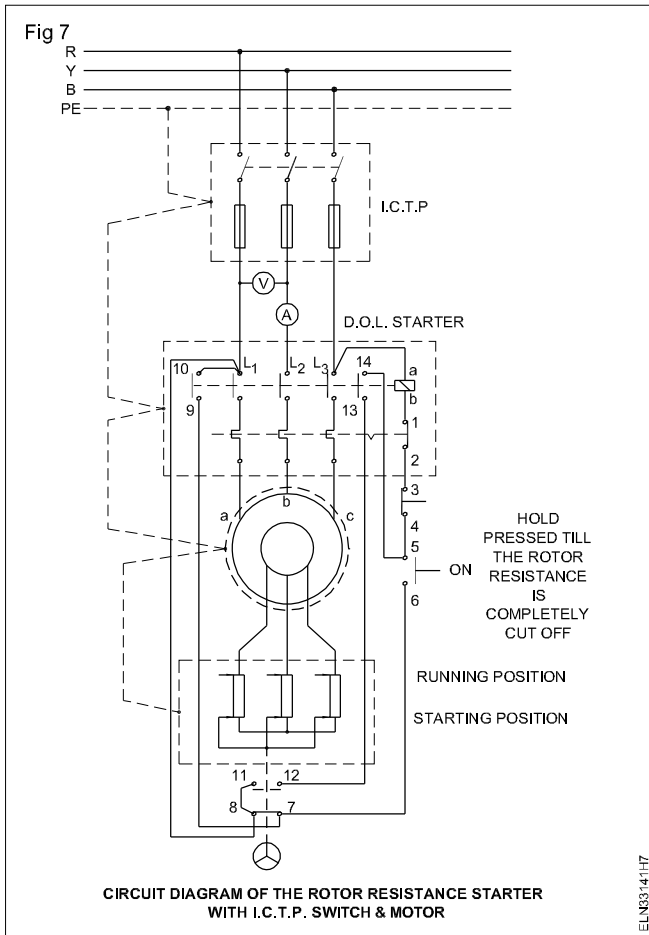

Chart 1

Maintenance of DOL starters

I. Starter check chart

Trouble	Cause	Remedy
1 Contacts chatter	Low voltage, coil is not picking up properly, Broken pole shading ring. Poor contact between the pole. Faces of the magnet. Poor contact between fixed and movable contacts.	Correct the voltage condition. In case there is persistent low voltage. Replace Clean the pole faces. Clean contacts and adjust, if necessary.
2 Welding or overheating	Low voltage preventing magnet from sealing. Abnormal in rush current. Short circuit in the motor. Foreign matter preventing contacts from closing. Rapid inching.	Correct the voltage condition. In case of persistent low voltage coil. Check excessive load current or use larger contactor. Remove the fault and check to ensure that the fuse rating is correct. Clean contacts with suitable solvent. Install larger device or caution the operation not to operate the inch button too quickly.
3 Short life of contact points	Weak contact pressure	Adjust or replace contact springs.
4 Noisy magnets	Broken shading coil Magnet faces not mating Dirt or rust on magnet faces.	Replace magnet Align or replace magnet assembly. Clean with suitable solvents.

Trouble	Cause	Remedy
5 Failure to pick up	Low voltage Coil open or short circuited. Mechanical obstruction in the moving parts.	Check system voltage, In case persistent low voltage, change to a lower voltage coil. Replace the coil. Clean and check for free movement of contact assembly.
6 Failure of moving mechanism to drop out.	Worn or rusted parts causing binding. Residual magnetism due to lack of air gap in magnet path. Gummy substance on pole faces causing binding.	Check wiring in the NVC coil circuit. Replace parts. Replace worn out magnet parts. or demagnetise the parts. Clean with suitable solvent.
7 Overheating of coil	Over-voltage Short circuited turns in coils caused by mechanical damage of corrosion High ambient temperature Dirt or rust on pole faces increasing the air gap.	Check and correct terminal voltage. Replace coil. Relocate starter in a more suitable area or use a fan. Clean pole faces.
II Overload relays / release		
1 Starter is tripping often.	Incorrect setting of over load relay Sustained overload	Reset properly. Check for faults/ excessive motor currents.
2 Failure to trip (causing motor burn out).	Wrong setting of O.L relay Mechanical binding due to dirt, corrosion etc	Check O.L relay ratings and set a proper relay, Clean or replace. Incorrect control wiring. Check the circuit and correct it.
III Fuses		
1 Constant blowing of fuses	Short circuit or poor insulation winding / wiring	Check the motor and the circuit for insulation resistance.
2 Fuse not blowing under short circuit condition.	Fuse rating too high	Replace with suitable fuse.
3 Fuse blowing off frequently.	Fuse rating too low. Overloading of feeder.	Replace with suitable fuse. Check for over-current, leakage and short circuit.

Identify parts and terminals of different types of single phase AC motors

Objectives: At the end of this exercise you shall be able to

- read and interpret the name plate details of the given single phase AC motors
- identify their parts and write their names
- identify the pairs of two windings of 3 terminals & four terminals of single phase motor
- measure the resistance of each winding by an ohmmeter.

Requirements			
Tools/Instruments			
• Trainee's tool kit	- 1 No.	• Single phase capacitor start induction run motor 1HP,240V,50Hz	- 1 No.
• ohmmeter/ multimeter	- 1 No.	• Universal motor 240V, 50Hz,0.5HP	- 1 No.
Equipments/Machines			
• Induction start induction run motor 1/2 HP, 240V, 50Hz	- 1 No.	• Repulsion motor 240V,50Hz, 0.5HP	- 1 No.
		• Bipolar stepper motor 6W, 6V/1A (Permanent magnet type)	- 1 No.

PROCEDURE

TASK 1 : Identify the parts of single phase induction start motor / split phase motor

1. Read and interpret the name plate details of the single phase induction start induction run motor and note down in Table 1.

Table 1

Name-plate details

Manufacturer, Trade mark	Rated frequency
Type, model or serial number	Rated power
Type of current	Rating class
Function	Insulation class
	Rated currentamp
	Rated speedr.p.m
Rated VoltageVolts	Protection class

- 2 Identify the parts of single phase induction start induction run motor from the real objects or from the exploded view chart. (Fig 1).
- 4 Write the name of the parts of each labelled numbers tag in Table -2.

Table 2

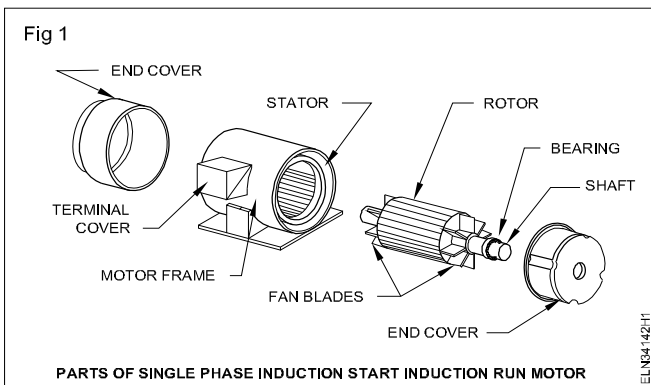

SI No.	Label No.	Name of the parts
1		
2		
3		
4		
5		
6		
7		
8		

- 3 Label the each identified parts with number tags.

TASK 2 : Identify the parts of capacitor start induction run motor

1 Read and interpret the name details of the capacitor start, induction run motor and note down in Table 3.

Table3

Name-plate details

Manufacturer, Trade mark	Rated frequency
Type, model or list number	Rated power
Type of current	Rating class
Function	Insulation class
Fabrication or Serial number	Rated currentamp
Type of connection	Rated speedr.p.m
Rated VoltageVolts	Protection class

2 Identify the parts of the capacitor start, induction run motor from the real objects (or) from the exploded view Fig 2(a), 2(b) & 2 (c) and note down each labelled number in Table 4.

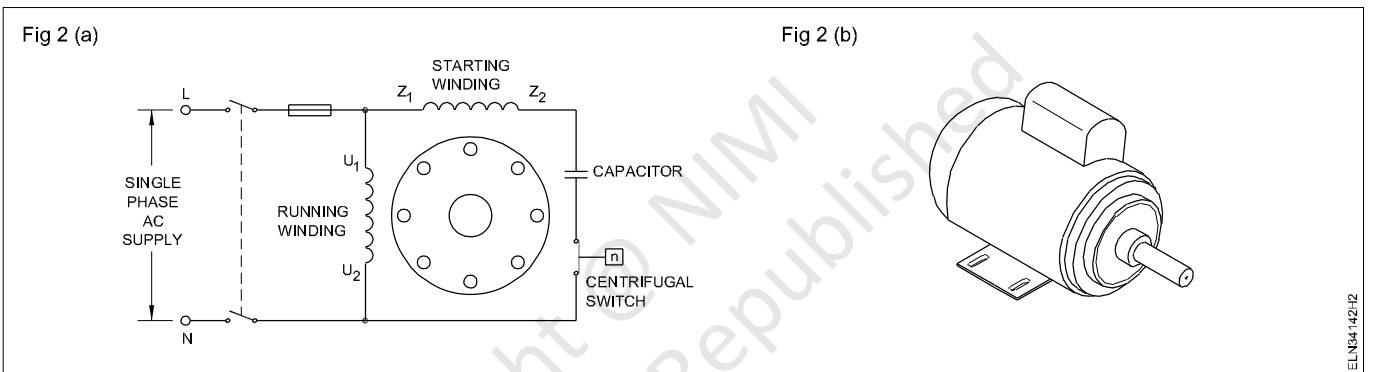
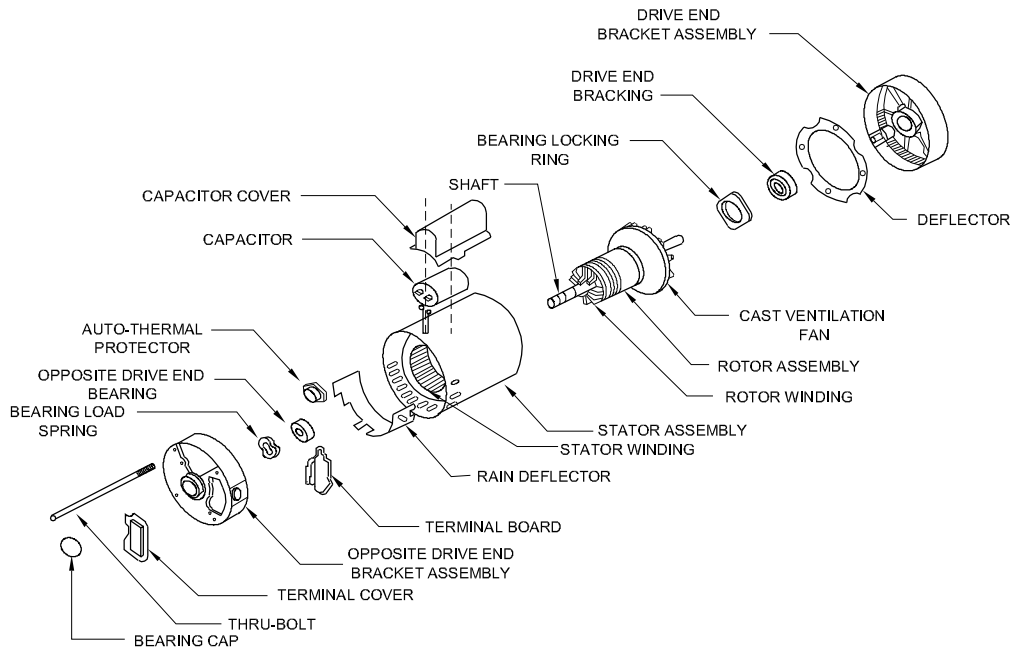

Table 4

SI No.	Label Number	Name of the parts

Fig 2(c)



ELN34142H2(c)

TASK 3 : Identify the parts of single phase capacitor start capacitor run motor/permanent capacitor motor

1 Read and interpret the name plate details of permanent capacitor motor and note down in Table 5.

Table 5
Name-plate details

Manufacturer, Trade mark	Rated frequency
Type, model or list number	Rated powerk.w/HP
Type of current	Rating class
Function	Insulation class
Fabrication or Serial number	Rated currentamps
Type of connection	Rated speedr.p.m
Rated VoltageVolts	Protection class

2 Identify the parts of the permanent capacitor motor from the real objects (or) from the exploded view of Fig 3a and 3b and note down each labelled number in Table 6.

Fig 3a

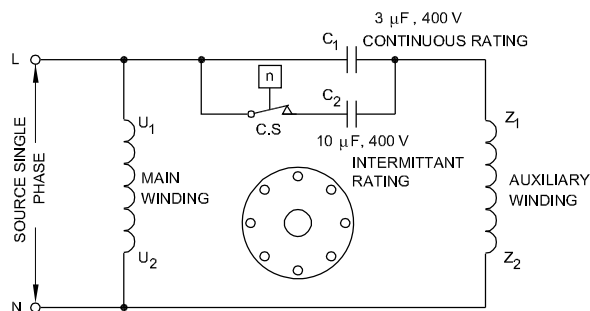

SCHEMATIC DIAGRAM OF A CAPACITOR-START CAPACITOR-RUN MOTOR

Fig 3b

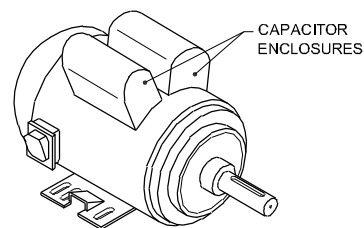

CAPACITOR-START CAPACITOR-RUN MOTOR

ELN34142H3

Table 6

SI No.	Label No.	Name of the parts
1		
2		
3		
4		
5		
6		
7		

3 Get it checked with your instructor.

TASK 4 : Identify the parts of universal motor

1 Read and interpret the name plate details of the universal motor and note down in Table 7.

Table 7

Name-plate details

Manufacturer, Trade mark	Rated frequency
Type, model or list number	Rated powerk.w/HP
Type of current	Rating class
Function	Insulation class
Fabrication or Serial number	Rated currentamp
Type of connection	Rated speedr.p.m
Rated VoltageVolts	Protection class

2 Identify the parts of the universal motor from the real objects (or) from the exploded view.(Fig 4)

4 Write the name of the parts of each labelled number tags in Table 8.

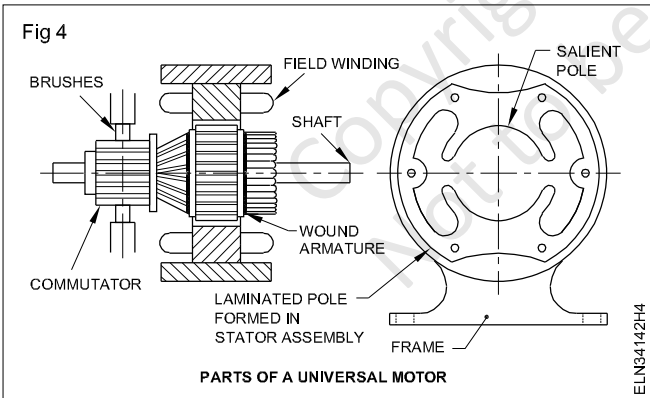

Table 8

SI No.	Label No.	Name of the parts
1		
2		
3		
4		
5		
6		
7		
8		

3 Label the each identified parts with number tags.

5 Get it checked with your instructor.

TASK 5 : Identify the parts of repulsion motor

1 Read and interpret the name plate details of repulsion motor and note down in Table 9.

Table 9

Name-plate details

Manufacturer, Trade mark	Rated frequency
Type, model or list number	Rated powerk.w/HP.
Type of current	Rating class
Function	Insulation class
Fabrication or Serial number	Rated currentamp
Type of connection	Rated speedr.p.m
Rated VoltageVolts	Protection class

2 Identify the parts of the repulsion motor from the real objects (or) from the exploded view (Fig 5) and note down each labelled number in Table 10.

Table 10

SI No.	Label No.	Name of the parts
1		
2		
3		
4		
5		
6		
7		

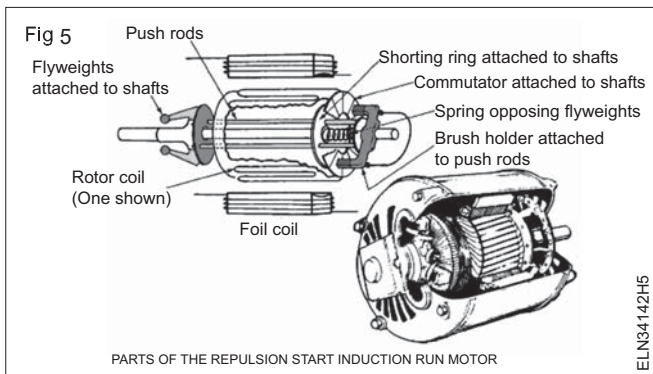

3 Get it checked with your instructor.

TASK 6 : Identify the parts of stepper motor

1 Read and interpret the name plate details of the stepper motor and note down in Table 11.

Table 11

Name-plate details

Manufacturer, Trade mark	Rated frequency
Type, model or list number	Rated powerk.w/HP.
Type of current	Rating class
Function	Insulation class
Fabrication or Serial number	Rated currentamp
Type of connection	Rated speedr.p.m
Rated VoltageVolts	Protection class

2 Identify the parts of the stepper motor from the real objects (or) from the exploded view chart (Fig 6).

3 Label the each identified parts with number tags.

4 Write the name of the parts of each labelled number tags in Table 12.

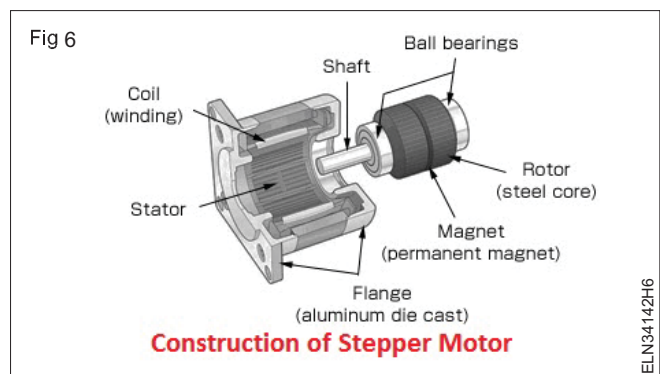

Table 12

SI No.	Label No.	Name of the parts
1		
2		
3		
4		
5		
6		
7		

5 Get it checked with your instructor.

TASK 7 : Identify 3 terminals of the pair of two windings of single-phase split phase induction motor

- 1 Remove the terminal cover. Make connection using a piece of cable and short circuit two terminals at a time to discharge the capacitor.
- 2 Remove the capacitor if any and test the capacitor for insulation and leakage.
- 3 Measure the resistance in between pairs of terminals by an ohmmeter. (Fig 7)
- 4 Mark the terminals between which you get maximum reading as 1 and 3. Mark the unmarked terminal as 2.
- 5 Record the resistance values in Table 13 according to your terminal marking made.

The reading between the pair of terminals 1 & 2 and 1 & 3, whichever is greater is considered as the terminals of starting winding and the other is considered as terminal of running winding.

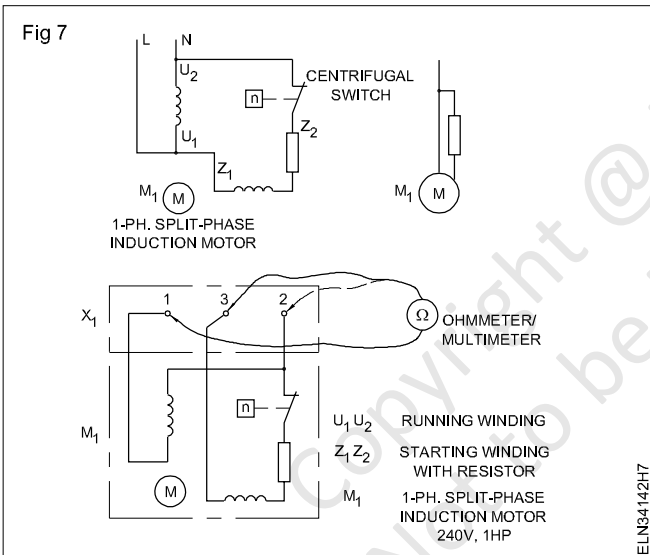

Table 13

Resistance between 1 & 2	Resistance between 2 & 3	Resistance between 1 & 3

TASK 8 : Identify 4 terminals of the pair of two windings of single phase split phase induction motor

- 1 Repeat the steps 1 and 2 of Task 7 , Fig 8.
- 2 Find out the pairs of terminals and number one pair of terminals as 1 and 2. The other pair is numbered as 3 and 4 (Fig 9)
- 3 Measure the resistance between U1 and U2 and Z1 and Z2..

Conclusion

- 1 Higher resistance is between _____ terminals.
- 2 Lower resistance is between the terminals marked as _____

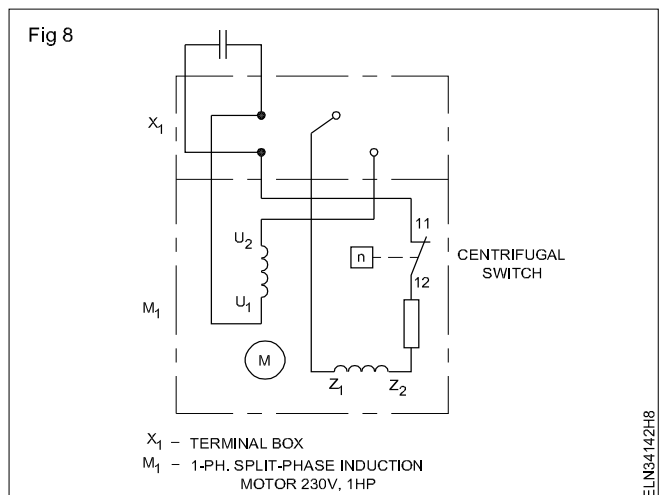

Therefore the starting winding is connected between

Resistance between 1 & 2 = _____ ohms

Resistance between 3 & 4 = _____ ohms

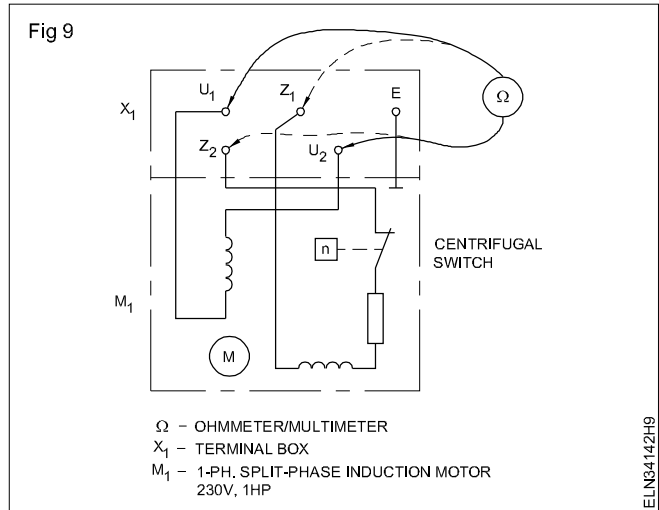

Copyright @ NIMI
Not to be Republished

Install connect and determine performance of single phase AC motor

Objectives: At the end of this exercise you shall be able to

- read the manufacturer’s installation instruction and follow the same
- transfer the template measurements to the mounting base
- make the template of the base (mounting) of the given motor
 - frame (wooden)making
 - marking
 - drilling
 - selecting hole size.

Requirements	
<p>Tools/Instruments</p> <ul style="list-style-type: none"> • Masonry tools like travel spirit level etc- 1 Set • Drilling machine Electric 12.7 mm capacity with drills - 1 No. • Measuring tape 3 meters - 1 No. • Electrician hand tool kit - 1 Set • Spanner set 5 mm to 30 mm - 1 Set • Ball pein hammer 500 g - 1 No. 	<p>Equipments/Machines</p> <ul style="list-style-type: none"> • A.C Single phase motor 0.5 HP 240V - 1 No. <p>Materials</p> <ul style="list-style-type: none"> • Connecting cables - as reqd. • Plywood 8 mm thick 40 x 30 cm - 1 No. • Nuts, grouting bolts - as reqd. • GI wire 14 SWG - 6 m

PROCEDURE

TASK 1: Installation of single phase AC Motors

- 1 Read the name plate details and record in the motor maintenance card (Table 1)

Table 1

Name-plate details

Voltage _____	Phase _____	Type _____
Rating _____	Speed _____	
Power factor _____	Current _____	
SL No. _____		

- 2 Make necessary arrangements at the place where the motor is to be installed as per manufacturer’s nuts and bolts or / and R.C.C. foundation etc.
- 3 Determine the size of the connecting cable and fuse from the rating of the motor. (Table 2)

Fuse current rating will be 3 or 2 times more than running current. If it has the dual function of overload protection also, the rating should be as recommended by the manufacturer or as per I.S recommendations.

- 4 Cut two straight pieces and two cross pieces of plywood as shown in Fig 1 and mark the holes accordingly to the size of the holes of the base of the motor on the wooden frame planks (Fig 1)

Table 2

Calculating fuse ratings of motors

Motor type	Multiply the running current of the motor by
Single phase Squirrel-cage, full voltage start	3
Squirrel-cage, reduced voltage start or high - reactance type (if motor is rated at 30 ampere’s or less)	3

- 5 Select the size of the drill according to the size of the mounting bolt as recommended by the manufacturer.
- 6 Drill the holes according to the size mentioned.
- 7 Make use of the template measurements on the mounting base and get the base mounting ready for installing the motor. (Fig 2)
 - a) Fix the planks with a grouting bolt.
 - b) Check for level using the spirit level.
 - c) Fill the space around the bolts with thin coarse cement mortar.

In the training institute use clay mortar instead of cement to facilitate repetition easily by every trainee in a batch.

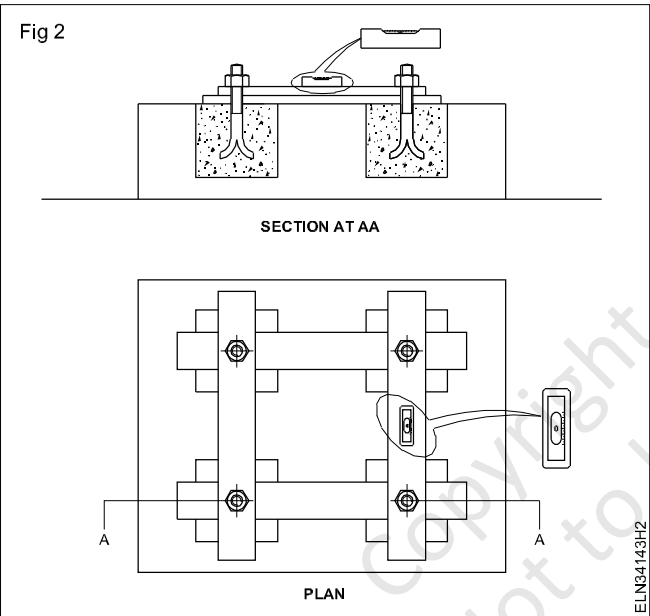
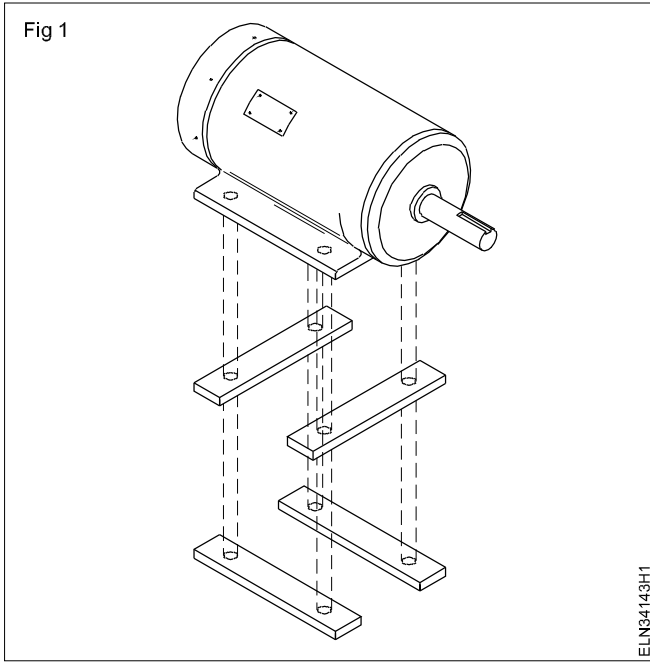

d) Allow it to settle down for 8 to 12 hours, then remove the template planks.

- e) Cure the cement mortar with water for a minimum of 2 days
- f) Finish the surface by plastering neatly.

Include vibration arresting devices as per the manufacturer's instructions such as spring washers etc.

8 Install the motor and fix it with nuts (Fig 3)

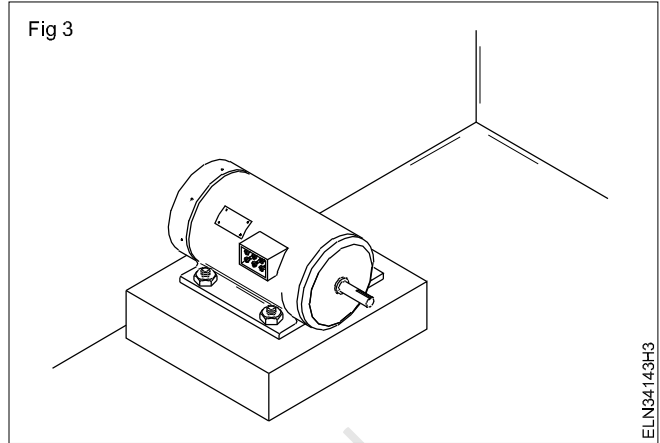

9 Make double earthing in accordance with I.E. regulations and I.S. recommendation.

10 Check the continuity of windings using megger (Fig 4) and also check the effectiveness of grounding. (Fig 5)

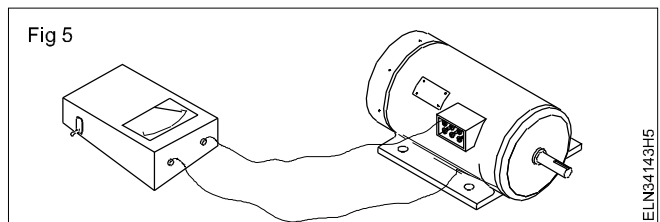
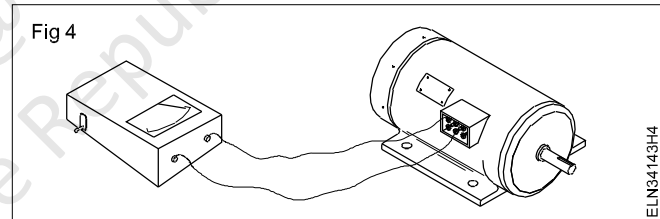

Start run and reverse the direction of rotation of single phase AC motors

Objectives: At the end of this exercise you shall be able to

- start run and reverse the D.O.R of induction start, induction run motors through DOL starter
- start run and reverse the D.O.R of capacitor-start, induction run motors
- start run and reverse the D.O.R of capacitors start, capacitor - run motor
- start, run and reverse the D.O.R of repulsion motor
- start run and reverse the D.O.R of stepper motor.

Requirements

Tools/Instruments

- Trainee's tool kit - 1 No.
- Pulley puller 15 cm - 1 No.
- MI Voltmeter 0-300V - 1 No.
- MI Ammeter 0-10 A - 1 No.
- Megger 500 V - 1 No.
- Ohmmeter - 1 No.

Equipment/Machines

- Single phase induction start, induction run motor 1/2HP, 250V, 50Hz - 1 No.
- D.O.L starter for single-phase motor 10A, 250V - 1 No.
- Capacitor start , induction run motor 250v, 50Hz, 1Hp - 1 No.

- Capacitor start, capacitor run motor 250V, 0.5 HP, 50Hz - 1 No.
- Repulsion motor, 250v 50 hz, 0.25HP available capacity - 1 No.
- Bipolar stepper motor 6w,6v/1A (permanent magnet type) - 1 No.
- Regulated power supply (0.30v) - 1 No.

Materials

- GI wire 14 SWG - 6 m
- 2.5 sq. mm. PVC copper wire 250 V grade - as reqd.
- I.C.D.P. switch 16 A,250V - 1 No.
- Fuse wire 10A - 10 gm

PROCEDURE

TASK 1 : Start , run and reverse the D.O.R of Induction start induction run motor through D.O.L Starter

1 Draw the complete connection diagram of the given motor, starter and I.C.D.P. (Fig 1)

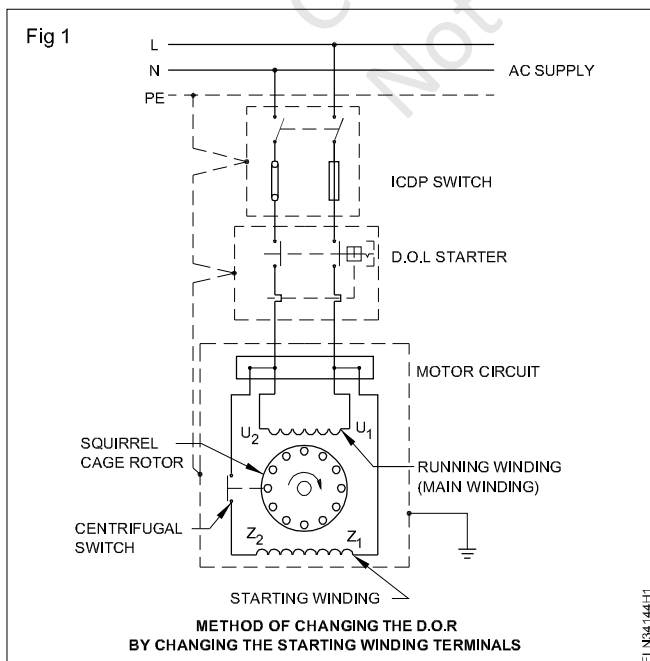

- 2 Get the diagram approved by your instructor.
- 3 Connect the motor through the I.C.D.P. switch and starter as per the approved diagram across the AC rated voltage supply. Provide earth connection to the motor, the starter and the switch.
- 4 Replace with a fuse of proper capacity according to the motor rating and set the overload relay of the D.O.L. starter to the current rating of the motor.
- 5 Switch on the I.C.D.P. switch and press the start-button of the starter.
- 6 Check the direction of rotation and record it below. The direction of rotation is
- 7 Stop the motor by pressing the stop-button; switch `off' the I.C.D.P and remove the fuses.

The I.C.D.P. switch must be switched off and the fuses removed before any modification in the circuit is carried out.

8 Change the connection of the starting winding (Fig 2) and record it below. Direction of rotation is

9 Stop the motor and interchange the connection of the main field winding.

The D.O.R is

10 Stop the motor and switch off the supply.

Conclusion

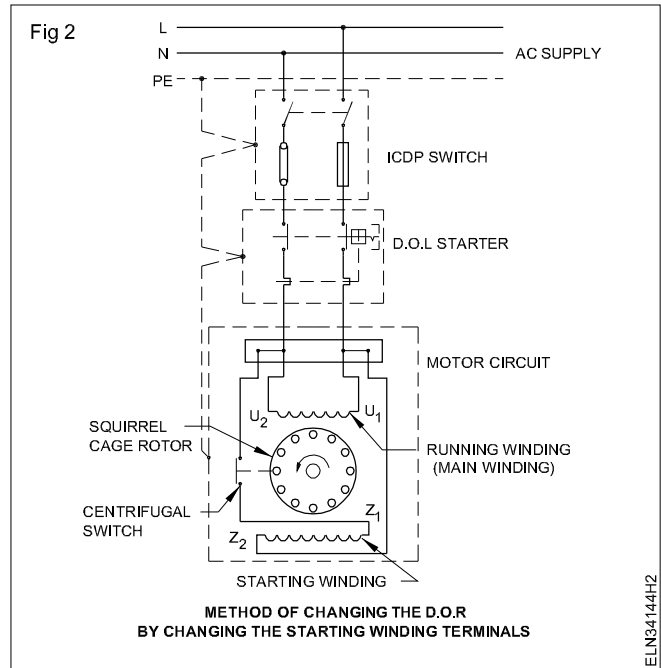

TASK 2 : Start run and reverse the D.O.R of single phase capacitor start induction run motor

1 Make the connection as per the circuit diagram. (Fig 3) Earthing the I.C.D.P. switch, starter and motor is most essential.

2 Provide fuse-wire, according to the rating of the motor, in the I.C.D.P. switch and set the overload relay ampere in the D.O.L. starter to the rated value of the motor.

3 Switch 'ON' the I.C.D.P.

4 Start the motor with the help of the starter and note the starting current, normal running current and the direction of rotation, and enter the details in Table 1.

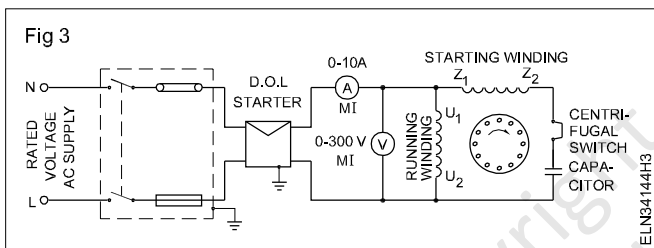

Table 1

Sl.No.	Reference circuit diagram	Starting current	Running current	Direction of rotation
1				
2				
3				

For changing the direction of rotation

5 Stop the motor by the starter and switch 'off' the I.C.D.P., and remove the fuse-carrier.

(Fig 5). Switch 'ON' the motor. Check the effect on the direction of rotation and record the result in Table 2.

6 Interchange either the starting winding or the running winding terminals for changing the direction of rotation. Fig 4 illustrates the changing of the starting winding.

7 Replace the fuse-carrier, and then switch on and start the motor. Note down the direction of rotation in Table 1.

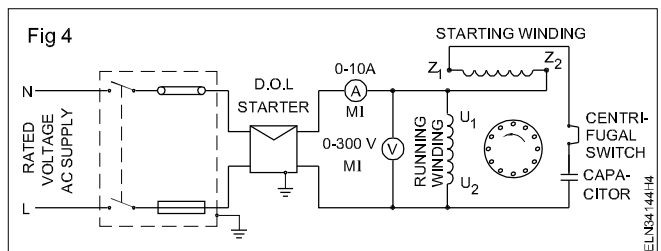

Effect of changing the supply leads

8 Switch off the motor and reconnect the winding. (Fig 3) Interchange the supply terminals as per circuit diagram.

The D.O.R changed / did not change with respect to the condition as per circuit (Fig 3). (Strike out that part of the sentence which is not applicable).

Conclusion

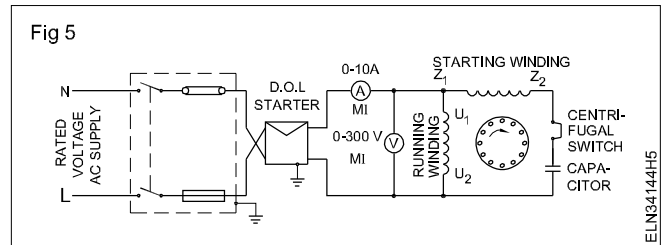

Table 2

SI.No.	Reference circuit diagram	Starting current	Running current	Direction of rotation
1				
2				
3				

TASK 3 : Start, run and reverse the direction of rotation of capacitor start capacitor run motors

- 1 Identify the starting and running condensers and check their condition and data. Enter them in Table 3. Compare and analyse the data also relating to the starting and running condensers.
- 2 Show the readings to your instructor and get his approval.
- 3 Check the condition of the centrifugal switch, and ensure it is working.

Table 3

SI.No.	Component part	Type	Value in micro-farad	Voltage		Duty Cycle	Condition
				Working	maximum		
1	Running capacitor						
2	Starting capacitor						

- 4 Connect the motor to the 240V AC supply through the switch and starter as per the circuit diagram. (Fig 6)
- 5 Insert a suitable size of fuse in the I.C.D.P switch and set the overload relay according to the rating of the motor.
- 6 Get the approval of your instructor for starting. Switch on the I.C.D.P and start the motor by pressing the start- button of the starter.
- 7 Check the direction of rotation and record the D.O.R below. Direction of rotation - clockwise/anticlockwise.

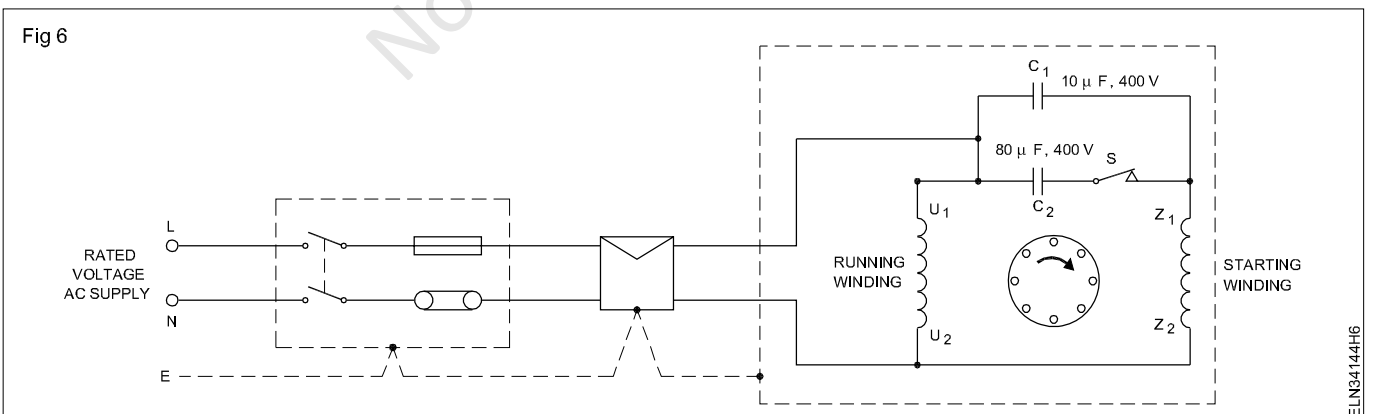

Change the direction of rotation of an AC single -phase capacitor, start capacitor-run motor.

- 8 Stop the motor, switch off the I.C.D.P. Remove the fuse and interchange the running winding terminals. (Fig 7)
- 9 Repeat the steps 6 and 7 of task 3.

Fig 7

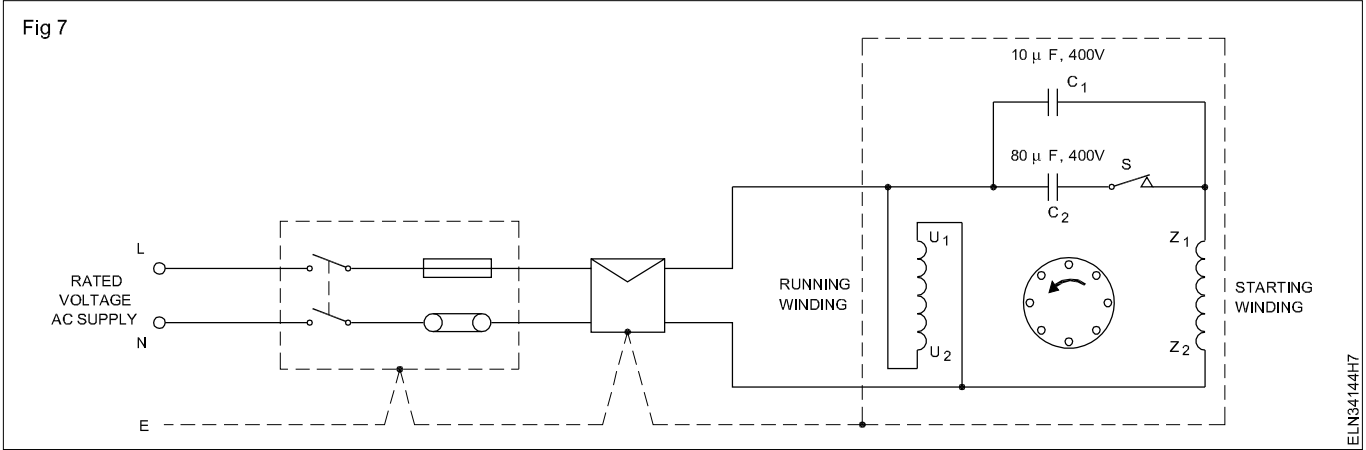

ELN34144H7

The direction of rotation could be changed either by changing the running winding terminal connections or by changing the starting winding terminal connections whichever is easier. The schematic diagram shown in Fig 8 is for a four terminal machine. For a ten terminal machine only the terminal U_1 and U_2 can be changed easily.

10 Stop the motor, interchange the starting winding terminal connections as shown in Fig 8. Keeping the running winding connection as in Fig 6 and repeat the steps 5 to 6 of task 1.

11 Check the D.O.R is clockwise/ anticlockwise.

12 Stop the motor, reconnect the starting and running winding as in Fig 6. Only interchange the supply terminal connections at the starter outgoing side as shown in Fig 9 and repeat the steps 8 and 9 of Task 1.

13 The D.O.R. is clockwise /anticlockwise.

14 Stop the motor. Switch off the ICDP. Remove the fuses. Disconnect the cables. Write your observation regarding the method of changing the direction of rotation and show to your instructor.

Conclusion

Fig 8

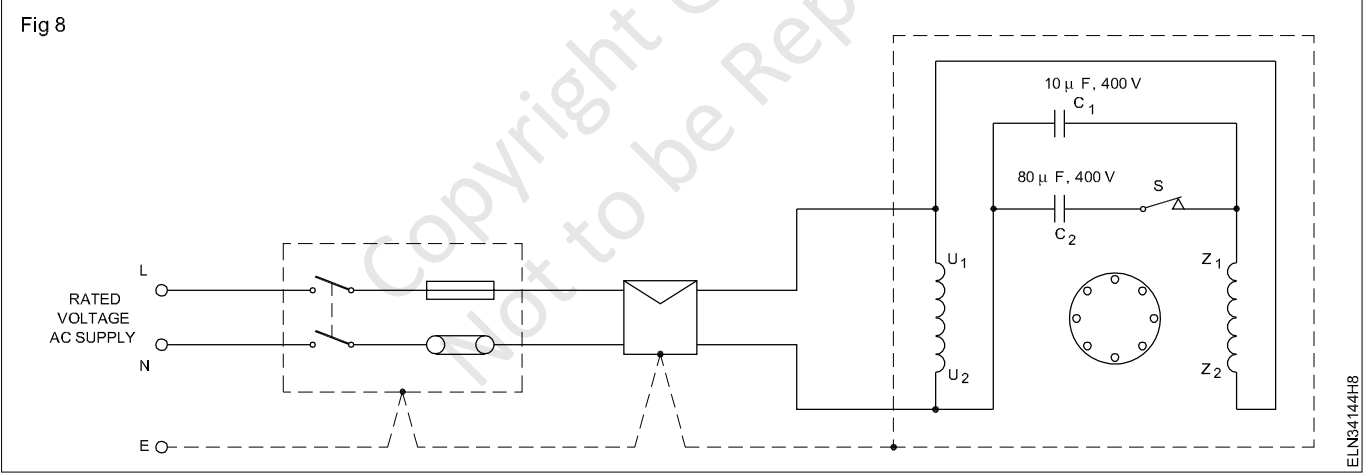

ELN24144H8

Fig 9

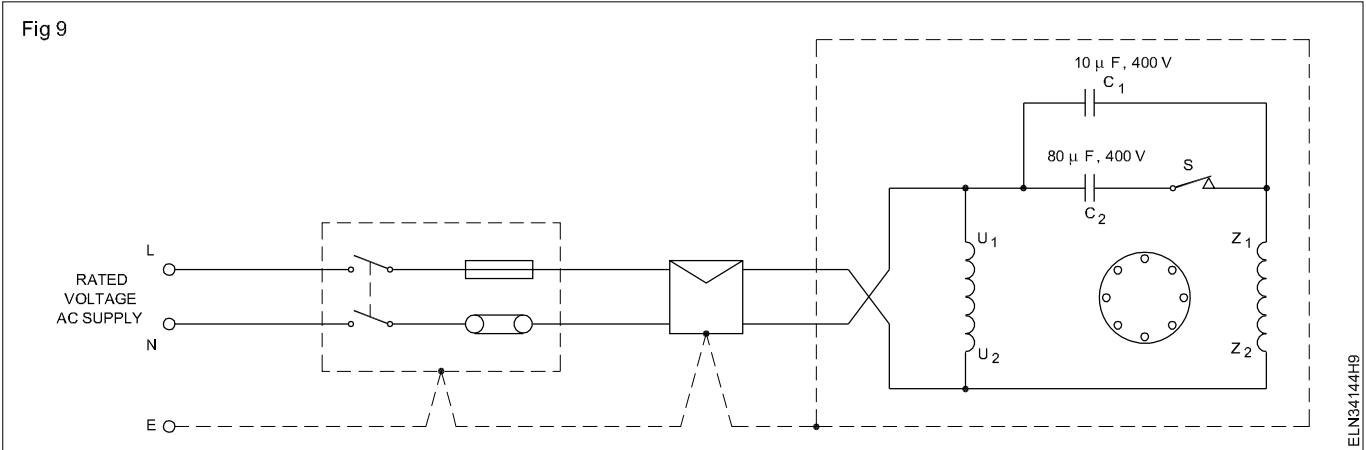

ELN34144H9

TASK 4 : Connect, start, run and reverse the direction of rotation of a repulsion motor

1 Connect the circuit in accordance with the circuit diagram. (Fig 10)

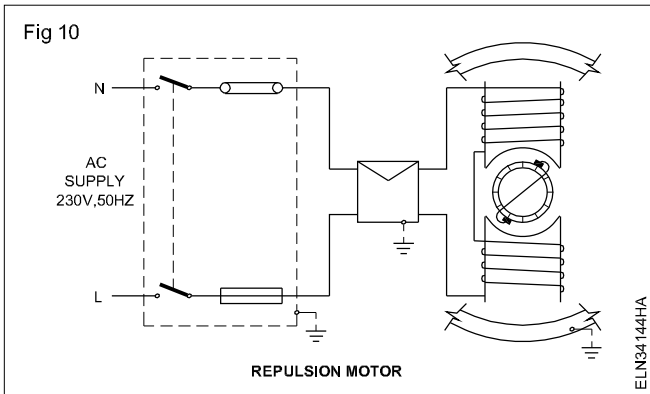

2 Before switching on, keep the brush-rocker handle away from the zero position neutral zone, depending upon the desired direction of rotation.

At the '0' position of the rocker-arm, the motor will not start though the windings are connected to the supply, resulting in heating up of the motor.

3 Switch 'ON' the ICDP and press the 'ON' button of the starter to start the motor. Measure the speed, direction of rotation and enter in Table 4.

4 Slowly shift the rocker arm position away from the earlier position and note down the speed in each step and enter in Table 4.

Table 4

Sl. No.	Rocker-arm position	Speed	Direction of rotation

Normally the rocker-arm position is indicated on a graduated scale.

- 5 Switch 'OFF' the motor. Shift the brush-axis in the opposite direction to the earlier position.
- 6 Switch 'ON' start the motor, observe the direction of rotation and speed, then enter the values in Table 1.
- 7 Shift the rocker-arm position slowly away from the earlier position. Note down the speed at each step and enter in Table 4.
- 8 Switch 'OFF' the supply and disconnect the motor and accessories. Draw your conclusion showing the relationship between brush position, speed and D.O.R.

Conclusion

TASK 5 : Start, run and reverse the stepper motor

1 Connect stepper motor to RPS (Regulated Power Supply) (Fig 11).

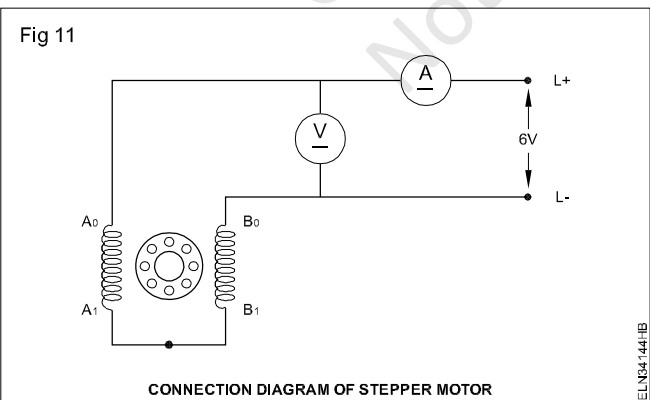

2 Adjust 6V in R.P.S and switch 'ON' the supply and observe the operation of the motor.

3 Note down the current and voltage and direction of rotation.

Current :

Voltage:

N ↑ S - permanent magnet rotating the shaft is called as rotar. A₀ and A₁, B₀ and B₁ are stator.

4 Stop the motor, interchange the supply terminal connections and observe the D.O.R of motor.

Conclusion

Practice on speed control of a single phase AC motors

Objectives: At the end of this exercise you shall be able to

- interpret the name-plate details of an ac series motor and determine full load current
- select a suitable variable resistor
- connect, run and measure the speed for different settings of the resistor.

Requirements			
Tools/Instruments			
• Electrician tool Kit	- 1 No.	• Rotary switch 6A, 250.4 position	- 1 No.
• Voltmeter 0-300 V	- 2 Nos.	Materials	
• Ammeter 0 - 5A	- 1 No.	• Connecting cable	- as reqd.
• Tachometer 3000 rpm	- 1 No.	• ICDP switch 16A 250V	- 1 No.
Equipments/Machines		• Wire wound enamel insulated resistor 10 ohms 100 W	- 2 Nos.
• AC series motor 240V 1/2 HP	- 1 No.		

PROCEDURE

TASK 1 : Connect, run and control speed at a AC single phase motors

- 1 Read the name-plate details and record in Table 1.
- 2 Determine the load current from the name plate

To drop 80 V at position 1 and to drop 40 V at position 2. Calculate the required series resistors R_1 and R_2 and also determine their wattage (see example given)

- 3 Make the connections as per diagram (Fig 1) and make necessary arrangements to load the motor through prony brake.

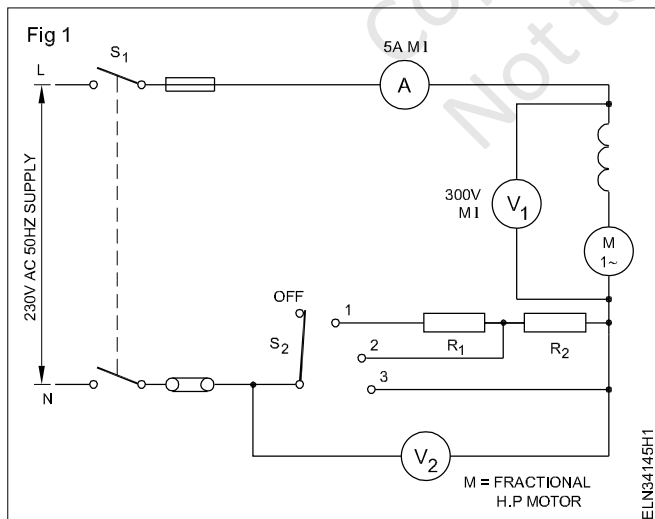

- 4 Close the switch S_1 .
- 5 Set the switch S_2 in position 1 and observe the starting of the motor.
- 6 Measure the current, voltages V_1 & V_2 and the speed. Record the values in Table 2.

- 7 Set the switch S_2 in position 2 and repeat the step 6.
- 8 Set the switch in position 3 and repeat the step 6.

Table 1

Mnufacturer's name	
HP/KW	R.P.M.
Current	Voltage
Type	
Sl.No.	Insulation

Table 1

Switch S_2 Position	Current	V_1	V_2	Speed

- 9 Write the conclusion based on the following questions.

a What is the relation between V_1 and the speed of the motor?

b V_2 is the drop across series resistance. What happens to the speed if it increases when the supply voltage is constant ?

c Can you find some approximate relation between V_2 and fall in speed ?

d Calculate the value of resistance R_1 and R_2 by repeating V_1 & V_2 measurement at the loaded condition of the series motor.

Example

Calculation steps

Motor voltage $V_1 = 175 \text{ V}$

Supply voltage $V = 230 \text{ V}$

Voltage to be dropped $V_2 = V - V_1 = 55 \text{ V}$.

Full load current of motor = $I =$ _____

Resistance value = $R = \frac{V_2}{I} = \frac{55}{I}$

Calculated resistance = _____ ohms.

Nearest standard resistance value is _____

The resistance should carry full load current, $I =$ _____ A.

Therefore resistor selected is _____ ohms _____ amps _____ watts.

Copyright @ NIMI
Not to be Republished

Compare starting and running winding currents of a capacitor run motor at various loads and measure the speed

Objectives: At the end of this exercise you shall be able to

- measure the current in each winding at a given load condition
- load the motor to a specified load.

Requirements			
Tools/Instruments		Materials	
• MI Ammeter 0-5 A type	- 3 Nos.	• Single pole knife switches 16A	- 3 Nos.
• Tachometer 3000 rpm	- 1 No.	• I.C.D.P. Switch 16 A 250V	- 1 No.
Equipment/Machines		• Connecting cable	
• F.H.P. capacitor run motor 240V	- 1 No.		- as reqd.
• Brake load arrangement			

PROCEDURE

TASK 1 : Connect, run and measure starting and running current, speed of AC single phase capacitor run motor

- 1 Identify the terminals of starting winding and running winding.
- 2 Select the ammeter range suitable to the motor under test. Connect the circuit (Fig 1) with brake load arrangement.
- 3 Connect the single pole knife switches S_2 , S_3 and S_4 . (Fig 2)
- 4 Start the motor on no load and open the switch S_2 after the motor attains the rated speed.
- 5 Read and record ammeter readings in Table 1. Measure the speed and record in Table 1.
- 6 Adjust load until A_3 reads 1/2 full load current. Record the currents in each winding in Table 1.
- 7 Repeat the above step for full load.

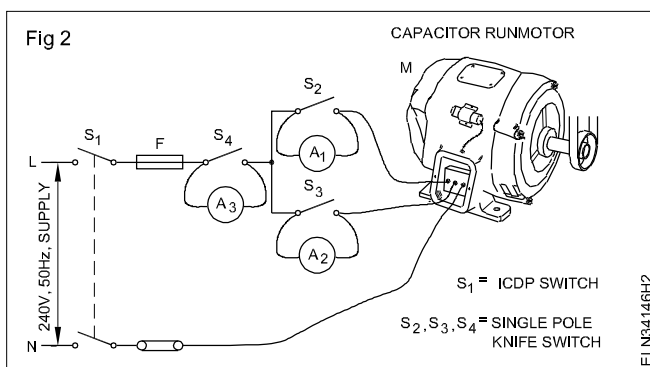
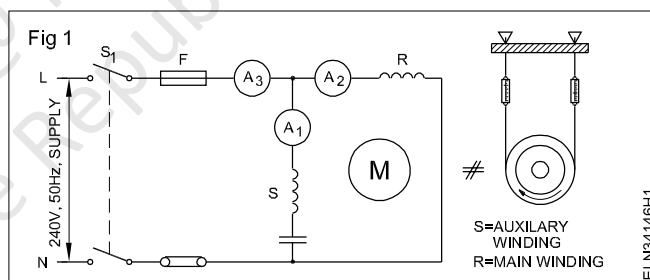

Table 1

Load	Speed	Ammeter reading		
		A_1	A_2	A_3
No load				
Half load				
Full load				

Carry out maintenance service and repair of AC single phase motors

Objectives: At the end of this exercise you shall be able to

- follow general maintenance and service procedure
- test the single phase motor prior to dismantling
- dismantle, identify faults and rectify them
- assemble and test the motor
- identify the general causes of failure and trouble shoot them.

Requirements			
Tools/Instruments		Materials	
• Electrician kit	- 1 No.	• ICDP switch 16A 250V	- 1 No.
• Set of D.E. spanners 8 to 22 mm	- 1 Set	• Test lamp	- 1 No.
• Pulley puller 100 mm and 150 mm	- 1 No.	• Test prods 500V	- 1 Set
	each	• PVC insulated copper cable	
• Nylon hammer 1/4 kg	- 1 No.	2.5 sq mm 250 V grade	- 10 m
• Ohmmeter 0 - 1 kilo ohms	- 1 No.	• Fuse wire 5 amps capacity	- as reqd.
• Industrial, thermometer, metric,		• PVC insulation tape 20 mm size	- as reqd.
0 to 300°	- 1 No.	• Bearing - Grease	- 200 gms.
• Megger 0-500 V	- 1 No.	• Kerosene oil	- 1 litre.
• Voltmeter M.I. type 0-300 V	- 1 No.	• Cotton waste	- 100 gms
• Ammeter M.I. type 0-5 amps	- 1 No.	• Shellac varnish	- 1/4 litre
		• Sandpaper 'O'	- as reqd.
Equipments/Machines			
• Fraction horse power AC			
single phase (split phase) motor	- 1 No.		

PROCEDURE

TASK 1: Perform maintenance and service as per the following procedure

- 1 Read the name-plate details of the motor and record in Table 1.

Table 1

Name-plate details of the motor

Make. _____	Frame _____	No. _____	Model _____
Type _____	HP _____	Volts _____	
Amperes _____	Phase _____	Cycles _____	

- 2 Switch 'OFF' the respective I.C.D.P. main switch.
 - 3 Remove the fuses and keep in safe custody.
- Remove the sub-circuit fuses which supplies power to the ICDP.**
- 4 Clean the main switch with a brush.
 - 5 Check the incoming and outgoing leads of the I.C.D.P. main switch for discolouring.

Discolouring normally indicates loose terminal connection.

- 6 Check the cable terminal connection screws and tighten them with the help of a screw driver.
- 7 Open the starter cover and clean the parts with a brush.
- 8 Check the leads and the terminal screws. Tighten the screws, if found loose.
- 9 Check the overload setting and if necessary, set it to the rated current of the motor.
- 10 Check the contact points of the starter for pittings.

If the contact points are lightly pitted, use a sandpaper to clean them. Badly pitted or damaged contacts need to be replaced.

- 11 Clean the external surface of the single phase motor using brush, a piece of the cloth and a blower.
- 12 Open the terminal cover.
- 13 Note the incoming, starting winding, running winding, capacitor and centrifugal switch connections and draw a diagram in your record. Indicate the colour of cables in the diagram.

Normally some letter markings are found in the terminal plate. Some manufacturers give the schematic diagram on the back side of the cover. In case no diagram or marking were there wire clearly the colour of the cables connected to the terminal plate. Fig 1 is the schematic diagram of a particular single phase motor and Fig 2 shows the terminal connections with the simplified internal connections. These diagrams are given for your guidance. Draw the required diagrams to show the connections of the motor for which maintenance is required.

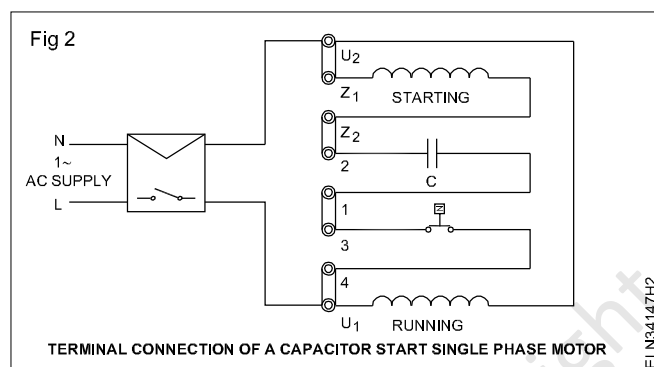
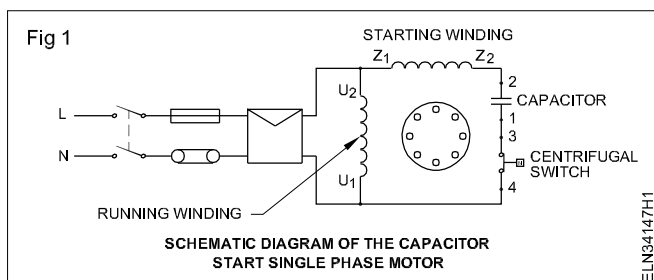

- 14 Open the shorting loops and incoming connections.
- 15 Check the continuity a) main winding b) starting winding c) centrifugal switch.
- 16 Record the finding in Table 2
- 17 Measure the resistance value of the windings and contact resistance value of the centrifugal switch with an ohmmeter and record it in Table 2.
- 18 Check the capacitor and the centrifugal switch for its condition with an ohmmeter and enter the result in Table 3.

A capacitor when tested with a Megger or multimeter, the meter needle will show short indicating the capacitor is charged. When the capacitor terminals are shorted by a cable, a spark will be noticed indicating the capacitor is discharged and in good condition. However whether the capacity is charged or the capacitor able to hold the charge for a specified time cannot be checked by this test.

- 19 Check the insulation value of the windings with the help of a Megger and enter the result in Table 4.
- 20 Dismantle the motor following the procedural steps.
- 21 Clean the stator and rotor with a brush and blower.
- 22 Clean the bearings and grease cups with kerosene and check the bearing.
- 23 Identify the bearing which is found worn out replace it with a similar type.
- 24 Check the internal connections and lead insulations.

If necessary reinsulate the leads.

- 25 Check the rotor bars.

If any loose bar is found, it has to be brazed.

- 26 Check the rotor and stator surface for rubbing marks.

Rubbing marks indicate either worn out bearing or wrong alignment in assembly. Correct them.

- 27 Check the centrifugal switch for its tension and perfect contact between the points of contact.

If the switch is in a bad shape it should be replaced with a similar switch. Dressing of contact could be done with the help of sandpaper.

- 28 Identify the insulation resistance value measured earlier. If found to be less than 1 megohm, dry the winding in an oven or with incandescent lamps and varnish it.
- 29 Assemble the motor following procedural steps.
- 30 Perform the earlier test and enter the results in Tables 2 and 4.

The test result should not vary too much. Rather it should show improvement. Discuss with your instructor regarding the test results.

- 31 Connect the shorting loops and incoming leads as per your diagram.
- 32 Replace the fuses of correct value in the fuse grip and replace the carrier in the holder of the I.C.D.P. mains.
- 33 Check the earth connections to the motor starter and switch correct them if necessary.
- 34 Start the motor and test run for about 30 minutes.
- 35 Check the frame temperature of the motor and satisfy yourself that the temperature is within the reasonable limits.
- 36 Check for any undue noise or vibrations.
- 37 Stop the motor and write your observations in the maintenance card.

If any undue noise or vibrations is found stop the motor and recheck the tightness of the end plate bolts and frame bolts.

Table2

Sl.No.	Description	Continuity check		Resistance value		Remarks
		Before dismantling	After assembling	Before dismantling	After assembling	
1	Main winding					
2	Starting winding					
3	Centrifugal switch					

Table3

Sl.No.	Description	Condition
1	Capacitor	
2	Centrifugal switch	

Table4

Sl.No.	Description of the test	Test result in megohms		Remarks
		Before dismantling	After assembling	
1	Between main winding and starting windings (auxiliary)			
2	Between main winding and the body/frame			
3	Between starting winding and the body/frame			
4	Between centrifugal switch and the body/frame			
5	Between centrifugal switch and the winding (both the windings shorted)			

TASK 2 : Trouble shooting procedure

- 1 Follow the troubleshooting charts No.1 to 5 to identify the symptom and rectify the fault. (Refer trade theory)
-

Practice on single /double layer and concentric winding for AC motors, testing and assembling

Objectives: At the end of this exercise you shall be able to

- record the name plate details of the given single phase having single layer/double layer concentric type winding
- dismantle the motor
- collect the winding data
- draw the connection and developed diagrams
- strip the winding and clean the slots
- prepare the slot liners and insulate the slots
- prepare the stepped former and wind the concentric group of coils
- lay the coil groups in the stator slots
- connect the coil groups and phase leads
- shape the overhang
- test the winding
- varnish the motor
- test and run the newly wound motor.

Requirements			
Tools/Instruments		Equipment/Machines	
• Electrician tool kit	- 1 Set.	• AC split phase motor FHP 250V	- 1 No.
• Scissors 250mm	- 1 No.	Materials	
• Nylon hammer 80 mm dia, 120mm long head	- 1 No.	• Super-enamelled copper wire	- as reqd.
• Soldering iron 125W, 240V	- 1 No.	• Millinex (or triplex paper) 10 Milli	- as reqd.
• Scale and weight 1 to 450 gms	- 1 Set.	• Empire sleeve 1 mm, 2mm, 3mm, 4mm & 5mm	-1m.each
• Cold Chisel 100mm dia, 200mm long	- 1 No.	• Cotton tape 20mm roll of 25 m	-1 Roll
• Multimeter	- 1 No.	• Bamboo wedge	- as reqd.
• Centre punch 100mm	- 1 No.	• Resion Core solder 60:40	- as reqd.
• Steel rule 300mm	- 1 No.	• Varnish (air dry)	- as reqd.
• Wood rasp file, half round 200mm	- 1 No.	• Brush 25 mm	- 1 No.
• Tray 200mm x 200mm x 50mm	- 1 No.	• Fibre sheet	- as reqd.
• Megger 500 V	- 1 No.	• PVC insulated copper wire 21/0.2 mm	- 3 m
• DE spanner 5 to 22 mm	- 1 Set		
• Outside Micro meter 0 - 25 mm	- 1 No.		

PROCEDURE

TASK 1: Rewind a single phase split phase motor (concentric coil winding)

Collection of data

- 1 Collect and record the machine data in Table 1.
- 2 Remove the pulley by using a pulley puller. Remove the fan cover and then remove the cooling fan blade assembly.

- 3 Mark both the end covers with distinguished markings with a centre punch, and correspondingly mark the body also.

Table 1

Name-plate details

Manufacturer's Name	Serial Number.....
Output.....KW/HP.	VoltageV CurrentAmps
FrequencyHz	Speed r.p.m. Cycle
Insulation	Frame No.Startingcapacitor Mfd

Table 2

Winding data

1 Terminal marking with colour of the lead cables					
2 Connection end of the winding with respect to the terminal box					
3 No. of slots		No. of poles		Type of winding	
4 Wedge material		size		Binding material	
5 Overhang dimension		Non-connection end		Connection end	
Outer dia.	 mm	 mm	
Inner dia.	 mm	 mm	
Length from core	 mm	 mm	
6 Slot insulation materials		1		Size thickness	
		2		Size thickness	
7. Type of winding		Kind of wire end		No. of coils	
1 Running		
2 Starting		
8 Shaft side rotation		CW/ACW			
9 Coil size from outer coil		Starting winding		Running winding	
		Lengthmm		Lengthmm	
		Breadthmm		Breadthmm	
10 Weight of running coils (Total)	 kg			
11 Weight of starting coils (Total)	 kg			
12 Lead wire : Type	 Size			
		Front bearing No.			
		Rear bearing No.			
13 Core length					
14 Coil group connection diagram					
15 Any other information					
<i>Example:</i> Single phase capacitor motor					
No. of poles - 4					
No. of slots - 24					
No. of coils - 20 (12 for main and 8 for starting winding).					

- 4 Mark and remove the connection leads from the terminal box. Enter the details in Table 2.
- 5 Loosen the screw bolt/tie rod on both the end shield covers, and also remove the centrifugal switch connections.

- 6 Remove the rotor from the stator.
- 7 Inspect the rotor for any defect, and the bearing for its condition.

If any of the rotor bar is open correct the defect by brazing. If bearing is worn out replace it with a new one.

- 8 Take the possible data before removing the coil and record it in Table 2.
- 9 Mark the stator for indicating connection lead side with respect to the terminal box. Enter the details in Table 2.
- 10 Apply a thinner in the connection lead side to loosen the varnish and locate the end connection. Draw the group connection diagram and also prepare the developed diagram in a separate sheet of paper and attach with these sheets.

To avoid imaginary terms while writing the procedure, an example for a single phase capacitor motor having concentric coil winding is given below.

Certain procedural steps are specifically written for the motor given in this example. However, you have to follow the data taken strictly from the given motor, to get the required performance.

Information from collected data

- Coil pitches - Main winding 5,3,1
Starting winding 5,3
- Coil throw - Main winding 1-6,2-5,3-4
Starting winding 1-6, 2-5

This is the whole coil connection as the end of the 1st coil is connected to the end of the 2nd coil and the starting of the 2nd coil is connected to the starting of 3rd coil etc.

For your guidance, the group connection diagram is given in Fig 1 and the developed diagram is given in Fig 2.

- 11 Measure the overhang at both sides of the winding. Record it in Table 2 and prepare the template.
- 12 Collect the possible data like, number of slots, coil pitch etc. and record in Table 2.

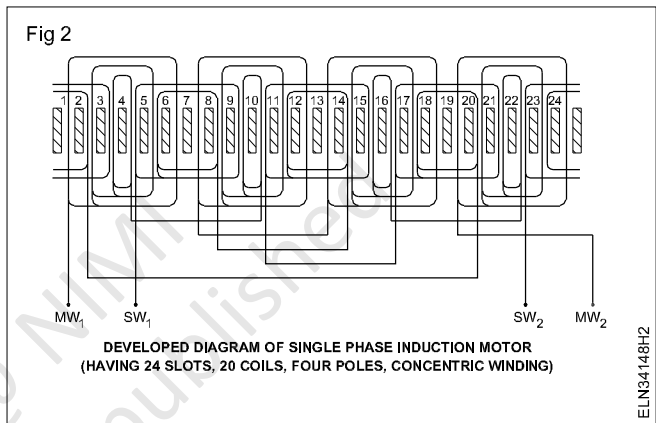
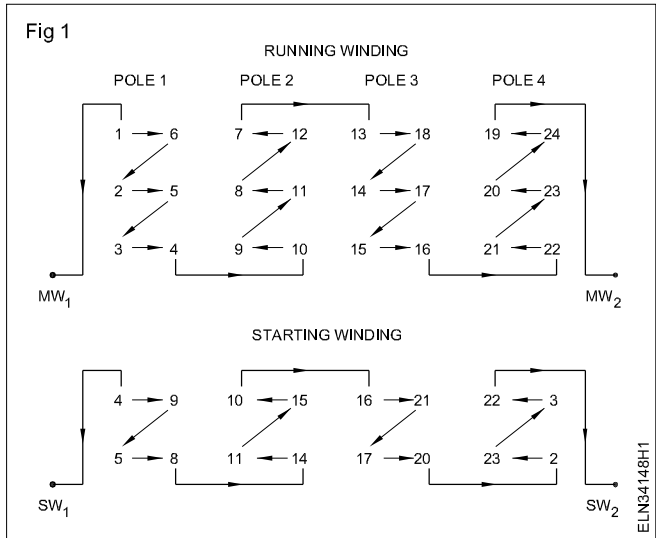

- 13 Cut the coils except one set of coils each in the starting and main winding with the help of a cold chisel at the non-connection end (i.e. normally load side).
- 14 Strip the old winding from the stator slot. If it is hard use a blowlamp to heat the winding and pull out the coils.
- 15 Remove the left out coils in their original shape.

Use a thinner to loosen the coils. Once a thinner is used never use the blowlamp as the coils will catch fire.

- 16 Measure the size of the wire, size of the coil and collect other details as required and record them in Table 2.

TASK 2 : Rewind the motor

- 1 Set the core if it is mangled and clean the slots.
- 2 Select the insulation paper of the same grade and thickness or equivalent as in the original and prepare the insulation paper to have the same shape and size as in the original insulation.
- 3 Insulate the slot with the prepared insulation paper.
- 4 Make a former or select a readymade former according to the size of the original set of coils.

- 5 Select the correct size of winding wire as in the original and wind the coil in the former taking care to maintain the same number of turns.
- 6 Make the required number of main and starting winding coils.

The running winding should be placed at the bottom of the slot. Then the starting winding should be placed at the top of them as per data taken.

- 7 Insert the newly wound main winding coils into the stator slots, placing the winding in the same position as in the original.

While placing the coil take care to insert the turns in small bunches without forcing them too much. The winding wire should not rub the core. Avoid this by placing a leatheroid paper between the coils and the core.

- 8 Wedge the slots permanently which are having single coil side only. Temporary wedges may be used in the other slots.
- 9 Shape the coil with a nylon hammer at both sides. After placing all the main winding coils,
- 10 Check individual groups of the main winding for continuity and insulation resistance.
- 11 Verify the test results of the main winding are found correct, then place the starting winding in the designated slots as per the group connection and developed diagram.
- 12 Identify wherever, the slot contains two coil sides, (according to the example given, all the slots except slot 1,6,7,12,13,18,19 and 24) soon after inserting the bottom coil side, place the separator insulation paper over it..

After the top coil side is inserted, fold the slot liners, place the separator and wedge the slots.

- 13 Provide a phase separator between the running and starting winding coils in the overhang.
- 14 Shape both the sides of the overhang as in the original with the help of a mallet/nylon hammer.

Apply uniform mild blows. Avoid damage to the wires or insulation.

- 15 Insert proper empire/PVC sleeves in the winding ends and connect all the coil ends and lead cables according to the connection diagram drawn earlier.
- 16 Check the connection once again by comparing the group connection and developed diagram.
- 17 Solder the end connections and put the sleeves in position.
- 18 Set the overhang sides so as to have a uniform thickness and bind the thread/tape similar to the one in original.

Use the templates and check the dimensions of the overhang at intervals to see the overhang has attained a shape as in the original winding. Make sure that the overhang does not touch the body or the end cover.

TASK 3 : Test the winding

- 1 Check the winding for short circuit, open circuit and insulation resistance by a multimeter and Megger respectively.
- 2 Check the condition of the capacitor and centrifugal switch. If there is any fault replace them by new ones.
- 3 Connect the lead connections, capacitor and centrifugal switch according to the connection diagram and terminate them in the terminal box.
- 4 Assemble the motor and then run the motor for 15 minutes.
- 5 Observe the direction of rotation. If necessary change the connections.
- 6 If test is OK then dismantle the motor.
- 7 Preheat the stator and impregnate the winding with varnish.
- 8 Remove the excess varnish in the face of the stator slots after drying.
- 9 Reassemble the motor and test it on load for 8 hours.

Connect, start, run and reverse the direction of rotation of universal motor

Objectives: At the end of this exercise you shall be able to

- connect a universal motor to the supply through a D.O.L. starter and start the motor
- reverse the direction of rotation of a universal motor.

Requirements	
<p>Tools/Instruments</p> <ul style="list-style-type: none"> • Insulated cutting pliers 150 mm - 1 No. • Screwdriver 150 mm - 1 No. • D.E. spanner set 5mm to 20 mm - 1 Set • Megger 500 V - 1 No.. • Test lamp 100W/240V - 1 No. • Ohmmeter/multimeter - 1 No. • Tachometer 1500-15000 r.p.m. - 1 No. 	<p>Equipments/Machines</p> <ul style="list-style-type: none"> • Universal motor 250V, 50 Hz, 0.5 HP - 1 No. <p>Materials</p> <ul style="list-style-type: none"> • 2.5 mm multi-strand PVC copper cable - 10 mts. • Bare copper wire 14 SWG - 05 mts. • 250 V 16A, I.C.D.P. switch - 1 No. • D.O.L. starter 250V suitable for 0.5 HP single phase motor - 1 No.

PROCEDURE

- 1 Arrange and adjust a suitable load for the given universal motor.

A universal motor has high starting torque. Without load, the motor reaches a dangerously high speed resulting in damage. Normally do not arrange loading through the flat belts which may slip during running. Arrange direct drives or 'V' belt drives as load.

- 2 Select the proper rating of I.C.D.P. switch, cables, fuse and starter, according to the rating of the given universal motor.
- 3 Open the starter cover, trace out the connection and set the overload relay to the motor current rating.

- 4 Connect the motor as per circuit diagram (Fig 1) with proper frame earth connections.

Check for the correct load arrangement before starting the motor.

- 5 Switch on the I.C.D.P. and push the 'ON' button of the starter.
- 6 Observe the D.O.R. and record it below.
The D.O.R. is _____
- 7 Measure the speed with a tachometer and record it below. The speed is _____ r.p.m.

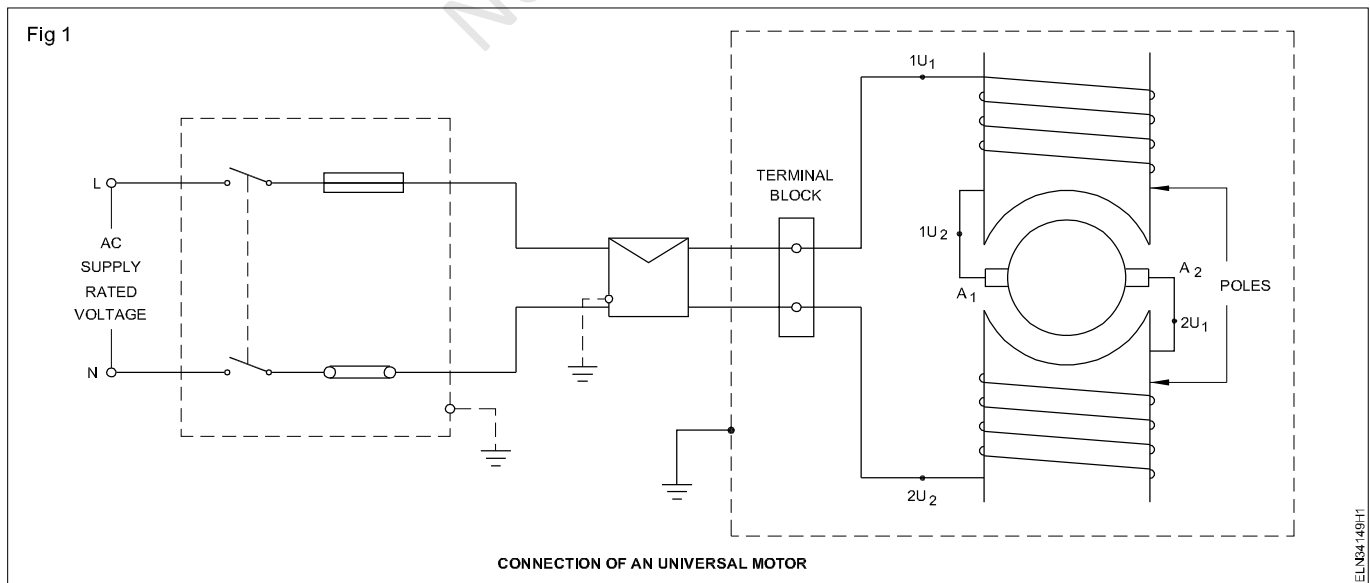
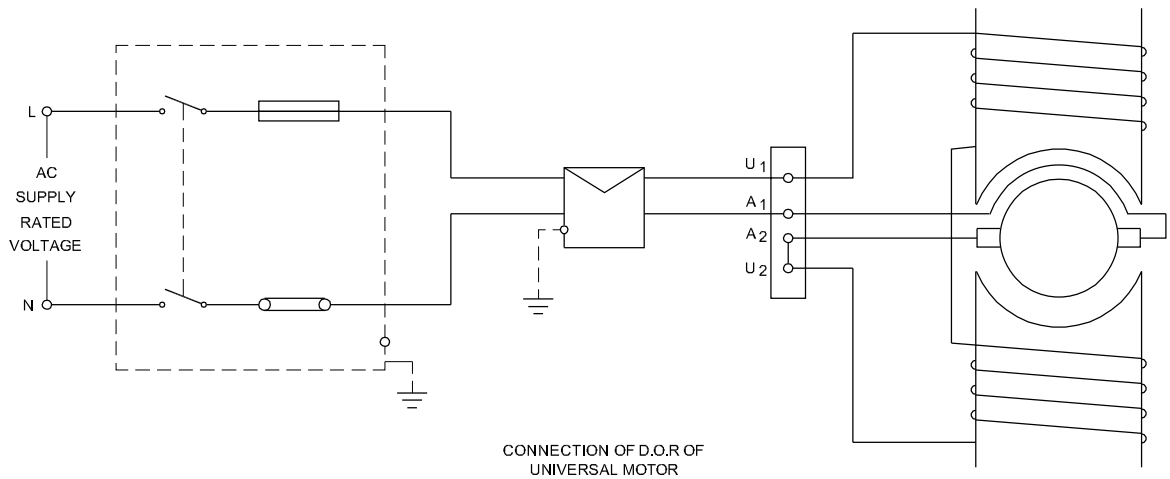

Fig 2



ELN34149H2

The speed of a universal motor depends upon the load. While setting the range of the tachometer, first set at a high range and then step down the range to a suitable measurable value.

In case reversing the direction of rotation of the motor is necessary, change either field or armature terminals. While changing the armature terminals of compensated universal motor, change the compensating winding terminals also.

- 8 Stop the motor by the stop-button of the starter. Switch off the I.C.D.P. and remove the fuse.

- 9 Discuss with your instructor the possibility of alternate connections to the one. (Fig 2)

Change the direction of rotation

Generally the D.O.R of the universal motor is designed in one direction by the manufacturer. Changing the direction of rotation in such cases will result in high sparking, increased heating and failure of the machine.

- 10 Change either the field or the armature terminals.
- 11 Follow the procedural steps 5 to 8 and record the direction of rotation and speed in the space given below:

The D.O.R. is _____

The speed is _____

Copyright © NIMI
Not to be Reproduced

Carry out maintenance and servicing of universal motor

Objectives: At the end of this exercise you shall be able to

- read and interpret the name-plate details of the motor
- inspect and ascertain the conditions of the motor
- dismantle the universal motor
- test and rectify the faults
- assemble and test the universal motor
- troubleshoot the universal motor.

Requirements			
Tools/Instruments		Materials	
• Electrician tool kit	- 1 Set	• Test lamp 60W 250V	- 1 No.
• Philips screwdriver 200mm	- 1 No.	• Cotton waste	- as reqd.
• Cold chisel 200 mm	- 1 No.	• Bearing grease quality and quantity	- as reqd.
• Spanner set double ended set of 8 Nos. 6mm to 25 mm	- 1 Set	• Sandpaper smooth sheet of 300 mm square	- as reqd.
• Mallet (wooden) 7.5 cm dia	- 1 No.	• Kerosene oil	- 1/2 litre.
• Bearing puller	- 1 No.	• Empire cloth 1 mm	- as reqd.
• Megger 500 V	- 1 No.	• Carbon tetrachloride	- as reqd.
• Ohmmeter 0 to 1 kilo ohm	- 1 No.	• Empire sleeves 3 mm to 6 mm	- as reqd.
• External and internal growler	- 1 Set	• Carbon brushes of suitable grade and size	- 2 Nos.
Equipments/Machines		• Lead and tin solder (Resin cored)	-20 grams.
• Universal motor as available	- 1 No.		

PROCEDURE

TASK 1 : General maintenance and servicing procedure

- 1 Note the name-plate details of the motor and enter in complaint card shown in Table 1.

Table 1

Complaint card

Customer _____	Date _____	Job No. _____	Make _____
Frame No. _____	Model _____	Type _____	HP _____
Volts _____ Ampere _____ Phase _____ Cycles _____			
Serial No. _____			
Suggestion/Complaint : _____			
Signature of Section in-charge _____			

- 2 Inspect the motor visually and record the defects in Table 2.
- 3 Read the complaint card and ascertain the area of trouble.
- 4 Conduct, continuity, open circuit and insulation resistance tests and enter the values in Table 3.

Table 2

Results of visual inspection

Sl.No.	Description of visual inspection	Result of visual inspection

- 5 Mark the exact position of the end plates with yoke.
- 6 Dismantle the machine.
- 7 Clean the internal parts of the motor.
- 8 Check the following.
 - a) Test the shorting between commutator segments. (Fig 1)
 - b) Clean the commutator with carbon tetra chloride.
 - c) Check the mica insulation; if found raised beyond the commutator surface undercut the mica.(Fig 2)

Table 3
Test results

Sl. No.	Description	Continuity Test		Insulation resistance		Resistance Test		Remarks
		Before Dismantling	After Assembling	Before Dismantling	After Assembling	Before Dismantling	After Assembling	
1	Field winding							
2	Armature winding							

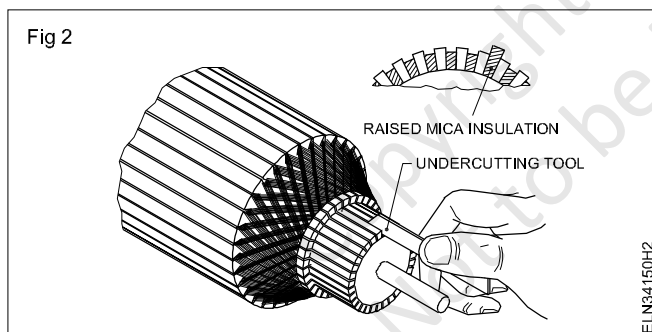
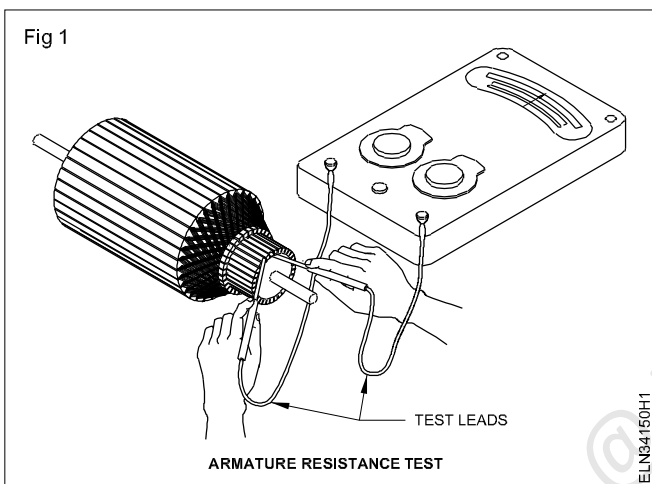

- d) Check the commutator surface for pittings. If necessary use sandpaper to remove the pittings.
- e) Check for overheated spot at raiser and resolder the wires if necessary.
- f) Check the length of brushes. If found short, replace them with the same grade of correct size brushes.
- g) Check the brushes for proper bedding. If necessary bed the brushes. Refer Fig 3.

Insert the new brush and shape the end to the curve of the commutator using glass paper wrapped around the commutator and light pressure on the brush.

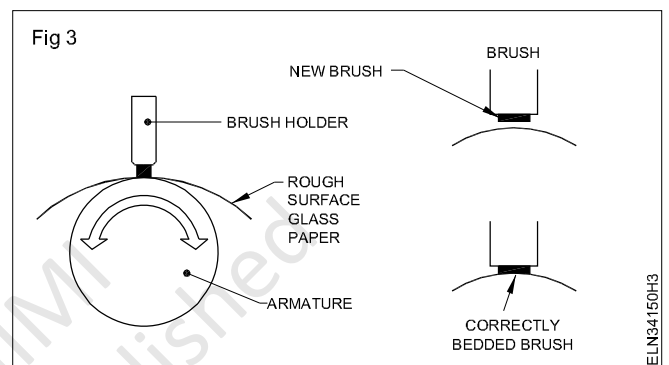

- h) Check the bearing for ply or damage.
- i) Replace the damaged or defective bearing with the new one having same specification.

If the old bearing is good, then clean the bearing and repack the bearing with grease approved by the manufacturer.

- j) Assemble the motor.
- k) Check whether the rotor shaft is free to rotate.

In case, the rotor shaft is hard to move or too tight, loosen the end covers and retighten them in a sequence till the rotor is free to rotate.

- l) Check the brush tensions and if necessary adjust it.
- m) Perform the earlier tests and enter the results in Table 3.

The present test results should be better than earlier ones. If not try to investigate the problem area and rectify.

- n) Check the earth connections of the motor, starter and switch and correct them if necessary.
- o) Start the motor with partial load and check its performance.
- p) Check for undue raise in motor temperature, noise and vibrations.
- q) Verify the defect following the trouble shooting chart if necessary.

Install an alternator, identify part and terminals of alternator

- Objectives:** At the end of this exercise you shall be able to
- select the location and type of foundation
 - determine the type of fasteners and prepare the Template
 - dig pit on the floor and prepare the concrete mixture
 - place fasteners with a template and grout the fasteners
 - read and Interpret the name plate details of alternator set
 - identify their parts and write their names
 - identify the terminals of alternator.

Requirements			
Tools/Instruments		Equipments/Machines	
• Right spanner set 5 mm to 25 mm	- 1 Set	• Electric drilling machine	- 1 No.
• DE spanner set 5mm to 25mm	- 1 No.	• 3 Phase Alternator 3KVA 500V 50 Hz coupled to suitable motor	- 1 No.
• Dial gauge	- 1 No.	• Ohm meter	- 1 No.
• Feeler gauge	- 1 No.	• Phase sequence meter	- 1 No.
• Ball pein hammer 1 Kg	- 1 No.	Materials	
• Cold chisel 19mm dia 200mm long	- 1 No.	• PVC insulated copper cable 2.5 sq mm 600V grade	- as reqd
• Round file bastard 200mm	- 1 No.	• Test lamp 250V	- 1 No.
• Flat file bastard 200 mm	- 1 No.	• Bolts and nuts	- as reqd
• Steel rule 300 mm	- 1 No.	• Cement	- as reqd.
• Crowbar 1800mm	- 1 No.	• Sand	- as reqd.
• Lead hammer 1 Kg	- 1 No.	• Earth wire GI 14 SWG	- 3 m
• Screwdriver 300mm with 6 mm blade	- 1 No.		
• Spirit level 200 mm	- 1 No.		
• Alignments pins (Fixture pin)	- 1 Set		

PROCEDURE

TASK 1: Install an alternator set

- 1 Select the Proper place of Installation for the alternator set.
- 2 Select a suitable type of foundation by referring to the manufacture's Instructions.
- 3 Select a suitable fastener by referring to the manufacturers's instructions.
- 4 Take the measurement of the bed frame as in Fig 1 and enter the data in Table 1.

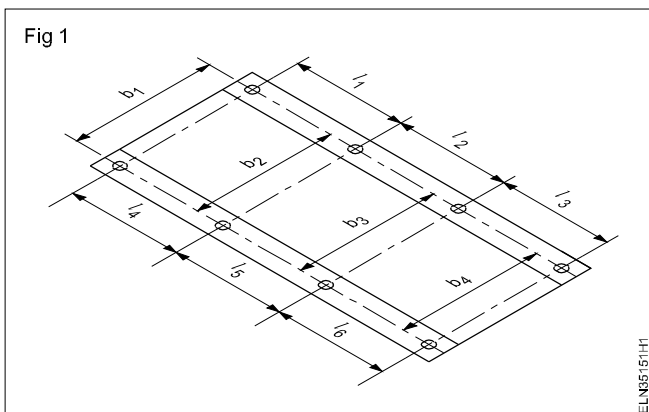

Table 1

Outside dimensions

Lengthmm
Breadthmm
Heightmm

Table 2

Distance measured from the adjacent holes

l ₁mm	l ₄mm	b ₁mm	b ₄mm
l ₂mm	l ₅mm	b ₂mm	
l ₃mm	l ₆mm	b ₃mm	

- 5 Measure the position and size of foundation bolt holes and enter the data in Table 2.
- 6 Prepare a template for the bed frame , mark the position of the foundation bolt on the template and drill the frame. (Fig 2)

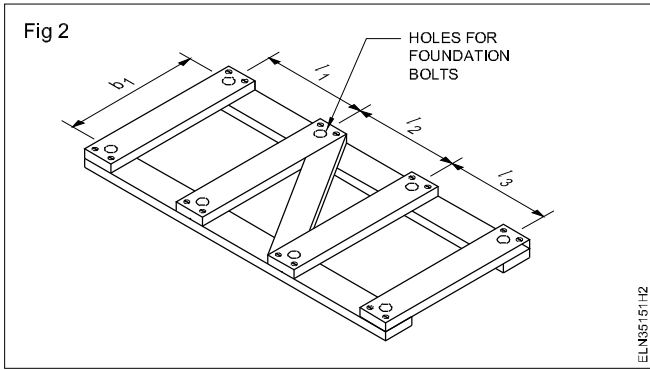

- 7 Mark the position of the foundation bolts in the selected space on the floor using the template.
- 8 Dig the floor at the marked places, such that the depth of holes is 15 cm more than the length of the anchor bolt below the floor surface.
- 9 Mount the foundation anchor bolts in the template and place the template on the ground surface so that the anchor bolts enter the holes already dig in proper position.
- 10 Check for level using the spirit level.
- 11 Fill the space around the bolt with thin coarse cement mortar.

- 12 Allow it to settle down for 8 to 12 hours, then remove the template.
- 13 Cure the cement mortar with water for a minimum of two days.
- 14 Finish the surface by plastering neatly.
- 15 Install the alternator set and fix with nuts.(Fig 4)

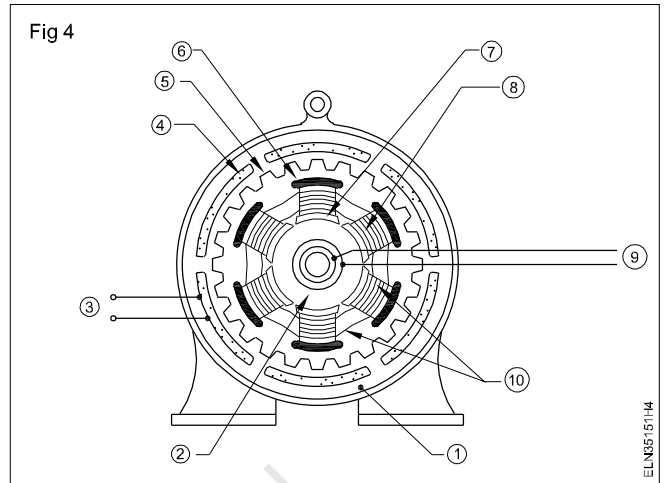

TASK 2 : Identify the parts of alternator

- 1 Read and interpret the name plate details of the given alternator and note down as on Table 3.
- 2 Identify the parts of the alternator from the real object or form the exploded view chart (Fig 3)

Table 3

Name-plate details

Manufacturer, Trade Mark :	Rated Speed:rpm.
Type model number :	Rated powerk.w/HP
Type of Current :	Rating class:.....
Function	Insulation class
Serial number :Amps	Rated current: :.....amp...
Type of connection:	Rated frequency.....Hz
Rated voltage:volts	Protection class:



- 3 Label the each part with number and write the name of the parts in Table 4.

Table 4

S No.	Label No.	Name of the part
1		
2		
3		
4		
5		
6		
5		

TASK 3 : Identify the terminals of a 3 phase, star connected alternator

In a 3-phase, star-connected alternator three windings are internally connected in the star and four terminals are brought out to the terminal block. These four terminals consist of three beginning ends of the 3-phase winding and one neutral.

- 1 Check there is any marking on the terminals and note it down also. If not, give your own marking as 1,2,3 etc as shown in Fig 4.

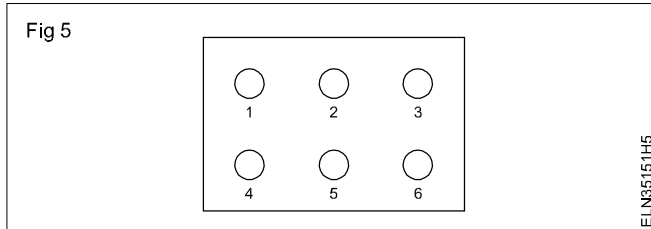

- 2 Identify the terminals which show the internal connection, following the procedure stated in the above working steps and also as shown in Fig 6a. Measure the resistance in between them and record the readings in Table 5.
- 3 Identify the field winding from the terminal block (Fig 6b)

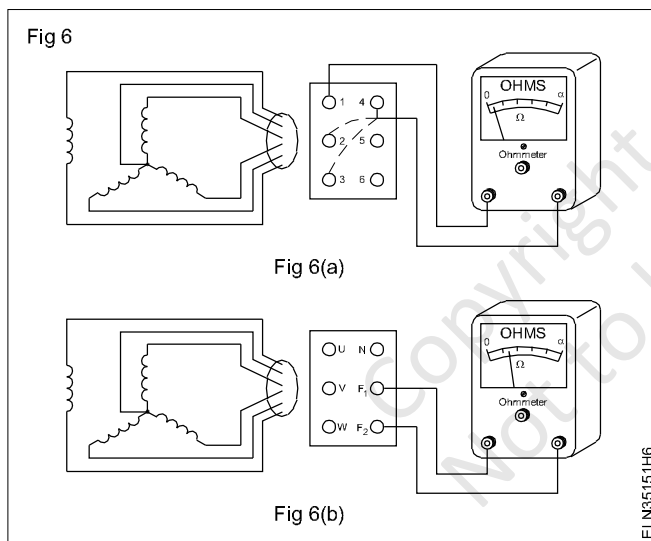

Only one pair will be independent with marginally high resistance. This pair belongs to the field winding. The other four terminals which show continuity between them belong to the star-connected, main winding terminals.

Out of the four terminals, three terminals will give comparatively high resistances between them. These are the ends of the three coils called UVW terminals. However, the left out terminal out of the four will give half the value of resistance when measured between any one terminal of UVW and that terminal. This terminal is the neutral and has to be marked as 'N'. The marking of the 3-phase terminals as UVW is tentative. The correct phase sequence is to be checked with the help of a phase-sequence meter, then only the terminals could be marked as UVW.

- 4 Mark the terminals accordingly.
- 5 Show your making to your instructor and get his approval.

Table 5

Sl No.	Between	Resistance value in ohms	Remarks
1	1 - 2		
2	2 - 3		
3	3 - 4		
4	1 - 3		
5	1 - 4		
6	2 - 4		
7	5 - 6		

Test for continuity and insulation resistance of alternator

Objectives: At the end of this exercise you shall be able to

- read and interpret the name-plate details of an alternator
- identify the terminals of a 3-phase alternator
- test the alternator windings for continuity
- test the insulation resistance between the stator and rotor windings
- test the insulation resistance, between the windings and the alternator frame.

Requirements			
Tools/Instruments		Equipment/Machines	
<ul style="list-style-type: none"> • Cutting pliers 200mm - 1 No. • Spanner set 5mm to 200mm - 1 Set • Screwdriver 200mm - 1 No. • Screwdriver 100mm - 1 No. • Megger 500V - 1 No. 		<ul style="list-style-type: none"> • Alternator, 3-phase, 3 KVA 415V - 1 No. 	
		Materials	
		<ul style="list-style-type: none"> • P.V.C. insulated copper wire 23/0.2 mm size - 5 m • Insulation tape - 1 m. • Test lamp 60W / 240V - 1 No. 	

PROCEDURE

TASK 1 : Read and interpret the name plate details of an alternator

- 1 Read and interpret the name-plate details of the 3-phase alternator and enter in Table 1.
- 2 Identify the terminals of the alternator as you did in Exercise No.3.5.151. Task : 3.

Table 1

Name Plate Details

Manufacturer, Trade mark :	
Type, model or list number :	
Type of current :	Fabrication or Serial number :
Function :	Alternator :
Type of connection :	P.F :
Rated voltage :Volts	Rated current : amp
Frequency :Hz	Rated speed :r.p.m.
Rated power :kVA	Rated exc. current :amps
Rated exc. voltage :Volts	Direction of rotation :
Rating class :	Protection class :
Insulation class :	

TASK 2 : Conduct continuity test by using a lamp

Table 2

- 1 Take the test lamp and identify the cable to which the S.P. switch and the fuse are connected in series with the lamp. Use this as Prod 1.
- 2 Connect Prod 2 to terminal 'N' and touch the terminals R, Y and B alternatively by Prod 1. (Fig 1) Observe the lamp condition and enter the same in Table 2.

SI.No.	Connection between	Condition of lamp
1	R and N	
2	Y and N	
3	B and N	
4	F ₁ and F ₂	

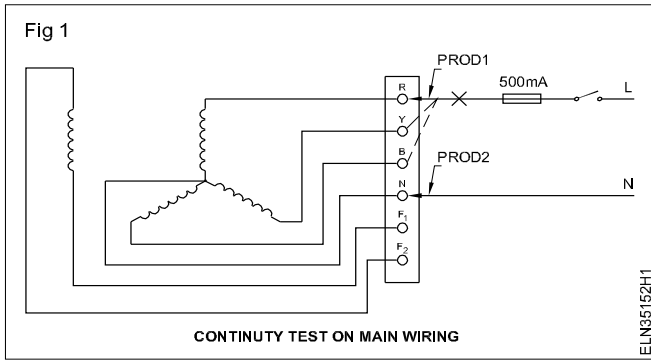

3 Check the continuity between F_1 and F_2 (Fig 2) and enter the finding in Table 2.

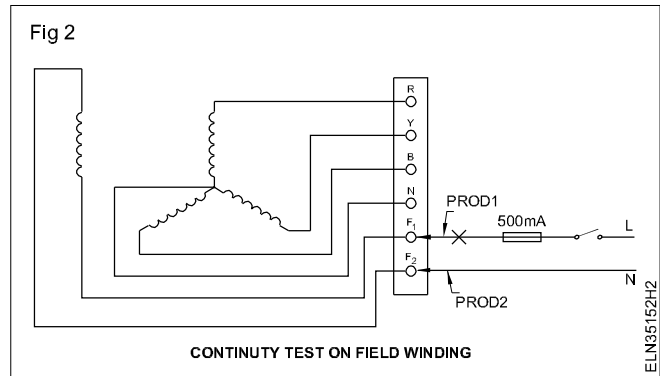

The phase wire should be identified in the test lamp as Prod 1, and should be connected through the switch and fuse to the test lamp. Care should be taken to see that the phase wire does not touch the body or frame of the alternator. Do not touch any terminal while testing with AC supply.

TASK 3 : Measure insulation resistance between windings

- 1 Connect one prod of the Megger to any one of the terminals R, Y, B, N and the other prod to the terminal F_1 or F_2 as shown in Fig 3.

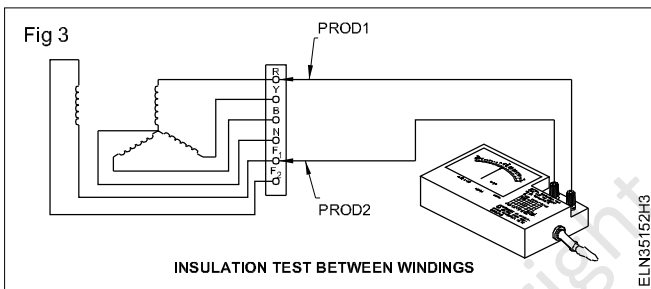

You can connect to any one of the terminals R, Y, B and N as all of them are having continuity as ascertained earlier.

- 2 Rotate the Megger at its rated speed and measure the insulation value and record it in Table 3.

The measured value should not be less than 1 megohm.

Table 3

Sl. No.	Insulation resistance between windings	Value in megohms
1	Between RYBN and field winding F_1 & F_2	

TASK 4: Measure the insulation resistance between the windings and the body

- 1 Connect one of the prods of the Megger to any one terminal, RYBN and the other prod to the body/frame of the alternator. (Fig 4)
- 2 Rotate the Megger at its rated speed and measure the insulation resistance. Record it in Table 4.

Table 4

Sl. No.	Insulation resistance between winding and the body	Value in $M\Omega$
1	Between armature winding R/Y/B/N and the body	
2	Between field winding F_1 & F_2 and body	

- 3 Connect the Megger prod to terminal F_1 or F_2 and the other prod to the body. (Fig 5)

Rotate the Megger at its rated speed and measure the insulation resistance value, and record it in Table 4.

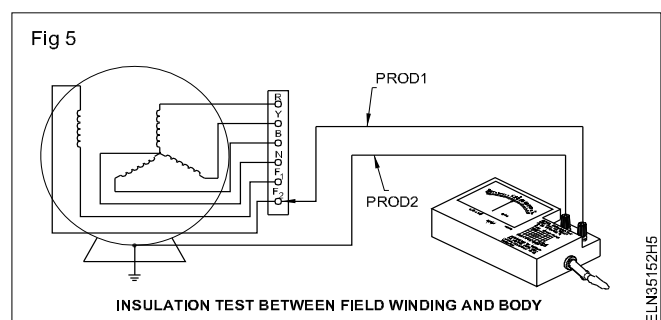
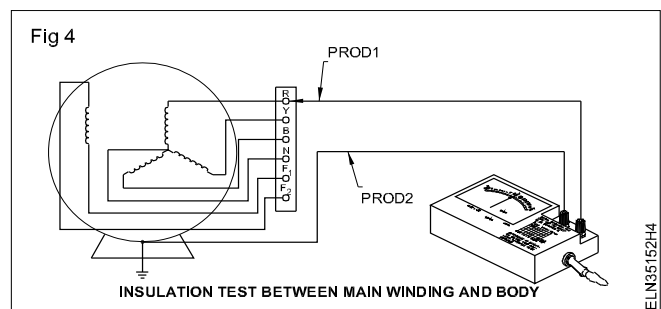

The measured insulation value should not be less than 1 megohm.

- 4 Compare these values of insulation resistance with those entered in the alternator maintenance card available in the section, and discuss the variations in the reading with your instructor.

Copyright @ NIMI
Not to be Republished

Connect, start and run an alternator and build up the voltage

Objectives: At the end of this exercise you shall be able to

- read and interpret the name-plate details of an alternator
- test and identify the terminals of an alternator
- connect, start, run, adjust the speed and frequency of the alternator
- adjust and set the rated voltage of an alternator
- determine the magnetisation characteristic of an alternator.

Requirements

Tools/Instruments

- Insulated cutting pliers 200mm - 1 No.
- Screwdriver 150mm - 1 No.
- Screwdriver 100mm - 1 No.
- Voltmeter AC 0 to 500 volts - 1 No.
- Ammeter DC 0 to 5 amps - 1 No.
- Tachometer 0 to 3000 r.p.m. - 1 No.
- Single phase frequency meter 250V - 45 to 55 Hz. - 1 No.

Equipment/Machines

- 3-phase alternator 3KVA 415V 50 Hz. coupled to a suitable DC motor. - 1 Set

- Rheostat 480 ohms 2 amps - 2 Nos.
- 4-point starter 30 amps 250V - 1 No.

Materials

- PVC insulated copper cable 2.5 sq mm 600 V grade - 10 m.
- Insulation tape - 30 cm.
- Fuse wire 5A, 15A - as reqd.
- T.P.I.C. switch 16 amps 500V - 1 No.
- D.P.I.C. switch 32 amps 250V - 2 Nos.

PROCEDURE

TASK 1: Connect, start, run, adjust the speed and frequency of an alternator

- 1 Read and interpret the name-plate details in Table 1.
- 2 Test and identify the terminals of the alternator.
- 3 Test the alternator for insulation resistance between the windings, the winding and the ground, and record the values separately.

The insulation resistance value should not be less than one megaohm

- 4 Select a suitable range of rheostats, ammeters, voltmeters, switches and cables according to the specification of the available alternator.

You may have to change the ranges of the meters and rheostat according to the rating of the available alternator with respect to Fig 1.

- 5 Make the connections as per the circuit diagram. (Fig 1)
- 6 Adjust the field rheostat of the prime mover to cut out position, and the field rheostat of the exciter in the minimum voltage position.
- 7 Check the couplings.

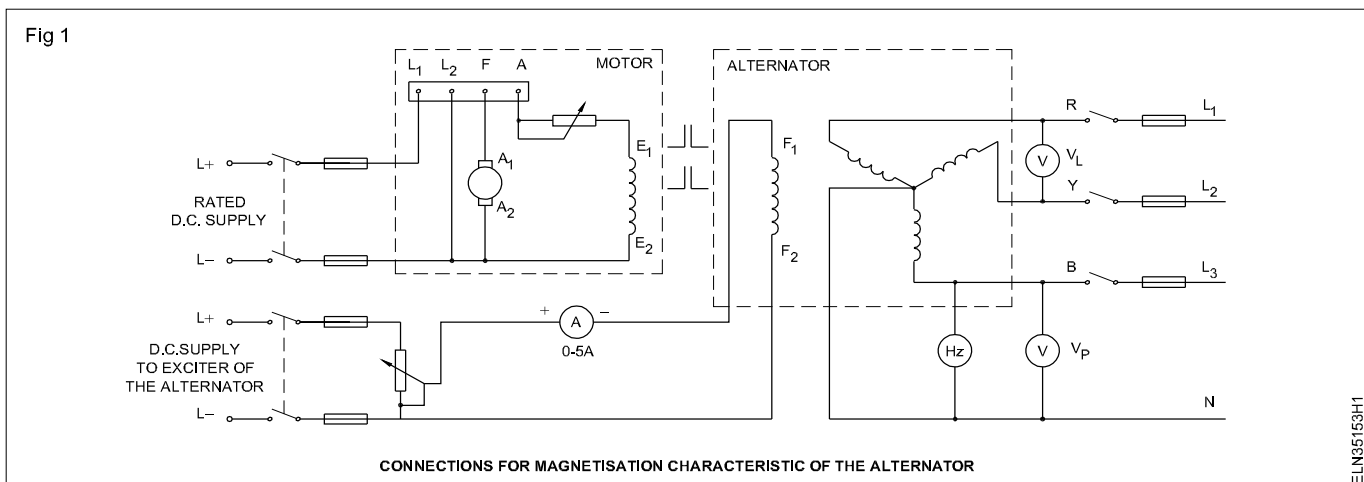

Table 1

Name plate details

Manufacturer, Trade Mark	:	Fabrication or serial number	:
Type, model or list number	:	Alternator	:
Type of Current	:	P.F.	:
Function	:	Rated current	:amps
Type of connection	:	Rated speed	:r.p.m.
Rated voltage	:Volts	Rated exc. current	: amps
Frequency	:Hz	Direction of rotation	:
Rated power	: kVA	Protection class	:
Rated exc. voltage	: Volts		
Rating class	:		
Insulation class	:		

- 8 Switch 'ON' the DC supply to the prime mover (DC motor) and start the prime mover through the 4-point starter.
- 9 Adjust the speed of the prime mover through its field rheostat to the rated speed of the alternator.
- 10 Switch 'on' the DC supply to the exciting winding of the alternator. Note down the field current, line voltage and phase voltage of the alternator in Table 2.
- 11 Note down the frequency (if possible, for the frequency meter may not read at a low voltage) in Table 2.
- 12 Increase the field current in 10 to 12 equal steps. For each step measure the phase voltage, line voltage, frequency and field current and enter the values in Table 2 until the alternator output voltage reaches its rated value.

- 13 Increase the excitation current such that the alternator line voltage is about 10% above the rated value.
- 14 Draw the curve I_F versus V_p taking I_F on the 'X' axis and V_p on the 'Y' axis. The curve shows the O.C.C. or the magnetisation characteristic of the alternator.
- 15 Write your conclusion regarding the relation between the field current and phase voltage as well as the line voltage and phase voltage.

Conclusion

The field current should be varied gradually in equal steps in the ascending order. Otherwise it will disturb the shape of the plotted curve.

Table 2

Sl.No.	Field current I_F	Line voltage V_L	Phase voltage V_p	Frequency V_F	Remarks

Determine the load performance and voltage regulation of a 3-phase alternator

Objectives: At the end of this exercise you shall be able to

- connect, start, run, and build up the voltage of an alternator
- connect the resistive, inductive load to the 3 phase alternator
- determine the voltage regulation of an alternator.

Requirements

Tools/Instruments

- Combination pliers 200mm - 1 No.
- Round nose pliers 150mm - 1 No.
- Electrician's knife - 1 No.
- M.I. ammeter 0 to 20 amps - 3 Nos.
- M.I. voltmeter 0 to 500 volts - 1 No.
- M.C. voltmeter 0-300V - 1 No.
- M.C. ammeter 0-5A - 1 No.
- Frequency meter 500V, 45 to 50 Hz. - 1 No.
- Power-factor meter 500V, +0.5 to -0.5 P.F. - 1 No.
- Tachometer 300 to 3000 r.p.m. - 1 No.

Equipment/Machines

- 3-phase alternator 500V 5/10 kW coupled with DC shunt motor having facility for speed control - 1 Set
- 3-phase lamp load 415/400V 5 KW - 1 No.
- 3-phase squirrel cage motor 500V 50HZ, 3 HP with DOL starter and switch - 1 No.

Materials

- P.V.C. insulated stranded aluminium cable - 10 m
- T.P.I.C. switch 32 amps 500v - 2 Nos.

PROCEDURE

TASK 1 : Connect, start, run, and build up the voltage of an alternator

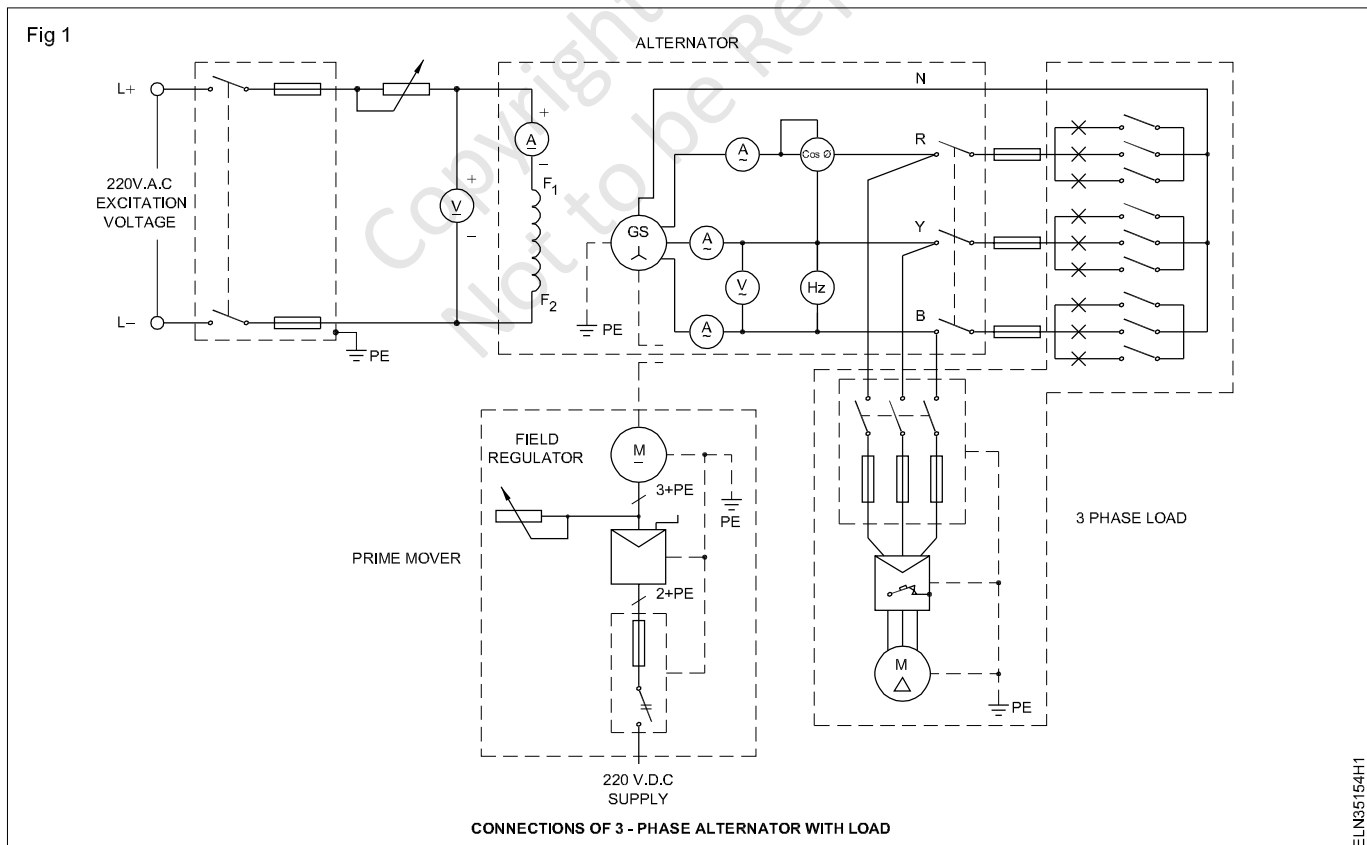

- 1 Note down the name-plate details of the given alternator in Table 1. (As per exercise 3.5.152 Task : 1)

- Select proper sizes of cables, fuse wires, switches etc., as per the name-plate ratings (rated capacity) of the given 3-phase alternator.
- Connect the exciter output terminals to the field of the alternator with the rheostat, ammeter and voltmeter. (Fig 1)

The exciter output voltage is shown in Fig 1 as 220V DC. Different manufacturers choose different exciter voltages suitable for their alternators. You may have to select the voltmeter and ammeter ratings according to the voltage rating of the field of the available alternator.

- Connect the alternator terminals RYB and N to the load as per the circuit diagram (Fig 1). Keep the load switches and also all the lamp switches of the lamp load in the 'off' position.

Check the voltage rating of the power factor and frequency meters whether they are for phase voltage or line voltage. Connect accordingly. Do not forget to connect the star point of the lamp load to the neutral point of the alternator. The bulb wattage rating should be equal in all lamps.

- Show the connection to your instructor and obtain his permission to start the prime mover.
- Run the alternator at its rated speed. Measure and record the speed. Speed..... r.p.m.
- Build up its voltage by adjusting the field rheostat to the rated voltage of the alternator. Read and record it. Voltagevolts.

TASK 2 : Load a 3-phase alternator with a resistive load

- Close the T.P.I.C. switch of the lamp load and note down the values of the load current, (which will be zero), the terminal voltage, P.F. and frequency in Table 2.

The frequency should be kept constant by adjusting the prime mover speed whenever necessary.

- Slowly increase the load current to 1 amp by switching 'ON' the lamps one by one. Record all the readings in Table 2.

Switch on the lamps equally in all the three phases so that the load is balanced.

- Increase the load current equally on all the three phases of the alternator to its rated value by switching on the lamps in steps of 1 amp. For each step, note down the current, voltage and the P.F. frequency and tabulate the readings in Table 2.
- Reduce the load gradually to zero. Open the lamp load by switching off the T.P.I.C. switch.

Table 2

Sl. No.	Load current equal in all the three phases I_L	Terminal Voltage V_L	Frequency kept constant	Power Factor $\cos \phi$	Power = $\sqrt{3} E_L I_L \cos \phi$	Remarks

TASK 3 : Load a 3-phase alternator by a 3-phase motor (inductive) load

- Close the T.P.I.C. of the motor load and start the motor by the D.O.L starter. Read and record $I_L, V_L, P.F$ and frequency in Table 3. Switch 'OFF' the T.P.I.C. switch of the motor load.

Table 3

Sl. No.	Load current equal in all the three phases I_L	Terminal Voltage V_L	Frequency kept constant	Power Factor $\cos \phi$	Power = $\sqrt{3} E_L I_L \cos \phi$	Remarks

TASK 4 : Determine the voltage regulation of an alternator

- 1 Close the T.P.I.C. switch of the motor load and start the motor by the D.O.L starter.
- 2 Close also the T.P.I.C. switch of the lamp load and increase I_L up to the alternator's rated value in steps of one ampere. Read and record the values of I_L , V_L & P.F. frequency in Table 4.
- 3 Reduce the load and switch off the alternator.
- 4 Draw the three curves for the 3 sets of reading as recorded in Tables 2, 3 and 4 in the same graph showing the terminal voltage versus load current. Keep the terminal voltage in the Y axis and load current in the X-axis.
- 5 Compare the power delivered to the
 - resistive
 - inductive (partially resistive)
 - resistive/inductive loads
 - with the corresponding line current and line voltage, and P.F.- atleast three different line current values.

- 6 Calculate the voltage regulation for the above different loads at 5 and 10 amperes by using the formula:

Percentage voltage regulation ($\%V_R$)

$$\%V_R = \frac{\text{No.load voltage} - \text{Full load voltage}}{\text{Full load voltage}} \times 100$$

- 7 Based on steps 5 and 6 write your conclusion in the space given below.

Conclusion 1

Conclusion 2

Table 4

Sl. No.	Load current equal in all the three phases I_L	Terminal Voltage V_L	Frequency kept constant	Power Factor $\cos \phi$	Power = $\sqrt{3} E_L I_L \cos \phi$	Remarks

Parallel operation and synchronization of three phase alternators

Objectives: At the end of this exercise you shall be able to

- read and interpret the name plate details of the two 3 phase alternators
- synchronise the two 3 phase alternators by dark lamp method and test it
- synchronise the two 3 phase alternators by dark and bright lamp method and test it
- synchronise the two 3 phase alternators by synchroscope method and test it.

Requirements			
Tools/Instruments			
• Trainees tool kit	- 1 No.	• Rheostat 150 ohms/1A	- 1 No.
• MI Voltmeter 0-500V	- 2 Nos.	Materials	
• Frequency meter (45 - 50 - 55 Hz)	- 1 No.	• TPIC switch 16A, 500V	- as reqd.
• Phase sequence indicator	- 1 No.	• ICDP / Knife switch 16A, 250V	- 1 No.
• Synchroscope	- 1 No.	• ICTP / Knife switches 16A, 500V	- 2 Nos.
Equipments/Machinery			
• 3 Phase alternators 5 kVA/500V 50 Hz coupled with prime mover (/adjustable speed control)	- 2 Nos.	• 100W/250 V lamps	- 6 Nos.
		• Connecting wires	- as reqd.

PROCEDURE

TASK 1 : Read and interpret the name plate details of the alternators

- 1 Read and interpret the name plate details of the 3 phase alternator
- 2 Note down the details of alternators in Table 1.

Table 1

Name-plate details

Manufacturer, Trade Mar k.....	Rated frequency
Type, model or list number	Rated powerkw/HP
Type of current	Rating class
FunctionAlternator.....	Insulation class
Fabrication or serial number	Rated current.....amp
Type of connection	Rated speedr.p.m
Rated Exc.currentamps	Rated exc.Voltage.....V
Rated voltage volts	Protection class
Direction of rotation :.....	

The voltage rating of two alternators must be same. Rating of alternators (kVA), not necessary must be same. The load can be shared according to the rating of alternators.

TASK 2 : Synchronise the two 3 phase alternator by dark lamp method and test it

For connecting two alternators in parallel they must fulfil the following conditions.

- 1 Terminal voltage of both the alternators must be same

- 2 Supply frequency of both alternators must be equal

- 3 Phase sequence of both the alternators must be ideal

- 1 Check the phase sequence of the main bus bar line by using phase sequence indicator/meter
- 2 Connect and set the arrangement of incoming alternator and outgoing alternator with prime mover coupled, TPIC main switch, voltmeters and frequency meters and lamp connection in series. (Fig 1).

While connecting the alternators, care should be taken, that corresponding phase lines must be connected of both alternators. (i.e.) 1st alternator is connected to L1, L2 and L3 then the 2nd alternator must also be connected to same L1, L2 and L3.

- 3 Keep the main switch of incoming alternator -1 in closed position after ensuring the phase sequence are correct.

- 4 Keep the main switch of alternator - 2 in opened position.
- 5 Start and run the first alternator and build up the rated voltage
- 6 Measure the line voltage between phases, then measure the frequency of an alternator-1 and note down the readings of voltmeter and frequency meters in Table 2.

Table 2

Alternator 1

S No.	Voltage reading in Volt	Frequency in Hz
1	L1 - L2	L1 - L2
2	L2 - L3	L2 - L3
3	L3 - L1	L3 - L1

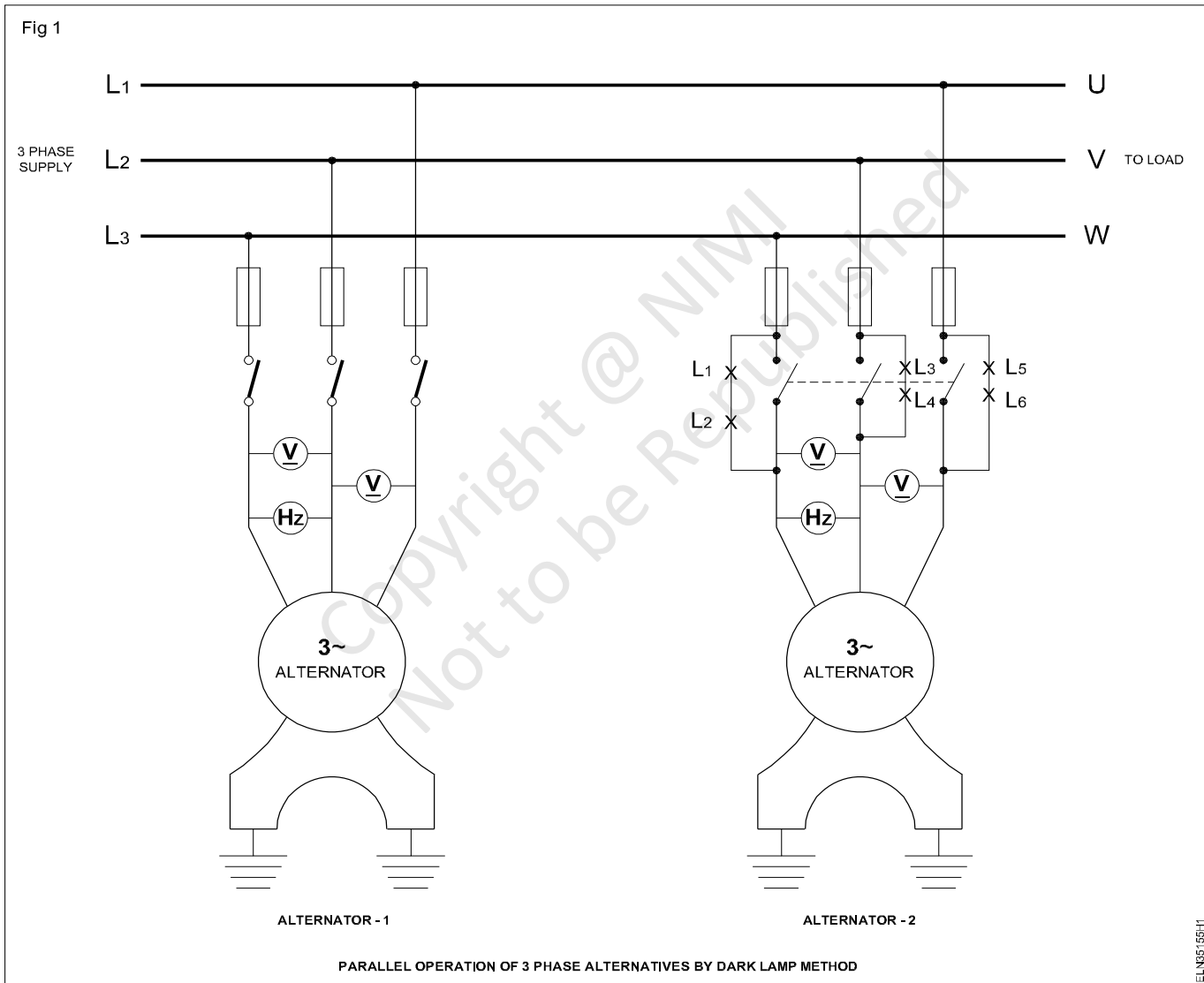

- 7 Start , run and build up the rated voltage
- 8 Measure the line voltages and frequency in alternator 2 and note down the readings in Table - 3

Table 3

Alternator 2

S No.	Voltage reading in Volt	Frequency in Hz
1	L1 - L2	L1 - L2
2	L2 - L3	L2 - L3
3	L3 - L1	L3 - L1

9 Check the condition of the two lamp.

If the voltage and frequency are equal the lamps will become dark and then become bright. If the voltage and frequency of the both alternators are not same, the lamps will flicker.

10 Adjust the field excitation current in the alternator 2 and bring the voltage to the same value of the alternator 2.

11 Check the condition of lamps brightness.

If the lamps are flickering still now, then the frequency may not be equal, it must be brought to same equal frequency value of alternator 1

12 Adjust the speed of the prime mover of alternator 2 and bring the frequency as same as in alternator 1

Now, all the lamps are bright and then become dark at a time, it indicates all the conditions are fulfilled for synchronising.

13 Close the main switch of alternator - 2 when all the lamps are in dark condition.

Now the alternators are synchronised (parallel) and ready for sharing the load

14 Switch 'ON' common load for both the alternators.

15 Check the loads are shared equally by the two alternators.

16 Get it checked with your instructor.

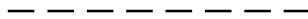

TASK 3 : Synchronise the two 3 phase alternators by dark and bright lamp method

1 Check the phase sequence of the main bus bar lines by using phase sequence indicator

2 Connect and set up the arrangement of the alternator - 1 and alternator - 2 with prime mover, TPIC switch, lamp connection. (2 pairs of lamp are connected across two phases, In one phase, the pair of the lamps are in series with voltmeters and frequency meters. (Fig 2)

3 Repeat the working steps from 3 to 8, in Task - 2

4 Note down the readings in table - 4 & Table - 5

5 Look at the condition of the lamps

If the voltage and frequency are equal then one pair of the lamp will be dark and other two pair will be bright

If the voltage and frequency of the both the alternators are not same, then the lamp will flicker not giving standstill lighting

6 Check the voltage and frequency are not equal repeat the steps from 10 to 12 of task 2 and bring the same value of voltage and frequency as in alternator - 1

If all the condition are fulfilled, then all the lamps will not flicker and one pair of the lamp will be dark and other two pair lamps will be bright at a time.

7 Close the main switch of alternator - 2 when the lamps are bright condition

Now the 2 alternators are synchronised (parallel) and ready for sharing the load

8 Switch 'ON' the common load for both alternators

9 Check the loads are shared equally by the two alternators

Table 4

Alternator - 4

S. No.	Voltage reading in Volt	Frequency in Hz
1	L1 - L2	L1 - L2
2	L2 - L3	L2 - L3
3	L3 - L1	L3 - L1

Table 5

Alternator - 5

S. No.	Voltage reading in Volt	Frequency in Hz
1	L1 - L2	L1 - L2
2	L2 - L3	L2 - L3
3	L3 - L1	L3 - L1

Fig 2

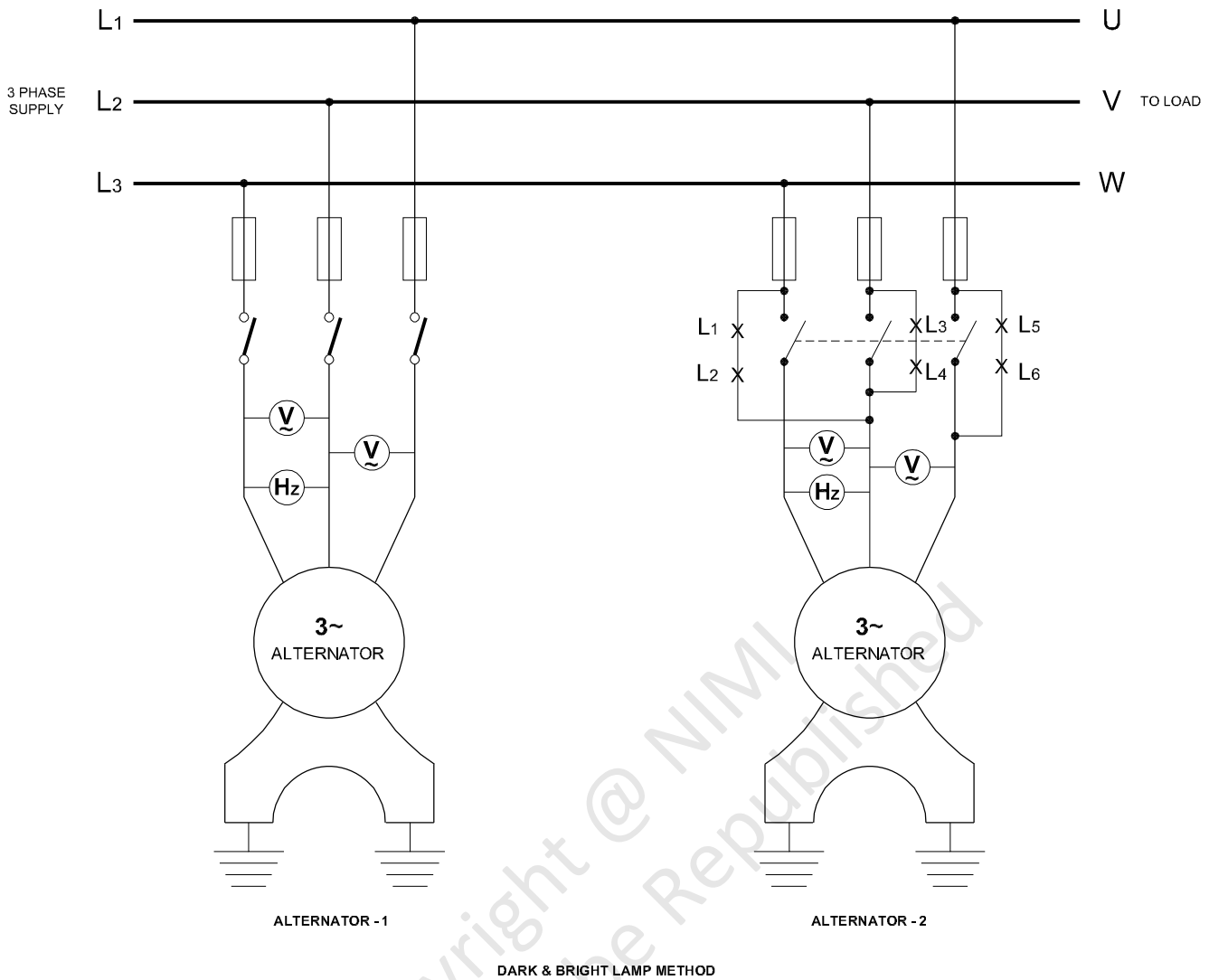

TASK 4 : Connect two alternators in parallel by using synchroscope

- 1 Collect the instruments as shown. (Fig 3)
- 2 Connect the equipment and instruments. (Fig 3)

Keep 'open' the bus-bar switch S_1 and synchronising switch S_2 .

- 3 Start the incoming alternator (Alternator-2) with low excitation.
- 4 Close the bus-bar switch S_1 .

One alternator (Alternator-1) is connected to the bus-bar that produces the rated V .

- 5 Observe the bus-bar voltage V_1 and incoming voltage V_2 .
- 6 Adjust the excitation of the incoming alternator till $V_1 = V_2$. The voltage of incoming and exciting machine should be equal.
- 7 Check the pointer in the synchroscope.

- 8 Adjust the speed of the alternator. If it is indicating fast, reduce the speed of the incoming machine gradually observing the synchroscope pointer.

If it indicates slow, increase the speed of incoming machine slowly. The result should be slow movement of the pointer to 0.

When the pointer comes to zero position very slowly, the bulb behind the dial will glow bright.

- 9 Adjust the speed of the incoming alternator for minimum oscillation of the synchroscope pointer.
- 10 Close the synchronising switch ' S_2 ' at zero, and the steady position of the synchronising pointer.

When the two voltages of the incoming and existing machines are the same in magnitude and phase, synchroscope pointer will be at zero.

Fig 3

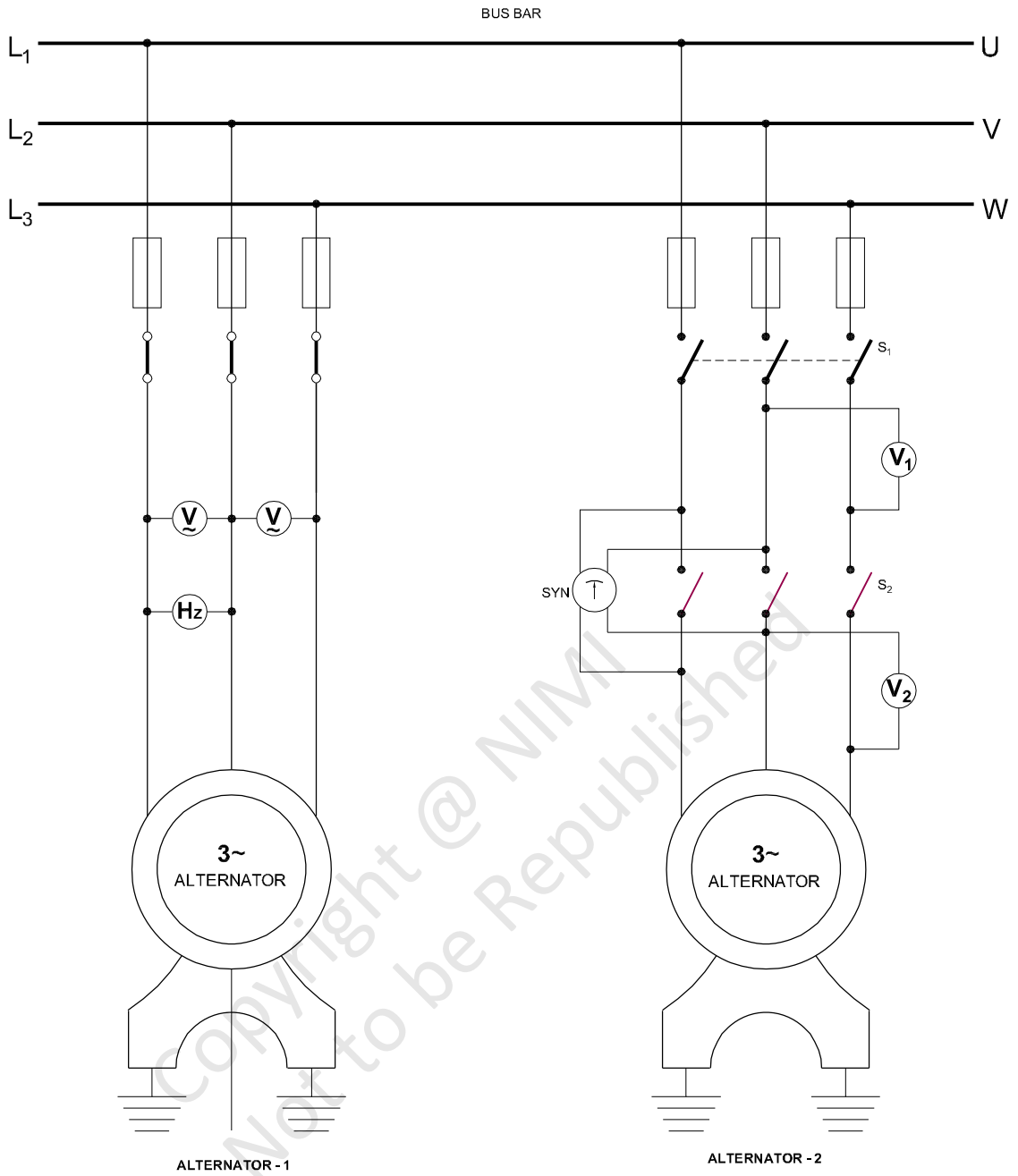

TWO ALTERNATORS IN PARALLEL BY USING SYNCHROSCOPE

ELN2051:65:13

Install a synchronous motor, identify its parts and terminals

Objectives: At the end of this exercise you shall be able to

- read and interpret the name plate details of given shynchronous motor
- read the manufacturers installation instruction and follow the same
- tranfer the template measurements to the mounting base
- make the template of the base frame making (i.e) making drilling, selecting hole size
- identify the parts of synchronous motor
- Identify the terminals of a synchronous motor.

Requirements			
Tools/Instruments			
• Masonry tools like travel Spirit level etc.	- 1 Set	• DC source/rectifier suitable for above motor	- 1 No.
• Drilling machine electric 12.mm capacity with drills	- 1 No.	• TPIC switch 32A, 500V	- 1 No.
• Measuring tape 3 meters	- 1 No.	• DPIC switch 16A 250V	- 1 No.
• Electrician hand tool kit	- 1 Set	• Suitable field Rheostat	- 1 No.
Equipment/Machines			
• Synchronous motor 3 KVA, 500V. 3 phase 50Hz with suitable starter	- 1 No.	Materials	
		• Connecting cables	- as reqd.
		• Plywood 8mm thick 40 x 30 cm	- 1 No.
		• Nuts grouting bolts	- 4 Nos.

PROCEDURE

TASK 1 : Install a given synchronous motor

- 1 Read the name-plate details and record in the motor maintenance card

Name plate details

Manufacturer	:	Speed	:rpm
Type	:	Insulation Class	:
Serial No.	:	Excitation voltage	:
Function	:	Excitation Current	:
Type of connection	:	Direction of Rotation	:
Voltage	:Volt	Rating Class	:
Current	:Amp		
Power	: KW	Protection	:

- 2 Make the necessary arrangement at the place where the motor to be installed as per manufacture's Instruction, such as drilling holes, position of nuts and bolts or and RCC foundation etc.
- 3 Determine the size of the connecting cable and fuse from the rating of the motor.
- 4 Cut two straight pieces and two cross pieces of ply wood (Fig 1) and mark the holes according to the size of the holes of the base of the motor on the wooden frame planks.
- 5 Select the size of the drill according to the size the mounting bolt recommended by the manufacturer.

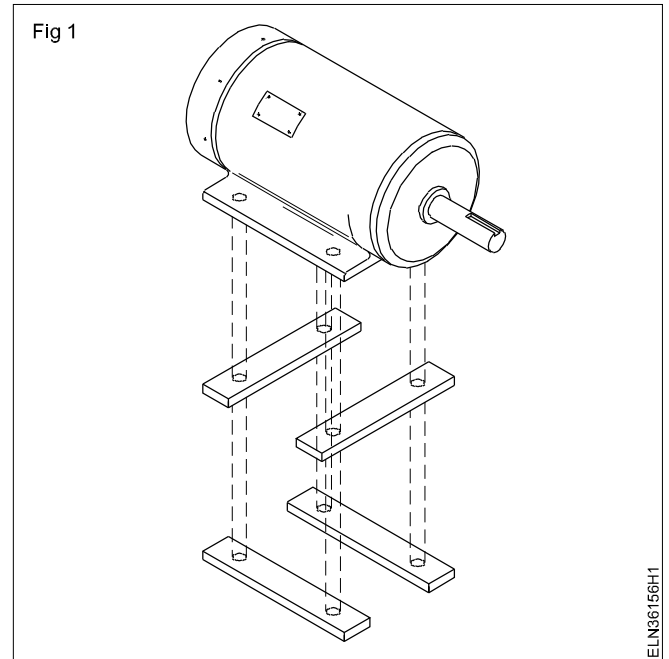

TASK 2 : Identify the parts of synchronous motor

- 1 Identify the parts of the synchronous motor from the real object or from the exploded view chart. (Fig 1)
- 2 Label the each identified parts with number tags.
- 3 Write the name of the parts of each labelled number in the table.

Table

SI. No.	Lable No.	Name of Part

- 6 Drill the holes according to the size mentioned.
- 7 Make use of the template measurements on the mounting base and get the base mounting ready for installing the motor. (Fig 2)
 - a) Fix the planks with a grouting bolt.
 - b) Check for level using the spirit level.
 - c) Fill the space around the bolts with thin coarse cement mortar.

In the training Institute use clay mortar instead of cement to facilitate repetition easily by every trainee in a batch.

- d) Allow it to settle down for 8 to 12 hours, then remove the template planks.
- e) Cure the cement mortar with water for a minimum of 2 days.

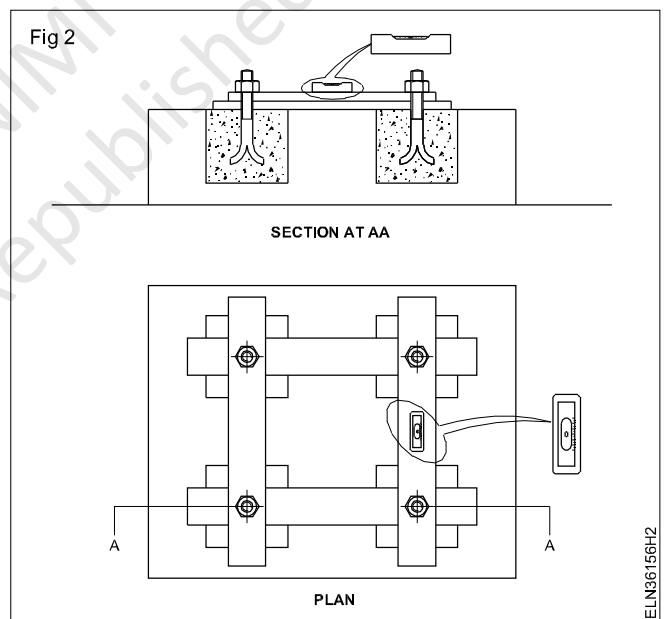

- f) Finish the surface by plastering neatly.

Include vibration arresting devices as per the manufacturer's instructions such as spring washers, etc.

- 8 Install the motor and fix it with nuts (Fig 3)
- 9 Make double earthing in accordance with I.E. regulations and I.S. recommendation.
- 10 Check the continuity of windings as shown in Fig 4. Also check the effectiveness of grounding. (Fig 5)
- 11 Connect the motor with the starter/switch and fuse to the supply temporarily to check smooth running without vibrations.

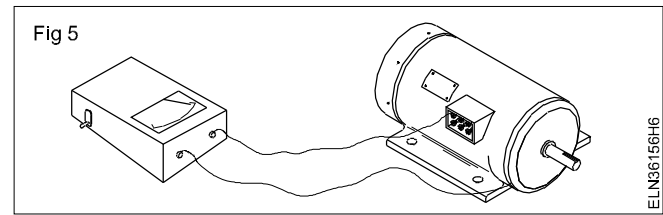
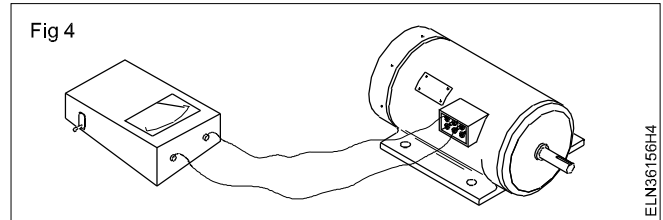
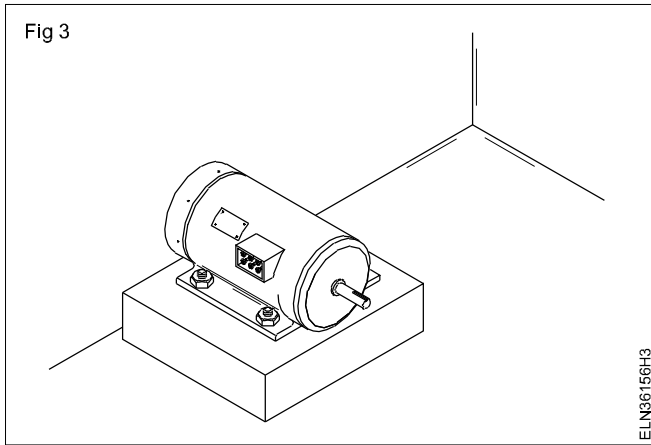

Copyright @ NIMI
Not to be Republished

Connect start and plot V-curves for synchronous motor under different excitation and load conditions

Objectives: At the end of this exercise you shall be able to

- connect the synchronous motor with its starter
- start and run the synchronous motor with its starter
- plot the 'V' curve.

Requirements	
Tools/Instruments	
<ul style="list-style-type: none"> • Trainees tool kit - 1 No. • MI Ammeter 0-10 A - 1 No. • MC Ammeter 0-1 A - 1 No. • MI Voltmeter 0-500 V - 1 No. • Frequency meter (45-50-55Hz) - 1 No. • Tachometer 0-10000 rpm - 1 No. 	<ul style="list-style-type: none"> • DC source/rectifier suitable for above motor - 1 No. • TPIC switch 32A, 500V - 1 No. • DPIC switch 16A 250V - 1 No. • Field rheostat suitable for above motor - 1 No.
Equipment/Machines	
<ul style="list-style-type: none"> • Synchronous motor 3 KVA, 500V 3 phase 50Hz with suitable starter - 1 No. 	Materials
	<ul style="list-style-type: none"> • Connecting leads - as reqd.

PROCEDURE

TASK 1: Connect the synchronous motor, start, run and test it

1 Make the connections as per circuit diagram. (Fig 1)

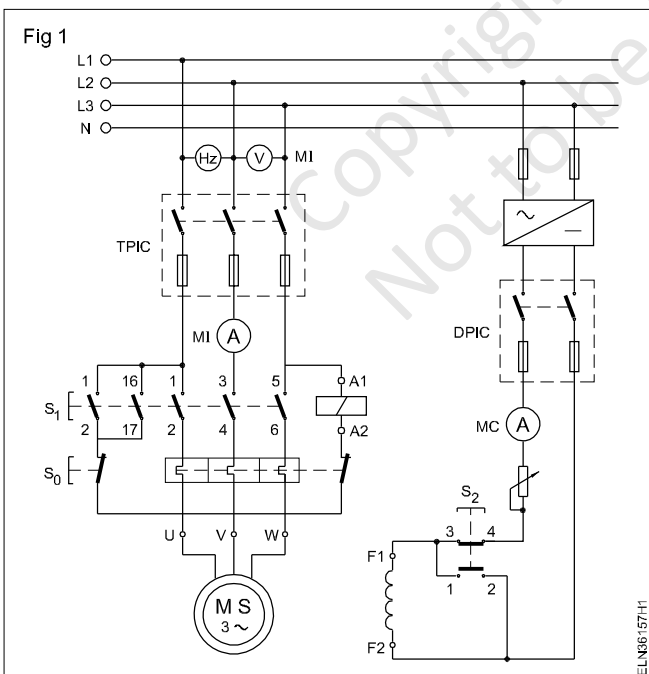

5 Hold push button S_2 depressed, and start the motor by operating switch S_1 .

Make sure that push button S_2 is pressed before energising the motor at the time of starting.

When S_2 is depressed DC supply to field is disconnected and field winding terminals F1 and F2 are shorted.

6 After the rotor attains maximum speed say 95% of the synchronous speed release push button S_2 i.e. field winding is excited by DC supply.

With field winding excited the motor gets pulled into synchronism and runs at synchronous speed.

7 Measure speed, supply voltage, frequency, line current, and field excitation current and record in Table 2.

Table 2

Line voltage	: _____ Volt
Line current	: _____ amp
Excitation current	: _____ amp
Speed	: _____ r.p.m
Frequency	: _____ Hz

2 Show the connections to your instructor and get his approval.

3 Close TPIC switch and DPIC.

4 Adjust the field current to its rated value as per name plate detail.

8 Calculate the synchronous speed of the motor by using the formula.

$$N_s = \frac{120f}{p}$$

Synchronous speed $N_s = \dots$ rpm.

- 9 Compare the synchronous speed with the measured speed, and ensure measured speed is equal to synchronous speed.

TASK 2 : Plot the V-Curve for synchronous motor under different excitation and load condition

- 1 Start and run the synchronous motor to its maximum speed without load.
- 2 Adjust the field current by adjusting the field rheostat (Fig 1) and take the readings of armature current (I_a) and field current (I_f)
- 3 Note down the readings in Table 1 and plot the 'V' curves for synchronous motor under different excitation and load conditions in a separate graph sheet. The same Procedure has to be repeated for loaded condition.

Table 1

Sl. No.	Without Load		With Load	
	Armature Current (I_a)	Field Current (I_f)	Armature Current (I_a)	Field Current (I_f)

Copyright @ NIMI
Not to be Republished

Identify the parts and terminals of MG set

Objectives: At the end of this exercise you shall be able to

- read and interpret the name plate details of the given M.G set
- determine the pairs of terminal of the windings of the DC machine by the test lamp method
- Identify their parts and write their names.

Requirements	
Tools/Instruments	Materials
<ul style="list-style-type: none"> • Insulated combination pliers 200mm - 1 No. • Screw drivers 150 mm - 1 No. • DE Spanner set 5 mm to 20 mm - 1 Set 	<ul style="list-style-type: none"> • PVC insulated cable 3/20 or 660V grade - 5 m • Kit Kat fuse 250V 16A - 1 No. • Pendant lamp holder 250V 6A - 1 No. • SP switch 250V 6A - 1 No. • BC lamp 25/40V 250V - 1 No. • Fuse Wire 5 Amp. - as reqd.
Equipment/Machine	
<ul style="list-style-type: none"> • 3ϕ Sq cage induction motor 5 HP 500V 50 Hz wih $\gamma\Delta$ Starter - 1 No. • DC shunt Generator 5 KW /220V with field regulator - 1 No. 	

PROCEDURE

TASK 1: Identify the parts terminals of motor of a MG set

- 1 Read and Interpret the name plate details of the given 3 phase squirrel cage induction motor and note down as on Table 1.

Table 1

Name plate details

Manufacturer :	Rated Speed :r.p.m.
Model / Number :	Rated frequency :H2
Serial Number :	Type of Connector :Star / Delta.
Rated Voltage :Volts	Insulation Class :
Rated Current :Amps	Protecction Class :
Rated Power :KW / HP.	

- 2 Identify the parts o AC squirrel cage induction motor from the real object or from the exploded view chart. (Fig 1)

- 3 Label the each parts with number and write then name of parts.

Table 2

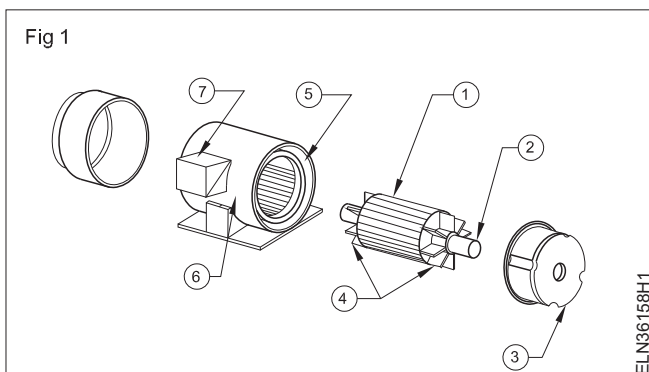

S No.	Label Number	Sq. Cage Induction motor parts.
1		
2		
3		
4		
5		
6		
7		

- Identify the terminals of a 3-phase induction motor with the help of two lamps in series. (Fig 2)
- Observe the condition of the lamp and write the name of terminals.

If the lamps glow bright as shown Fig 2a then the linked ends are similar ends. For example the linked end are U_1 and V_1 .

If the lamps glow dim as shown in Fig 2b, then the linked ends are dis-similar ends. For example the linked end are U_1 and V_2 .

- Get it checked with your instructor.

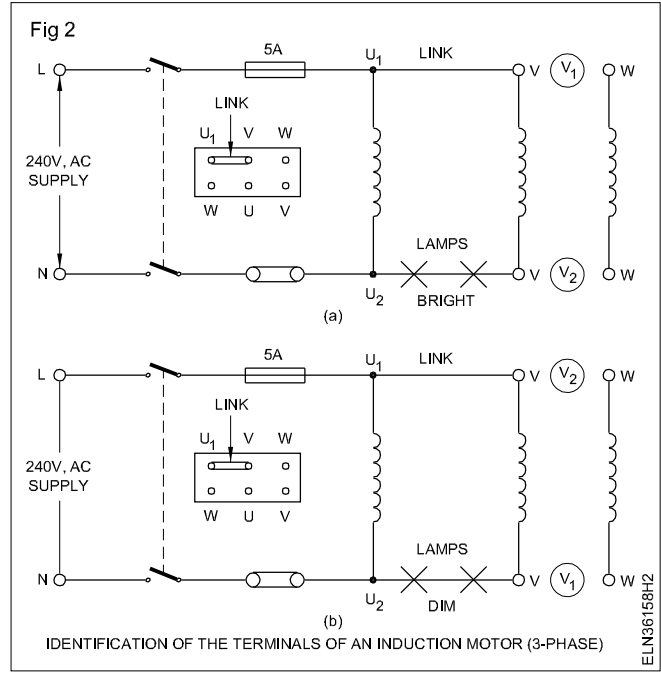

TASK 2 : Identify the terminals of DC generator of the MG set

- Read and interpret the name plate details of the given DC generator and note down in Table 2.

Table 2

Name plate details	
Manufacturer :	Type of generator :
Serial No :	Insulation class :
Rated voltage :	
Rated current :	
Rated power :	

- Identify the terminals of the DC generator and label them as explained in Ex.3.1.115. (Fig 3)
- Write down the terminal name of DC generator.

SI.No.	Label No.	Terminal name
1	1	
2	2	
3	3	
4	4	

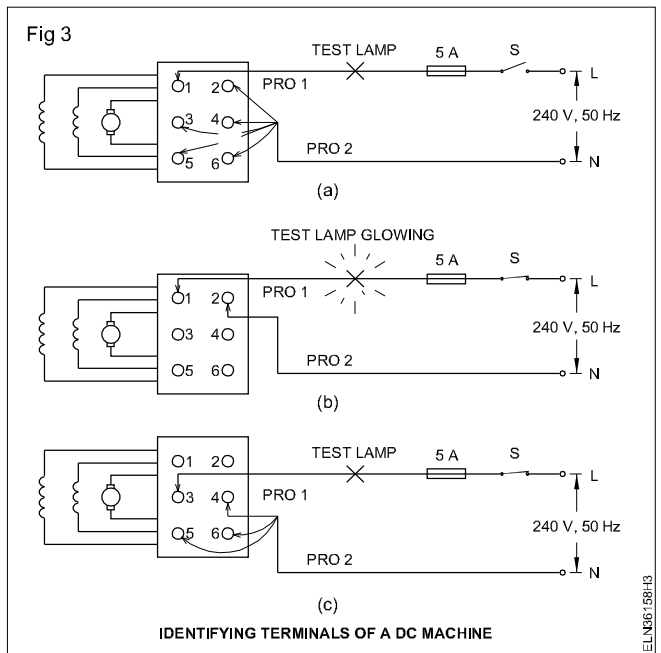

Start, and load a MG set with 3 phase induction motor coupled to DC shunt generator

Objectives: At the end of this exercise you shall be able to

- connect 3-phase motor with the starter
- connect a DC shunt generator, field regulator, ammeter and voltmeter
- start the 3-phase AC motor
- adjust the field regulator and build up DC voltage
- determine combined efficiency of the M.G set.

Requirements

Tools/Instruments

- Electrician Tool kit - 1 Set
- MI Voltmeter 0-500V - 1 No.
- MI Ammeter 0-15A - 1 No.
- MC Ammeter 0 to 2.5A - 1 No.
- MC Ammeter 0 to 15A - 1 No.
- MC Voltmeter 0 to 250 volt - 1 No.
- Power factor meter 500V 15A 0.5 lag to 0.5 lead - 1 No.
- Tachometer multi-range 0-300/1000/3000 rpm - 1 No.

Equipment/Machines

- 3-phase squirrel cage induction motor 5 HP, 500V, 50 Hz with star-delta starter 500V, 16A - 1 No.

- DC shunt generator - 5 KW 220V with field regulator - 1 No.
- Lamp bank of 5 KW - 250 V - 1 No.

Materials

- ICTP switch 16A 500V - 1 No.
- Lamp holder pendent - 2 Nos.
- Lamp 250V, 60 or 100 watts bulb - 2 Nos.
- Stranded PVC insulated wire 7/1.5 aluminium cable - 4 m
- D.P.S.T. Switch 16A, 250V - 1 No.
- PVC insulated connecting cable - as reqd.
- ICDP switch 16A 250V - 1 No.
- Graph sheet - as reqd.

PROCEDURE

TASK 1 : Start run and load a MG set

- 1 Connect the AC motor and generator. (Fig 1)

Keep the field regulator at a position to include zero resistance in the circuit. Keep switch S_1 and S_2 in 'off' position.

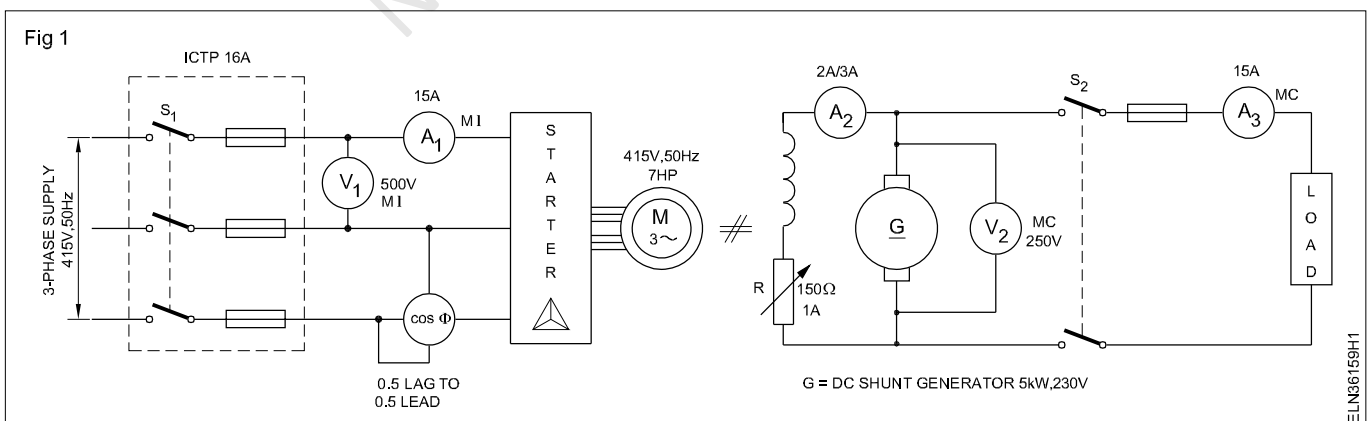

- 2 Start the AC motor. Measure the speed using a tachometer.
- 3 Build up the DC generator terminal voltage to its rated value and observe the voltmeter (V_2) reading.
- 4 Switch 'ON' the load switch S_2 .
- 5 Increase the load gradually by switching 'on' the lamps in steps up to the rated capacity of MG set.

- 6 Measure the speed of the generator for each load condition and record in Table 1.
- 7 Record input current, voltage and power factor in Table 1. Read and record the load current and terminal voltage of generator in Table 1.
- 8 Switch 'OFF' the load in steps and open the load switch S_2 .
- 9 Calculate the input power.

- 10 Calculate the output power.

- 11 Calculate the total loss and the efficiency at full load.

- 12 Stop the prime mover of the M.G. set and isolate supply.

Conclusion

Observe from the readings in Table that the terminal voltage drops with increase in load. State your reasons.

Table 1

OUTPUT			INPUT		
Load current (I)	Terminal voltage (V)	Speed in r.p.m	Line current (I_L)	Line voltage (V_L)	Power factor

Project work

Objectives: The Trainees/Participants shall be able to

- select a project work of their choice
- prepare the list of materials required and collect them
- list out the tools required
- prepare a brief note on the project
- complete the project and submit the project report with all the details.

Note: Instructor has to explain in detail regarding the project works to be carried out in the section. The trainees may be divided in groups according to the strength available in section and give all details how to prepare and finish the work with complete workmanship and accuracy.

- Step to start and follow the project work
- Motivate the group by emphasising the technical work involved and its future influences.
- Divide the work equally and make sure in yoke participating with full interest.
- Start the project work, test it stage by stage and complete it.
- Test the completed project job for its functionality and its utility.
- Prepare a project report containing its technical parameters, specification, material requirement and its cost, operational procedure, maintenance, utility and marketing etc.
- Indicate the scope of future expansion, easy conversion to other project for advanced version in the report.

- Get it checked with your instructor.
- The project should complete with all operational instructions and carry necessary procedure with switches, controls, labels, symbols etc.
- Safety devices has to be placed according to the project and its functions.
- Maintenance and repair instructions should be indicated clearly.

Note: Instructor has to evaluate the project work with all records and reports. Marks to be awarded for the project working, accuracy, workmanship, safety features and its work performance related to the viva questions.

Project work

- 1 Phase sequence checker for 3 phase supply
- 2 Induction motor protection system
- 3 Motor starters with protection
- 4 Solar/wind power generation.

